

Installation and Setup Guide
020-102534-02

CP2308

CHRISTIE®

NOTICES

COPYRIGHT AND TRADEMARKS

Copyright © 2018 Christie Digital Systems USA Inc. All rights reserved.

All brand names and product names are trademarks, registered trademarks or trade names of their respective holders.

GENERAL

Every effort has been made to ensure accuracy, however in some cases changes in the products or availability could occur which may not be reflected in this document. Christie reserves the right to make changes to specifications at any time without notice. Performance specifications are typical, but may vary depending on conditions beyond Christie's control such as maintenance of the product in proper working conditions. Performance specifications are based on information available at the time of printing. Christie makes no warranty of any kind with regard to this material, including, but not limited to, implied warranties of fitness for a particular purpose. Christie will not be liable for errors contained herein or for incidental or consequential damages in connection with the performance or use of this material. Canadian manufacturing facility is ISO 9001 and 14001 certified.

WARRANTY

Products are warranted under Christie's standard limited warranty, the complete details of which are available by contacting your Christie dealer or Christie. In addition to the other limitations that may be specified in Christie's standard limited warranty and, to the extent relevant or applicable to your product, the warranty does not cover:

- a. Problems or damage occurring during shipment, in either direction.
- b. Projector lamps (See Christie's separate lamp program policy).
- c. Problems or damage caused by use of a projector lamp beyond the recommended lamp life, or use of a lamp other than a Christie lamp supplied by Christie or an authorized distributor of Christie lamps.
- d. Problems or damage caused by combination of a product with non-Christie equipment, such as distribution systems, cameras, DVD players, etc., or use of a product with any non-Christie interface device.
- e. Problems or damage caused by the use of any lamp, replacement part or component purchased or obtained from an unauthorized distributor of Christie lamps, replacement parts or components including, without limitation, any distributor offering Christie lamps, replacement parts or components through the internet (confirmation of authorized distributors may be obtained from Christie).
- f. Problems or damage caused by misuse, improper power source, accident, fire, flood, lightning, earthquake or other natural disaster.
- g. Problems or damage caused by improper installation/alignment, or by equipment modification, if by other than Christie service personnel or a Christie authorized repair service provider.
- h. Problems or damage caused by use of a product on a motion platform or other movable device where such product has not been designed, modified or approved by Christie for such use.
- i. Problems or damage caused by use of a projector in the presence of an oil-based fog machine or laser-based lighting that is unrelated to the projector.
- j. For LCD projectors, the warranty period specified in the warranty applies only where the LCD projector is in "normal use" which means the LCD projector is not used more than 8 hours a day, 5 days a week.
- k. Except where the product is designed for outdoor use, problems or damage caused by use of the product outdoors unless such product is protected from precipitation or other adverse weather or environmental conditions and the ambient temperature is within the recommended ambient temperature set forth in the specifications for such product.
- l. Defects caused by normal wear and tear or otherwise due to normal aging of a product.

The warranty does not apply to any product where the serial number has been removed or obliterated. The warranty also does not apply to any product sold by a reseller to an end user outside of the country where the reseller is located unless (i) Christie has an office in the country where the end user is located or (ii) the required international warranty fee has been paid.

The warranty does not obligate Christie to provide any on site warranty service at the product site location.

PREVENTATIVE MAINTENANCE

Preventative maintenance is an important part of the continued and proper operation of your product. Failure to perform maintenance as required, and in accordance with the maintenance schedule specified by Christie, will void the warranty. For preventative maintenance schedules, refer to www.christiedigital.com.

REGULATORY

The product has been tested and found to comply with the limits for a Class A digital device, pursuant to Part 15 of the FCC Rules. These limits are designed to provide reasonable protection against harmful interference when the product is operated in a commercial environment. The product generates, uses, and can radiate radio frequency energy and, if not installed and used in accordance with the instruction manual, may cause harmful interference to radio communications. Operation of the product in a residential area is likely to cause harmful interference in which case the user will be required to correct the interference at the user's own expense.

CAN ICES-3 (A) / NMB-3 (A)

이 기기는 업무용(A급)으로 전자파적합등록을 한 기기이오니 판매자 또는 사용자는 이점을 주의하시기 바라며, 가정 외의 지역에서 사용하는 것을 목적으로 합니다.

ENVIRONMENTAL

The product is designed and manufactured with high-quality materials and components that can be recycled and reused. This symbol  means that electrical and electronic equipment, at their end-of-life, should be disposed of separately from regular waste. Please dispose of the product appropriately and according to local regulations. In the European Union, there are separate collection systems for used electrical and electronic products. Please help us to conserve the environment we live in!

Content

Safety precautions.	5
Introduction.	7
Projector components - front.	7
Projector components - rear.	8
List of components.	8
Product documentation.	8
Related documentation.	9
Installation and setup.	10
Lifting and positioning the projector.	10
Light intensity hazard distance.	10
Adjusting tilt and leveling the projector.	12
Stacking projectors.	12
Installing the touch panel.	15
Installing the lens.	16
Installing the lamp.	18
Connecting power.	20
Turning the projector on or off.	21
Logging on to the projector.	22
Activating marriage.	22
Connecting devices to the projector and establishing communication.	23
Projector head connections and status LEDs.	23
Connecting the projector to a computer.	24
Connecting devices to the 3D sync terminal.	25
Adjusting the image.	26
Activating the Intelligent Lens System.	26
Calibrating the ILS automatically.	26
Correcting vignetting.	26
Correcting keystone effect.	26
Adjusting vertical boresight.	27
Adjusting horizontal boresight.	28
Adjusting digital micromirror device convergence.	30

Adjusting the fold mirror. 30

Calibrating the color. 31

CP2308 Specifications. 32

Physical specifications. 32

Power specifications. 32

Environmental specifications. 33

Display specifications. 33

Control signal compatibility. 34

Touch panel specifications. 36

Lamp specifications. 36

Accessories. 37

Regulatory. 38

 Safety. 38

 Electro-magnetic compatibility. 38

 Environmental. 39

Safety precautions

Observe these important safety rules to avoid personal injury or damage to the projector.

This projector must be operated in an environment that meets the operating range, as listed in the *projector specifications* (on page 32).

General precautions



Warning! If not avoided, the following could result in death or serious injury.

- TRIP OR FIRE HAZARD! Position all cables where they cannot contact hot surfaces, be pulled, be tripped over, or damaged by persons walking on or objects rolling over the cables.
- This product must be installed within a restricted access location not accessible by the general public.
- Only personnel who are trained on the precautions for the restricted access location can be granted entry to the area.
- ELECTRICAL and BURN HAZARD! Use caution when accessing internal components.
- High leakage current present when connected to IT power systems.
- Possible hazardous optical radiation emitted from this product. (Risk group 3 under IEC 62471)
- For protection from ultraviolet radiation, keep all product housings intact during operation.
- UV EXPOSURE! Protective UV safety glasses with side shields and Christie approved protective safety clothing must be worn when performing optical adjustments or servicing the product.
- FIRE AND SHOCK HAZARD! Use only the attachments, accessories, tools, and replacement parts specified by Christie.
- A minimum of four people or appropriately rated lift equipment is required to safely lift, install, or move the product.

Power



Warning! If not avoided, the following could result in death or serious injury.

- SHOCK HAZARD! Only use the AC power cord provided with the product or recommended by Christie.
- FIRE AND SHOCK HAZARD! Do not attempt operation unless the power cord, power socket, and power plug meet the appropriate local rating standards.
- SHOCK HAZARD! Do not attempt operation if the AC supply is not within the specified voltage and current, as specified on the license label.
- SHOCK HAZARD! The AC power cord must be inserted into an outlet with grounding.
- SHOCK HAZARD! Disconnect the product from AC before installing, moving, servicing, cleaning, removing components, or opening any enclosure.
- FIRE HAZARD! Do not use a power cord, harness, or cable that appears damaged.



Caution! If not avoided, the following could result in minor or moderate injury.

- Only Christie qualified technicians are permitted to open product enclosures.
- Install the product near an easily accessible AC receptacle.

Lamp



Warning! If not avoided, the following could result in death or serious injury.

- EXPLOSION HAZARD! Lamps and bare bulbs, even when packaged, may explode if dropped or mishandled.
- EXPLOSION HAZARD! Always wear manufacturer approved protective safety clothing (gloves, jacket, face shield) whenever the lamp door is open or when handling the lamp. Any local or federal specifications take precedence over Christie's protective clothing recommendations.
- Do not open the lamp door while the lamp is on.
- EXPLOSION HAZARD! Allow sufficient time for the lamp to cool down before powering down the product, disconnecting it from AC, and opening the lamp door.
- Do not look directly into the lens when the light source is on. The extremely high brightness can cause permanent eye damage.
- FIRE HAZARD! Keep hands, clothes, and all combustible material away from the concentrated light beam of the projector.

Introduction

This manual is intended for professionally trained operators of Christie high-brightness CP2308 projection systems.

Only Christie qualified technicians who are knowledgeable about the hazards associated with high-voltage, ultraviolet exposure, and the high temperatures generated by the projector are authorized to assemble, install, and service the projector.

For complete production documentation and technical support, go to www.christiedigital.com.

Projector components - front

Learn about the components on the front of the projector.

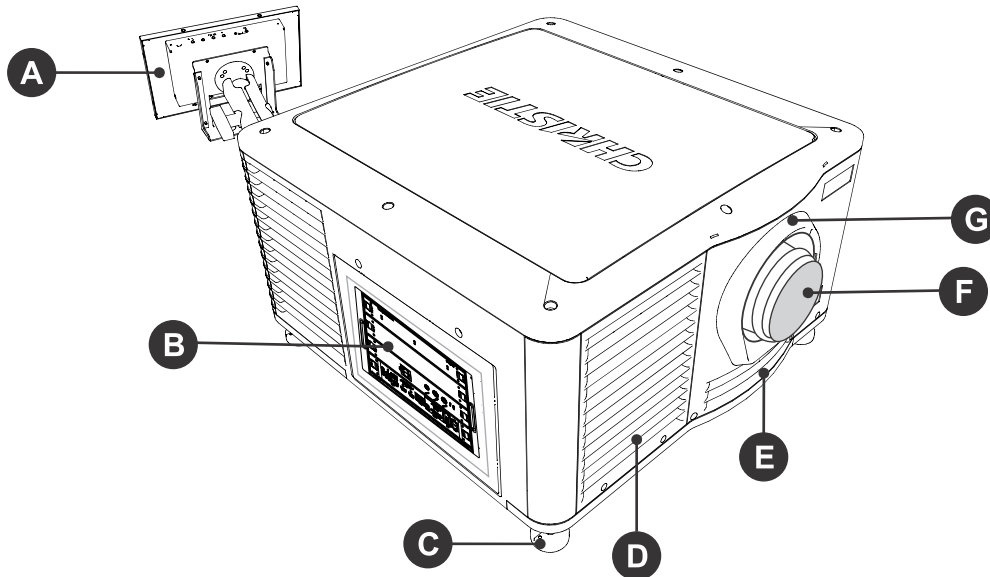

A	Touch panel A touch-sensitive screen used to control the projector.	E	Air filter cover and air filter Located behind the air filter cover is a replaceable air filter.
B	Communications panel External devices are connected here.	F	Projector lens A list of available lenses is available in the projector specifications.
C	Adjustable feet Turn the adjustable feet to increase or decrease the projector height.	G	Lens surround
D	Air Filter	H	Top lid

Projector components - rear

Learn about the components on the back of the projector.

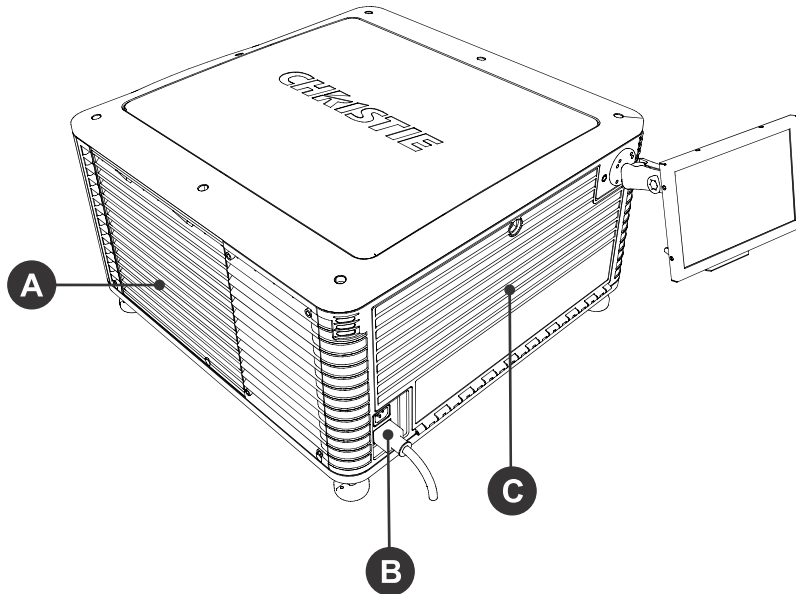

A	Service access door
B	Power cord and AC receptacle
C	Light source access door

List of components

Verify all components were received with the projector.

- Power cord
- Touch panel
- Convergence tool
- Stacking kit, including stacking cups, locking brackets, and required screws

Product documentation

For installation, setup, and user information, see the product documentation available on the Christie Digital Systems USA Inc. website. Read all instructions before using or servicing this product.

1. Access the documentation from the Christie website:
 - Go to this URL: <http://bit.ly/2wOIqIS> or <https://www.christiedigital.com/en-us/cinema/cinema-products/digital-cinema-projectors/christie-cp2308>
 - Scan the QR code using a QR code reader app on a smartphone or tablet.

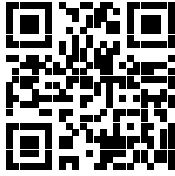

2. On the product page, switch to the **Downloads** tab.

Related documentation

Additional information on this product is available in the following documents.

- *CP2308 Product Safety Guide (P/N: 020-102536-XX)*
- *CP2308 User Guide (P/N: 020-102535-XX)*
- *CP2308 Serial Commands Guide (P/N: 020-102485-XX)*

Installation and setup

Learn how to install, connect, and optimize the projector.
This section provides detailed information on projector setup.

Lifting and positioning the projector

Safely lift and position the projector in the location where it will be used.



Warning! If not avoided, the following could result in death or serious injury.

- A minimum of four people or appropriately rated lift equipment is required to safely lift, install, or move the product.
- Do not install or operate the projector in any position that does not meet the stated product specifications for alignment and orientation.



Before lifting and positioning the projector, refer to *the light intensity hazard distance clearance requirements* (on page 10).

1. Position each person at the corners of the projector.
2. Lift up the projector and move it to the location where it will be used.
3. Position the projector so it is centered and parallel with the theater screen. If space is limited, aim the projector slightly off-center and use lens offset to center the image on the screen.

Light intensity hazard distance

This projector has been classified as Risk Group 3 as per the IEC62471 standard due to possible hazardous optical and thermal radiation being emitted.



Warning! If not avoided, the following could result in serious injury.

- PERMANENT/TEMPORARY BLINDNESS HAZARD! No direct exposure to the beam must be permitted. .
- PERMANENT/TEMPORARY BLINDNESS HAZARD! Operators must control access to the beam within the hazard distance or install the product at the height that prevents exposure of spectators' eyes within the hazard distance. The hazard zone must be no lower than 2.5 meters (US installations) or 2.0 meters (global installations) above any surface upon which any persons are permitted to stand and the horizontal clearance to the hazard zone must be a minimum 1.0 meters.
- EXTREME BRIGHTNESS! Do not place reflective objects in the product light path.

The following diagram and table show the zones for ocular and skin hazard distances:

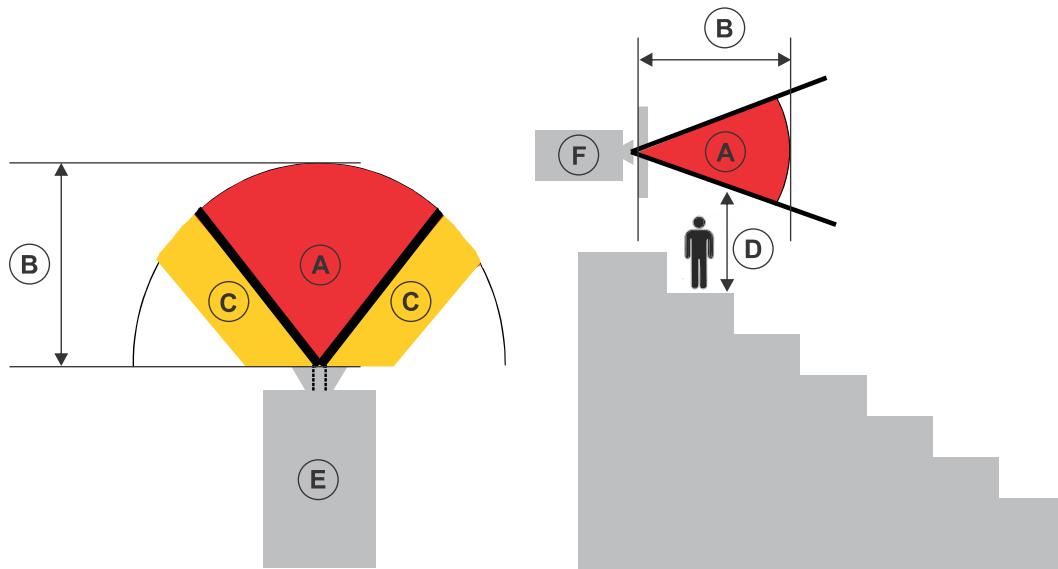

- A—Hazard zone. The region of space where the projection light from the projector is above emission limits for Risk Group 2. The light intensity may cause eye damage after a momentary or brief exposure (before a person can avert his or her eyes away from the light source). The light may cause skin burns to occur.
- B—Hazard distance. Operators must control access to the beam within the hazard distance or install the product preventing potential exposure of the spectators' eyes from being in the hazard distance.
- C—No access zone. Horizontal clearance of the no access zone must be a minimum of 1.0 meters.
- D—Vertical distance to hazard zone. The hazard zone must be no lower than 2.5 meters (US installations) or 2.0 meters (global installations) above any surface upon which any persons are permitted to stand.
- E—Represents the top view of the projector.
- F—Represents the side view of the projector.

Projection lens	Part number	Hazard distance (m)
1.2-1.72:1, 0.69" DLPCine zoom lens	108-494108-XX	1.1
1.33-2.1:1, 0.69" DLPCine zoom lens	108-495109-XX	1.3
1.62-2.7:1, 0.69" DLPCine zoom lens	108-496100-XX	1.6
2.09-3.9:1, 0.69" DLPCine zoom lens	108-497101-XX	2.4

Adjusting tilt and leveling the projector

To ensure optimum performance, install the projector so it is centered and parallel with the screen. To compensate for tilt or offset, you can adjust the projector feet and the lens mount position.



The front-to-back tilt of the projector must not exceed 15°.

1. To adjust the height of the projector, loosen the lock nut on the adjustable feet on the bottom of the projector.

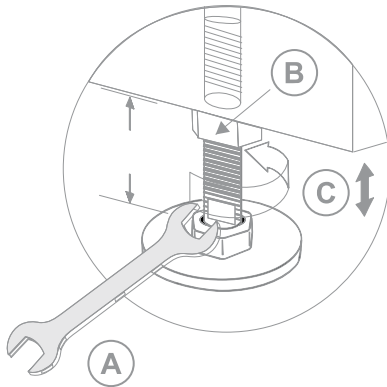

A	19 mm (0.75 in.) wrench
B	Lock
C	Turn to adjust height

2. Extend or retract the feet.
3. When the adjustment is correct, tighten the lock nut.

Stacking projectors

To stack CP2308 projectors, use the stacking kit provided.

The stacking kit includes these parts:

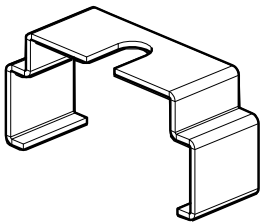
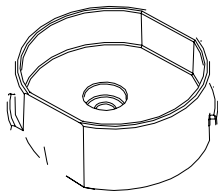
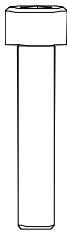
		
Locking bracket (quantity 4)	Stacking cup (quantity 4)	M6 screw (quantity 4)

When stacking projectors, the optical axis of the projectors must be parallel to one another. The maximum tilt for stacked projectors is 13 degrees. When you install the stacked projectors in a rack stand or on a pedestal, the rack stand or the pedestal must remain horizontal. If you require tilt to align your images, you must tilt the projectors and not the rack stand or pedestal.

1. On the bottom projector, remove the four corner screws securing the top lid.

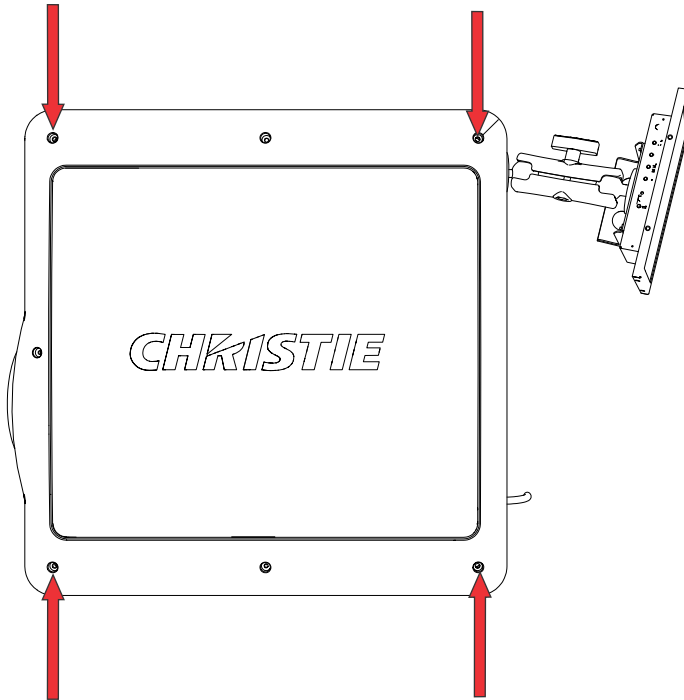

2. Position a single stacking cup (011-104349-XX) over one of the empty screw holes so the higher side of the cup faces outward and aligns with the projector skin.

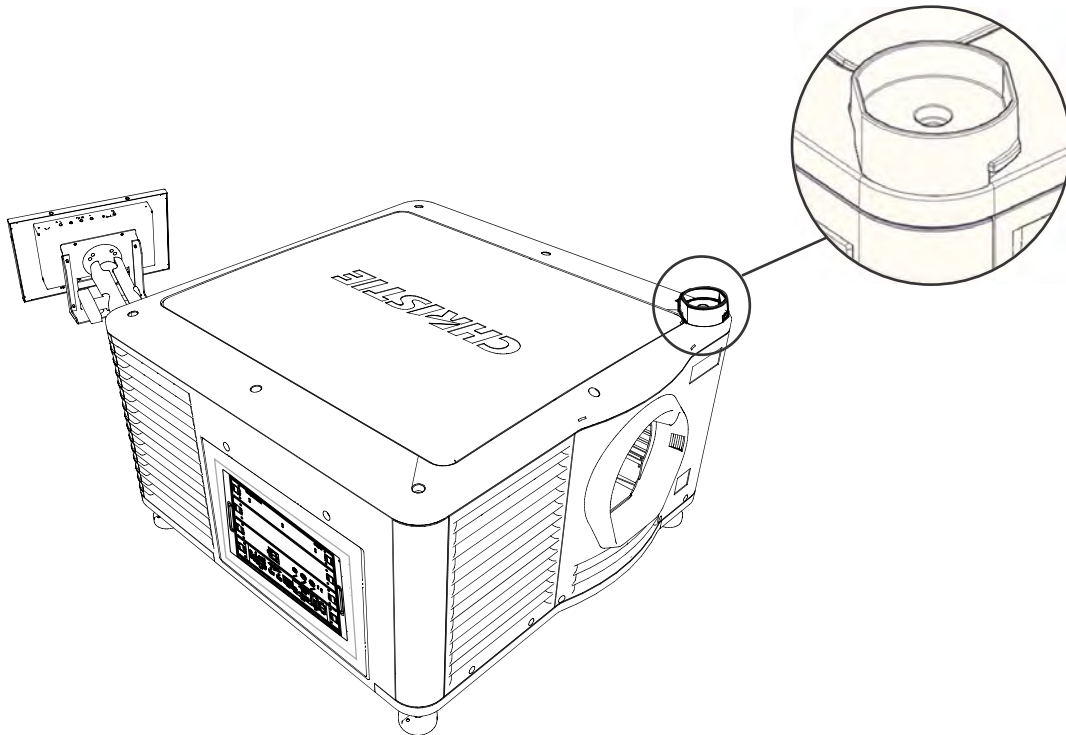

3. Insert an M6 screw (012-101132-XX) through the stacking cup mounting hole and into the projector.

4. With a torque wrench, tighten the M6 screw to 15 in-lb.
5. Repeat steps 3 to 5 to install the three remaining stacking cups.
6. With the assistance of another person, lift the second projector and position it on top of the bottom projector so each of its feet fit into a stacking cup. The lenses of both projectors must face the same direction and the optical axis of both projector lenses must be parallel (A) and align vertically (B).

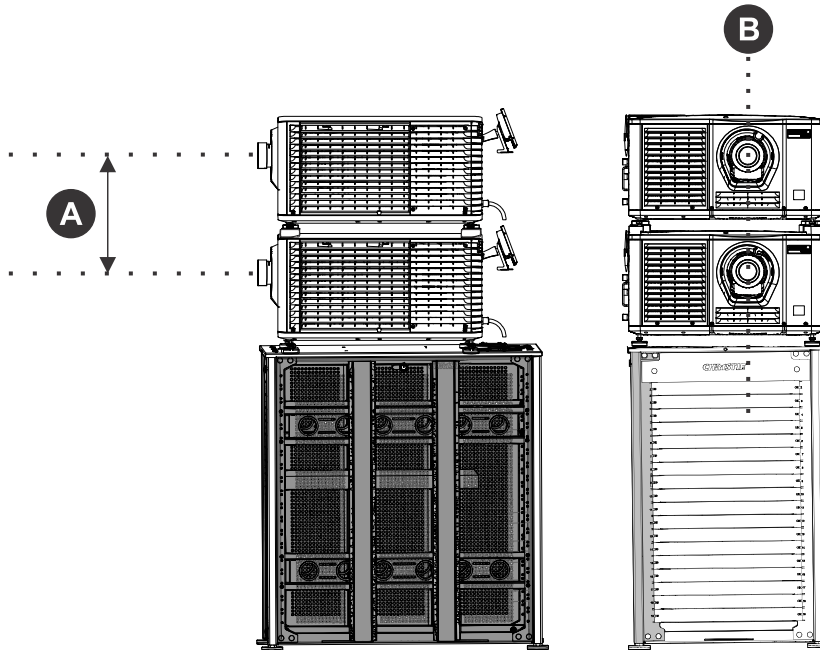

7. Install both projectors.
 - a) *Install the touch panel* (on page 15).
 - b) *Install the lens* (on page 16).
 - c) *Install the lamp* (on page 18).
 - d) *Connect devices to the projector* (on page 23).
 - e) *Connect power* (on page 20).
 - f) Adjust the bottom projector image to fit the screen. For more information, see the *CP2308 User Manual*.
 - g) Align the top projector image to the bottom projector image. For more information, see the *CP2308 User Manual*.
8. When both projectors are installed and aligned correctly, install the locking brackets on the feet of the top projector.
 - a) Slide the locking bracket (011-104470-XX) over the flat sides of the stacking cup, so the notch in the locking bracket fits around the projector leg and above projector foot nut.
 - b) Turn the locking bracket so the flanges of the locking bracket fit tightly below the stacking cup tabs.
 - c) Repeat steps a and b to install the three remaining locking brackets

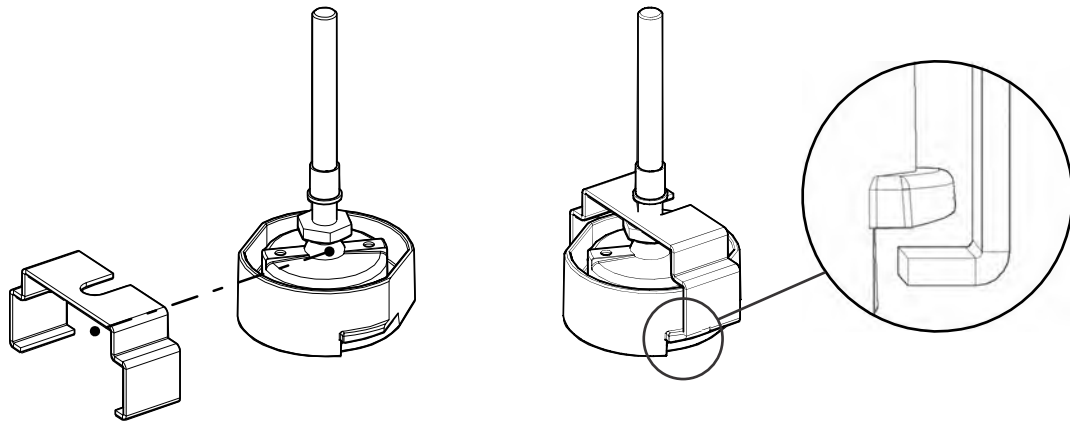

Installing the touch panel

The touch panel controls projector functions and provides quick access to projector information.

The touch panel can be mounted on the rear panel or the electronics side of the projector.

1. Remove the touch panel and the mounting arm from their packaging.
2. Attach one end of the touch panel mounting arm over the ball joint on the rear of the touch panel.

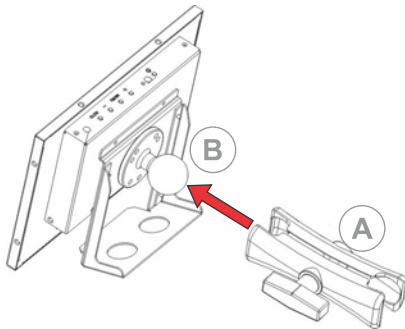

A	Mounting arm
B	Ball joint

3. While supporting the touch panel, fit the other end of the touch panel mounting arm over the ball joint on the rear panel or electronics side of the projector.

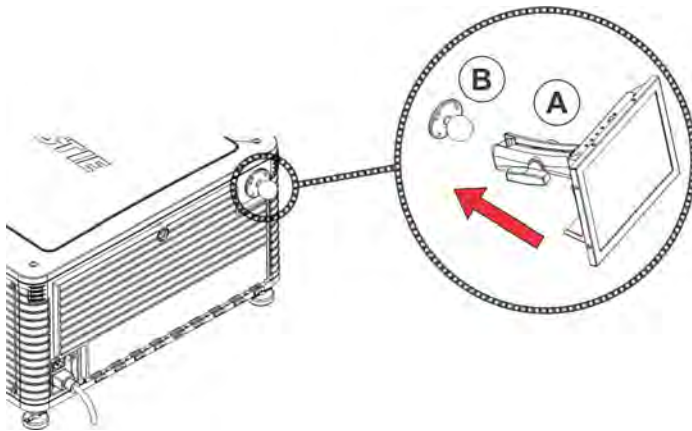

A	Mounting arm
B	Ball joint

4. Tighten the mounting arm until it fits tightly on the ball joint.

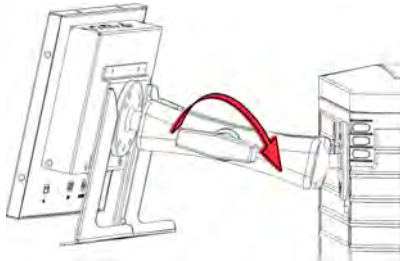

5. Connect the touch panel harness to the touch panel:
 - a) Connect one end of the USB cable to the USB port on the rear of the touch panel.
 - b) Connect one end of the touch panel power cable to the **DC IN 12V** port on the rear of the touch panel.
 - c) Connect one end of the VGA connector to the **VGA** port on the rear of the touch panel.
6. Connect the touch panel harness to the projector:
 - a) Connect the other end of the USB cable to a USB port on the projector communications panel.
 - b) Connect the other end of the touch panel power cable to the Screen Power port on the projector communications panel.
 - c) Connect the other end of the VGA connector to the VGA Out port on the projector communications panel.
7. To turn the touch panel on, press the power button on the top of the panel.
If the projector is not connected to AC power, you cannot turn the touch panel on.

Installing the lens

The lens seals the projection head, preventing contaminants from entering the main electronics area. Before installing the lens, ensure that you turn off and unplug the projector.

Do not operate the projector without a lens installed. Install a lens plug when you install or transport the projector.

1. Remove the lens surround.
2. Turn the lens clamp on the front of the projector to the open position with a hex key.

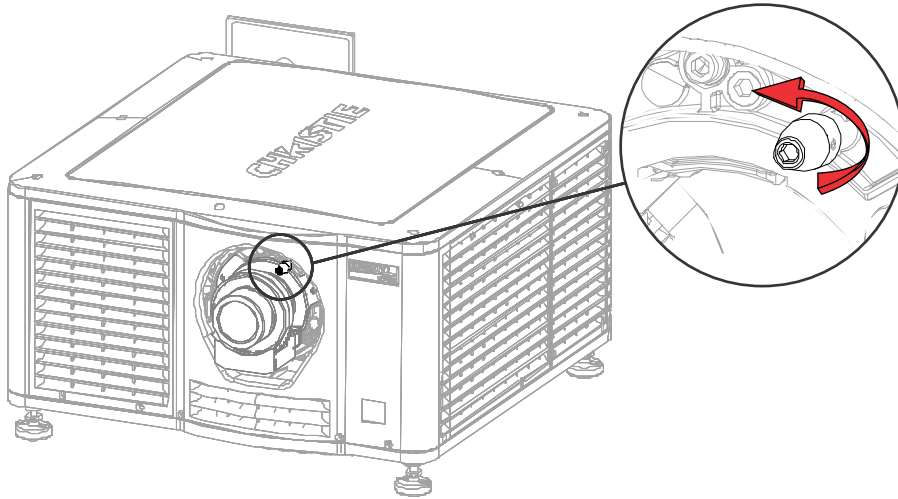

3. Position the lens so the lens retaining ring mounts align with the lens mount.
4. Remove the lens caps from the front and rear of the lens.



Lens caps must be removed or they can melt and damage the lens.

5. Insert the lens straight into the lens mount opening without turning. Magnets inside the lens mount help position the lens.
6. Insert and tighten the two lens mount hex screws shipped separately with the projector.

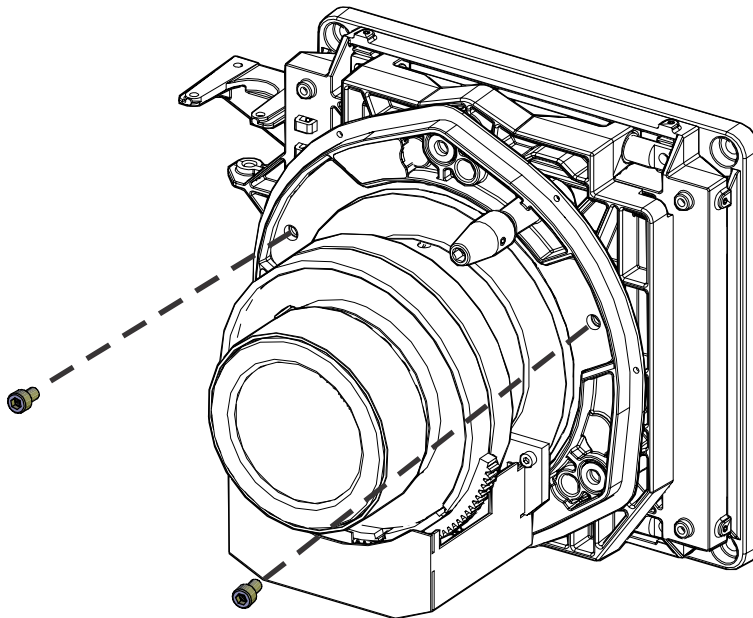

7. Lock the lens assembly in place with a hex key.

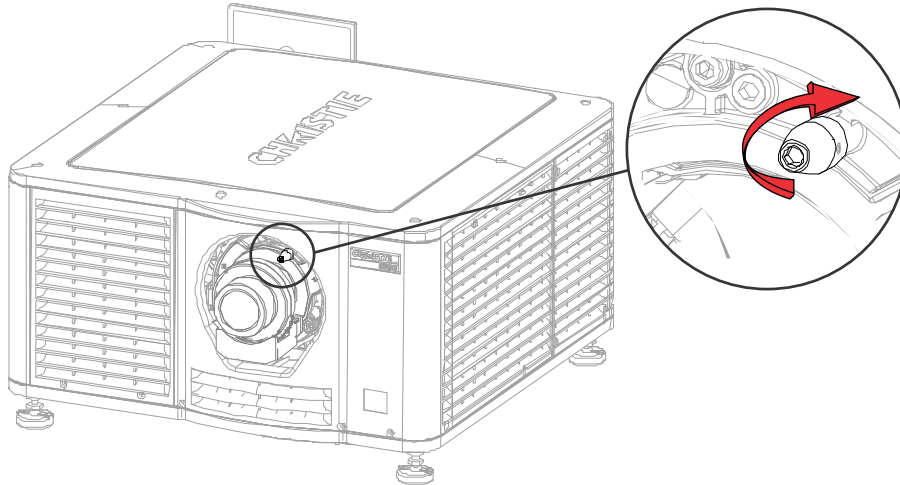

8. Replace the lens surround.

Installing the lamp

Complete the following procedure to install the lamp.



Warning! If not avoided, the following could result in death or serious injury.

- This procedure must be performed by Christie qualified technicians.
- EXPLOSION HAZARD! Always wear manufacturer approved protective safety clothing (gloves, jacket, face shield) whenever the lamp door is open or when handling the lamp. Any local or federal specifications take precedence over Christie's protective clothing recommendations.
- Do not open the lamp door while the lamp is on.
- EXPLOSION HAZARD! Allow sufficient time for the lamp to cool down before powering down the product, disconnecting it from AC, and opening the lamp door.
- EXPLOSION HAZARD! Do not stress the glass of a lamp or bare bulb in any way.
- EXPLOSION HAZARD! Lamps and bare bulbs, even when packaged, may explode if dropped or mishandled.



Caution! If not avoided, the following could result in minor or moderate injury.

- Improper installation of the lamp can damage the projector.
 - Incorrect lamp power supply and igniter connections can damage the product.
1. If the projector is operating, turn it off and allow it to cool a minimum of 15 minutes.
 2. Turn the breaker switch for the projector off.
 3. Disconnect the projector from AC power.
 4. Disconnect the touch panel communication cable from the rear of the projector.
 5. Remove the touch panel from the rear of the projector.
 6. Put on your protective clothing, face shield, and gloves.
 7. Insert the key in the lamp door lock, turn the key, and then open the lamp door.
 8. Loosen the two thumbscrews and open the firewall door.

9. Loosen the two thumbscrews and open the lamp access door.
10. Loosen the cathode clamp with the 5 mm hex key attached to the lamp door.

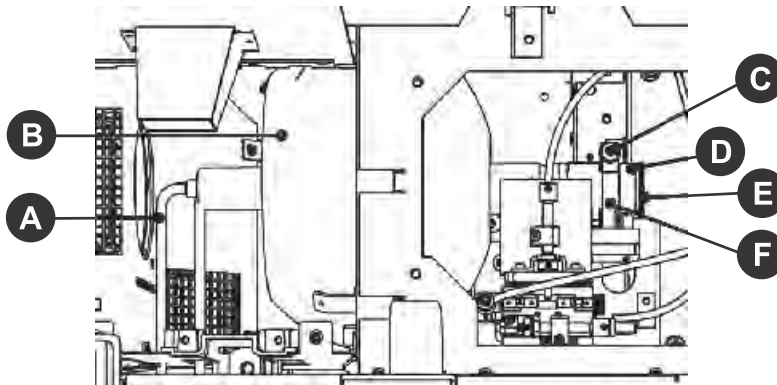

A	Anode wire
B	Reflector
C	Cathode clamp
D	Extension nut (for CDXL-14 and CDXL-16)
E	Cathode nut
F	Cathode clamp

11. For CDXL-14 or CDXL-16 lamps:



Warning! If not avoided, the following could result in death or serious injury.

- EXPLOSION HAZARD! Handle a lamp by the cathode and anode end shafts only. Do not handle the lamp by the glass.
 - EXPLOSION HAZARD! Do not over-tighten the lamp.
 - EXPLOSION HAZARD! Do not stress the glass of a lamp or bare bulb in any way.
- a) Install the lamp extension nut on the cathode clamp. To provide access to the locking screw on the extension nut, rotate the extension nut until the locking screw faces upward toward the projector lid.
The extension nut is only used with CDXL-14 and CDXL-16 lamps.
 - b) Thread on and hand-tighten the cathode nut. Ensure the smooth portion of the nut is against the cathode clamp.
 - c) Hold the anode end of the new lamp in your left hand and angle it up through the hole in the back of the reflector assembly. Insert your right index and middle finger through the back of the reflector and thread the cathode end of the lamp into the extension nut.
Check all leads. When threading the lamp into the extension nut, make sure the anode (+) wire does not touch any projector metal, such as the reflector or firewall.
 - d) Tighten the extension nut screw.
 - e) Move to step 13.
12. For CDXL-19SC or CDXL-21S1 lamps:
 - a) Hold the anode end of the new lamp in your left hand and angle it up through the hole in the back of the reflector assembly.

- b) Insert your right index and middle finger through the back of the reflector and guide the lamp onto the cathode clamp.
Be careful not to hit the lamp against the reflector.
 - c) Thread on and hand-tighten the cathode nut. Ensure the smooth portion of the nut is against the cathode clamp.
 - d) Tighten the cathode screw (D) with a hex key.
13. Align the ring terminal on the anode wire with the mounting position ensuring the crimped side of the wire is facing out.
 14. Tighten the anode screw.
 15. Route anode lead away from nearby metal surfaces.
 16. Close the lamp access door and tighten the two thumbscrews.
 17. Close the fire wall door and tighten the two thumbscrews.
 18. Close and lock the rear access door. Ensure the hex key is placed back into its holder before closing the rear access door.

Connecting power

Connect the projector to the power source.



Warning! If not avoided, the following could result in death or serious injury.

- SHOCK HAZARD! A dedicated, protected ground or earth wire must be installed on the product by Christie qualified technicians or electricians before it can be connected to power.
- SHOCK HAZARD! Only use the AC power cord provided with the product or recommended by Christie.
- FIRE AND SHOCK HAZARD! Do not attempt operation unless the power cord, power socket, and power plug meet the appropriate local rating standards.
- SHOCK HAZARD! The AC power cord must be inserted into an outlet with grounding.
- SHOCK HAZARD! Do not attempt operation if the AC supply is not within the specified voltage and current, as specified on the license label.
- SHOCK HAZARD! Disconnect the product from AC before installing, moving, servicing, cleaning, removing components, or opening any enclosure.
- The appliance coupler and main power supply plug must be easily accessible for disconnecting the product from the power source.



Caution! If not avoided, the following could result in minor or moderate injury.

- Only Christie qualified technicians are permitted to open product enclosures.
- Install the product near an easily accessible AC receptacle.
- For products containing surge suppressors, you must adhere to the installation and power requirements.

Installation and Power Requirements

The protected earth wire must be green/yellow 12 AWG minimum.

You must use a 20A branch circuit breaker for Input A.

1. If the projector is operating, turn it off and disconnect it from AC power.

- Loosen the threaded bolt on the ground lug on the AC receptacle on the rear of the projector.

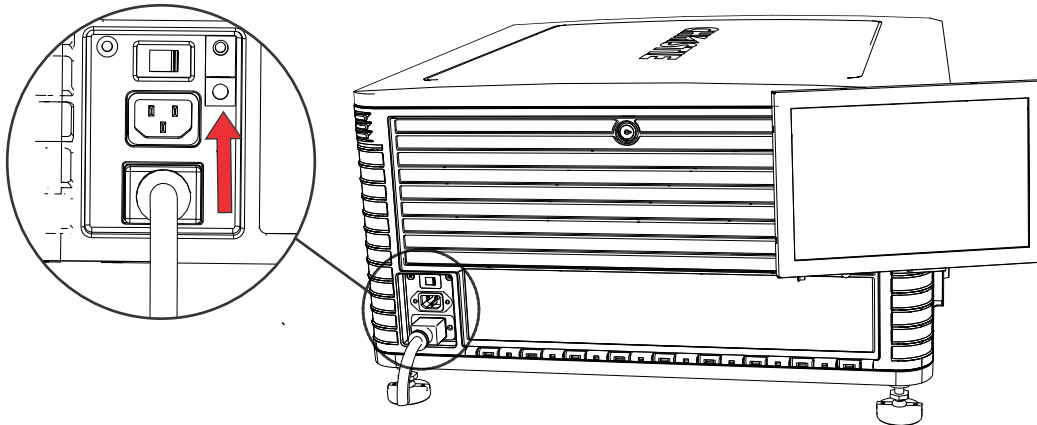

- Remove 15 mm of insulated covering from both ends of the protected earth wire.
- Insert a bare end of the protected earth wire into the hole on the top of the ground lug so it is beneath the threaded bolt.
- Tighten the threaded bolt to 50 in-lb.
- Connect the other bare end of the protected earth wire to the building ground.
- Connect one end of the projector power cord to the AC receptacle on the lower-left rear corner of the projector and then connect the other end of the power cord to an AC receptacle.
- If you are using an Uninterrupted Power Supply (UPS) to power the main electronics, move the AC switch to A + B and connect the power cord provided with the UPS to the B outlet.

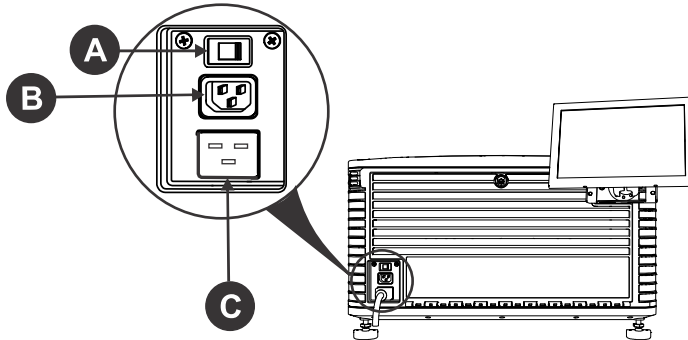

A	AC switch
B	100-240 V secondary inlet
C	200-240 V main inlet

Turning the projector on or off

Turn the projector on to display content, or turn the projector off to conserve energy.

- In the right toolbar, tap and hold **Power**. 

Logging on to the projector

Log on to the projector to access projector menus.

1. Tap **Login**.
2. In the User list, select a user name.
3. Enter your password.
4. Tap **Login**.

Activating marriage

You must complete marriage to display content and to comply with the Digital Cinema Initiatives (DCI) specification.

You cannot complete marriage remotely.

1. In the left navigation menu, tap **Service Setup > Marriage Setup**.
2. Tap **Start** and complete the Marriage Setup wizard.
3. Tap **Finish**.

Connecting devices to the projector and establishing communication

To display content, you must connect a device that is capable of storing or playing content to the projector.

Projector head connections and status LEDs

Understand the inputs on the projector.

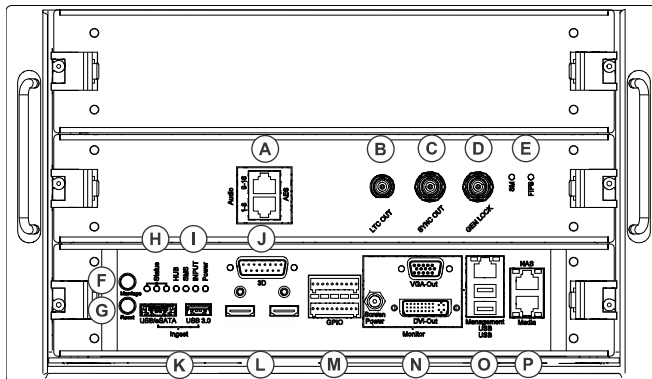

A	AES3 port for digital audio output.
B	Linear Time Code (LTC) output.
C	Output for multi-projector playback.
D	Input for multi-projector playback (Christie IMB to Christie IMB only).
E	LED status indicators: <ul style="list-style-type: none"> • SM —The LED flashes green when the security manager (SM) is running correctly. • FIPS—The LED is green when the FIPS (Federal Information Processing Standards Publications) security status is operating correctly. If the LED is red, an error has occurred. Restart the Christie IMB. If the LED remains red, return the Christie IMB to Christie Digital Systems USA Inc.

F	Indicates marriage status. In full power mode, a green LED indicates that the projector is properly married and encrypted content can be displayed. A red LED indicates marriage is broken and encrypted content cannot be displayed.
G	Resets the projector electronics. After restarting, the projector returns to its previous power mode.
H	LED status indicators: <ul style="list-style-type: none"> • Standby mode—The green LED flashes once per second and the yellow and red LEDs are off. • Warm up—The green LED flashes three times per second and the yellow and red LEDs are off. • Power on, lamp on or off—The green LED is solid green and the yellow and red LEDs are off. • Cool down—The green and yellow LEDs flash three times per second and the red LED is off. • Notification—The green LED is solid green, the yellow LED flashes once per second, and the red LED is off. • Non-critical alarm—The green LED is solid green, the yellow LED flashes three times per second, and the red LED is off. • Unacknowledged critical error—The red LED flashes three times per second. • Acknowledged critical error—The red LED is solid.
I	LED status indicators: <ul style="list-style-type: none"> • HUB—The LED is green when FPGA video processing is running correctly, orange when FPGA video processing is not configured, and red when a failure occurs. • SMS—The LED is green when the screen management system (SMS) is running correctly, orange when the SMS or system controller has not booted, and red when a failure occurs. • INPUT—The LED is green when FPGA video input is running correctly, orange when FPGA is not configured, and red when a failure occurs. • Power—The LED is green when the low voltage power supply (LVPS) is operating and red when a failure has occurred. The LED is not illuminated when the LVPS is not on.
J	Connects the projector to 3D devices.
K	Connects the projector to ingest devices.
L	Connects the projector to input devices with an HDMI connection.
M	Connects the projector to external automation or automation devices.
N	Connects the projector to the touch panel (VGA-Out and Screen Power).
O	Management Ethernet port (10/100/1000 base-T) and connects the projector to USB devices, including the touch panel screen.
P	Two Ethernet ports connecting the projector to network-attached storage (NAS) devices and the Library Media Server (LMS) network, if applicable. The Media port can also be used for content transfer.

Connecting the projector to a computer

To display content from a computer, connect it to the projector.

1. To connect the main input card of the projector, connect an Ethernet cable to the Management Ethernet port on the projector and the other end to your computer.

2. To communicate with the projector, add the projector to the same network as the computer.

Connecting devices to the 3D sync terminal

For information on connecting devices to the 3D sync terminal, see the *CP2308 User Manual*.

Adjusting the image

Learn how to adjust image geometry so it displays correctly.

Activating the Intelligent Lens System

Activate the Intelligent Lens System (ILS) to automatically adjust the position of the lens.

1. In the left navigation menu, tap **Service Setup** > **Preferences**.
2. Tap **Lens/ILS**.
3. In the right pane, tap the **ILS Installed** slider.
The color of the slider changes to green to indicate the ILS is active.

Calibrating the ILS automatically

Use the Auto Calibrate feature of the Intelligent Lens System (ILS) to find and compensate for motor backlash, and to determine the movement range for the currently installed lens.

1. In the left navigation menu, tap **Image Settings** > **ILS File Setup**.
2. Tap **Create**. 
3. Type a name for the ILS file and tap **Create**.
4. Tap **Auto Calibrate**.
5. Tap **Continue**.

Correcting vignetting

An image that is brighter at the center than it is at the sides needs vignetting correction.

If your image suffers from vignetting, the lens has reached the end of its offset travel range. If your installation does not allow the image to be centered with the center of the screen, move the entire projector in the direction of lens travel.

Correcting keystone effect

Learn how to adjust the image to correct keystone effect.

Keystone effect occurs when you project an image onto the screen at an angle. As a result, the image appears distorted and resembles a trapezoid.

If the image suffers from slight keystone effect, it can be corrected with electronic cropping.

If the keystone effect is severe, you can unevenly adjust the feet to compensate for projector tilt. It is recommended that you use lens offset to align the center of the image to the center of the screen before you correct the keystone effect.

If one side of the image is longer than another, *adjust the tilt and level of the projector* (on page 12).

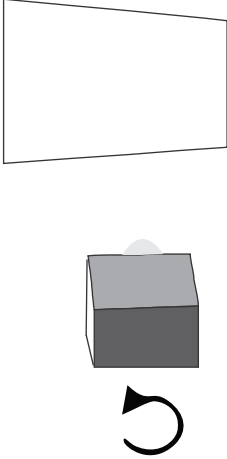
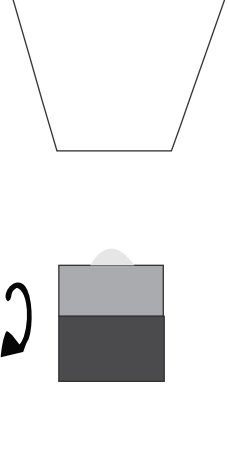

When making the adjustments, set the light source to minimum power.

Horizontal keystone	Vertical keystone
	
Projector skewed horizontally to the screen	Projector tilted vertically to the screen

Adjusting vertical boresight

Perform a top and bottom boresight adjustment to fix image focus issues that cannot be corrected by aligning the projector to the screen and focusing the lens.



Caution! If not avoided, the following could result in minor or moderate injury.

- This procedure must be performed by Christie qualified technicians.

Ensure that the projector is perpendicular to the screen before adjusting boresight.

We recommend that you complete a top and bottom boresight adjustment before adjusting the horizontal boresight.

A boresight adjustment should only be made when the image cannot be focused uniformly on the screen by aligning the projector to the screen and focusing the lens. When adjusting boresight, you must maintain the boresight distance from the lens to the prism plane set by Christie. For example, when you move the top screw outward, turn the bottom two boresight screws to maintain the overall distance.

Ensure that the boresight lockdown screws are adequately tightened. Not adequately tightening the boresight screws can result in excessive onscreen image vibration. After adjusting boresight, evaluate the onscreen image vibration and re-adjust if needed.

1. Remove the lens surround.
2. Display the DC2K Boresight test pattern.
3. Loosen the set screw (B).

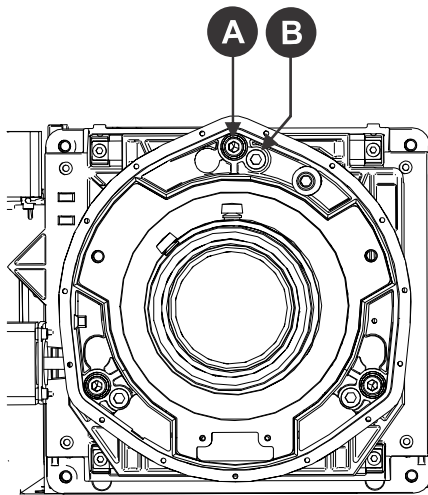

A	Cap screw: Adjusts top and bottom boresight
B	Set screw: Locks or unlocks the cap screw

4. Turn the vertical cap screw (A) 1/8 of a turn counter-clockwise.
Only adjust vertical boresight 1/8 of a turn or less at one time to maintain optimal lens performance (factory setup of absolute lens distance to the prism). It is critical that you count each turn of the cap screws to ensure accurate adjustment.
5. Adjust both left and right horizontal adjusters by half the number of turns, in the opposite direction of the vertical adjust.
For example, if the vertical adjust cap screw was turned 1/8 of a turn, the left and right horizontal cap screws should be turned 1/16 of a turn in the opposite direction.
6. Check the screen each time an adjustment is made. If the quality of the projected image has degraded, turn the vertical adjust cap screw 1/8 of turn clockwise. Ensure the left and right horizontal adjusters are adjusted equally in the opposite direction to correct axial focus. The 1/8 of a turn is a suggestion only and can be less if needed; however, it should never be exceeded. Always compensate both left and right horizontal adjustments according to the vertical adjustment.
7. Check the image after each adjustment. Continue to make adjustments until both top and bottom are equally sharp. To make sure the lens is in the same relative position, adjust the left and right horizontal adjusters in the opposite direction at the same time.
8. When the top and bottom of the image are equally in focus lock the set screw to hold it in position. Recheck the image.
9. If additional adjustment is required, try adjusting horizontal boresight.
10. Replace the lens surround.

Adjusting horizontal boresight

Perform a horizontal boresight adjustment when the image cannot be focused uniformly on the screen by aligning the projector to the screen and focusing the lens.



Caution! If not avoided, the following could result in minor or moderate injury.

- This procedure must be performed by Christie qualified technicians.

Typically, horizontal boresight does not require adjustment. It should only be adjusted if a large horizontal angular offset to the screen is required.

When adjusting boresight, you must maintain the boresight distance from the lens to the prism plane set by Christie. For example, when you move the top screw outward, turn the bottom two boresight screws to maintain the overall distance.

Only adjust horizontal boresight 1/8 of a turn or less at one time to maintain optimal lens performance (factory setup of absolute lens distance to the prism). It is critical that you count each turn of the cap screws to ensure accurate adjustment.

Ensure that the boresight lockdown screws are adequately tightened. Not adequately tightening the boresight screws can result in excessive onscreen image vibration. After adjusting boresight, evaluate the onscreen image vibration and re-adjust if needed.

1. Remove the lens surround.
2. Display the DC2K Boresight test pattern.
3. Loosen the right boresight set screw (B).

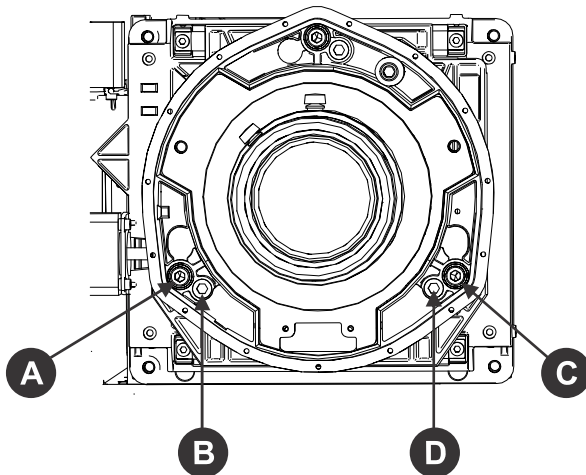

A	Right Boresight Cap Screw
B	Right Boresight Set Screw
C	Left Boresight Cap Screw
D	Left Boresight Set Screw

4. Turn the right boresight cap screw (A) 1/16 of a turn clockwise.
5. Adjust the left boresight cap screw (C) equally in the opposite direction.
6. If the quality of the projected image has not improved, turn the right boresight cap screw 1/16 of turn counter-clockwise. Make sure the left adjuster is adjusted equally in the opposite direction.
7. Check the screen each time an adjustment is made. The right-side adjustments affect the top right and bottom left points on the screen. Once both cross hairs are in focus, lock the set screw for right boresight.
8. Repeat steps 5 to 7 for the left side.
9. Verify that each corner of the screen is equally in focus.
If this is not the case, repeat vertical boresight.

Adjusting digital micromirror device convergence

A digital micromirror device (DMD) convergence problem occurs when one or more projected colors (red, green, blue) appears misaligned when examined with a convergence test pattern.

Normally, the three colors should overlap precisely to form pure white lines throughout the image and one or more poorly converged individual colors may appear adjacent to some or all of the lines.

Contact your Christie accredited service technician to correct DMD convergence issues.

Adjusting the fold mirror

Learn how to align the fold mirror with the optical system to correct an image with missing or shadowy corners or edges.

1. Remove the top cover.
2. Display the RGB-12bit-Full Screen White test pattern.
3. Insert a hex driver in the first set screw (A) and a hex driver in the first cap screw (B).

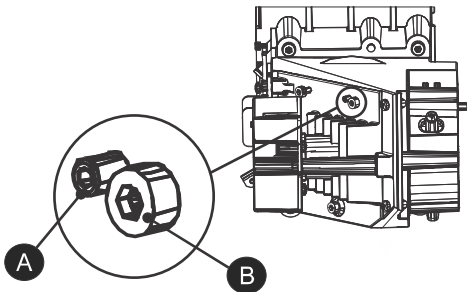

4. Equally turn the set screw (A) and cap screw (B) in opposite directions until the black corner is removed.
5. If the black corner remains, insert a hex driver in the second set screw (C) and a hex driver in the second cap screw (D).

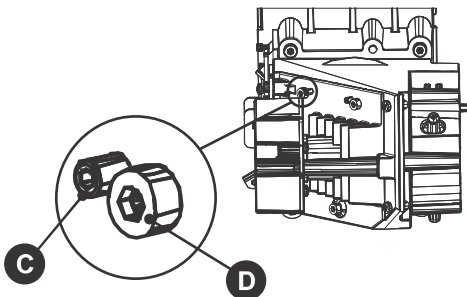

6. Equally turn the set screw (C) and cap screw (D) in opposite directions until the black corner is removed.
7. Replace the top cover.

Calibrating the color

Learn how to create Measured Color Gamut Data (MCGD) files to correct on-screen colors.

Using a colorimeter, measure the colors displayed on the screen from the center of the audience viewing location. For more information, see the *CP2308 User Manual*.

CP2308 Specifications

Learn about the product specifications. Due to continuing research, specifications are subject to change without notice.

Physical specifications

Learn the dimensions and weight of the projector.

Item	Description
Size (L x W x H) (without the lens, and with the feet at minimum length)	697 mm (32.70 inches) x 688 mm (27.10 inches) x 395 mm (15.60 inches)
Weight—installed with the lens	53.75 kg (119 lbs)
Shipping weight	77.2 kg (170 lbs)
Touch panel (W x H x D)	248.2 mm x 166.8 mm x 36.3 mm

Power specifications

Learn the power requirements for the projector.

AC input (A)

Item	Description
Voltage range	200 - 240 VAC
Line frequency	50/60 Hz nominal
Inrush current	100 A (at 240 VAC)
Current consumption	16 A maximum (at 200 VAC)
Power consumption	3200 W maximum
Current rating of AC input	IEC-320-C19/20 A

UPS AC input (B)

Item	Description
Activation	Discrete switch above the power inlet cord(s)
UPS inlet connector (rating for powering main electronics)	IEC-320-C13/10 A, 240 VAC

Item	Description
UPS type	Universal 100-240 VAC
Line frequency	50/60 Hz nominal
Current consumption	4 A maximum (at 100 VAC)

Environmental specifications

Learn about the environment requirements for projector while operating and not operating.

Operating environment

Item	Description
Temperature	15°C to 35°C (59°F to 95°F)
Humidity (non-condensing)	20% to 80%
Altitude	0 - 3000 meters
Maximum ambient temperature	35°C

Non-operating environment

Item	Description
Temperature	-20°C to 60°C (-4°F to 140°F)
Humidity (non-condensing)	0% to 95%

Display specifications

Learn the display specifications of the projector.

Panel resolution and refresh rate

Pixel format (H x V square pixels)	2048 x 1080
Processing path	23.97 - 120Hz

Achievable brightness (measured at screen center)

Lamp	Minimum	Nominal	Maximum
700 W (CDXL-14M)	1,170 lumens	1,300 lumens	1,430 lumens
1.4 kW (CDXL-14M)	2,950 lumens	3,300 lumens	3,630 lumens
1.6 kW (CDXL-16M)	4,950 lumens	5,500 lumens	6,050 lumens
1.9 kW (CDXL-19SC)	6,300 lumens	7,000 lumens	7,700 lumens

Lamp	Minimum	Nominal	Maximum
2.1 kW (CDXL-21S1)	7,200 lumens	8,000 lumens	8,800 lumens

Achievable contrast ratio

400:1 ANSI
1900:1 Full Frame ON/OFF

Color and gray scale

Displayable colors	35.2 trillion
Gray scale resolution	45 bits total linear, 15 bits per RGB component

White point

Nominal White (full white, after calibration to Telecine mode, Theaters)
x = 0.314 ± 0.006
y = 0.351 ± 0.006

Gamma

Theater (nominal)	2.6 ± 5%
-------------------	----------

Control signal compatibility

Learn the control signal compatibility for the projector.

Ethernet port

Interface	10Base-T/(IEEE 802.3)/100BASE-TX(IEEE 802.3u)/1000BASE-TX(IEEE 802.3ab)
Connector	Female RJ-45
Bit rate	1000 Mbps

eSATA/USB 2.0 ingest

Interface	USB 2.0/SATA revision 2.0
Connector	USB Type "A"/eSATA
Bit rate	480 Mbps/3.0 Gbps
Available power for devices	2A @ 5V (TBC)

USB 3.0 ingest

Interface	USB 3.0
Connector	USB Type "A"
Bit rate	5.0 Gbps
Available power for devices	2A @ 5V (TBC)

GPIO port

Interface	Opto-LED inputs, relay outputs
Number of I/O lines	16 - 4 inputs, 4 outputs, 1 health signal output
Connector	Terminal blocks
Wire size accepted	28-20 AWG
GPI diode forward current	5mA nominal, 50mA maximum
GPI diode forward voltage	1.1V nominal, 1.4V maximum (@ 5mA)
GPI relay continuous current	1A
GPO relay output rating	60V
Output supply voltage	5VDS @ 200 mA

3D port

Interface	Proprietary 3D connector
Connector	15-pin subminiature D, female
Bit rate	115,200 bps
Flow control	Software
Data format	1 start bit, 8 data, 1 stop bit, no parity
Communication protocol	RS232 and GPIO

AES3 audio output

Interface	16-Channel AES3 Digital Audio
Connector	RJ-45

VGA user interface display

Interface	VGA
Connector	15-pin high density subminiature D, female

DVI user interface display

Interface	DVI
Connector	24-pin DVI-I female

HDMI

Interface	HDMI v1.4A
Connector	HDMI Receptable with locking

USB touch panel input

Interface	USB 2.0
Connector	USB Device Standard Size ("Series A")
Bit rate	480 Mbps

Touch panel specifications

Learn the specifications of the touch panel.

Type of Display	Color LCD, backlit
Display Size	256.54 mm (10.1 inches) diagonal
Display Resolution (H x V pixels)	1280 x 800
Maximum Dimensions (W x H x D)	248.2 mm x 166.8 mm x 36.3 mm
Communication Interface with Projector	VGA/USB
Power Requirement	6W (12 V @ 500 mA)
Interface Connector	VGA/USB/ Power on custom cable

Lamp specifications

Learn the specifications of the lamp.

Type: Xenon Short Arc Lamp

Projectors typically force a 10 minute cool down period. Ensure you do not re-strike the lamp any sooner than two minutes into this cool down period since hot re-strikes reduce lamp life. The period required to reach full brightness is 20 minutes (maximum).

Power (software adjustable)

Item	Description
CDXL-14M (1.4kW)	700 W min., 1400 W nom., 1540 W max.

Item	Description
CDXL-16M (1.6kW)	1000 W min., 1600 W nom., 1760 W max.
CDXL-19SC	1610 W min., 1900 W nom., 1900 W max.
CDXL-21S1 (2.1kW)	1260 W min., 2100 W nom., 2300 W max.

The ballast is power regulated and has a maximum current of 97 A. Therefore the maximum power specification for a given lamp may not be achievable until the lamp has aged, since lamp voltage increases with hours of use.

Lamp expiry hours

This table specifies the maximum hours the projector lamp can operate before replacement:

Lamp Type	Expected Life
CDXL-14M	3500 hours
CDXL-16M	3500 hours
CDXL-19SC	1800 hours
CDXL-21S1	1500 hours

Accessories

Learn what accessories are available for the projector.

Standard (sold with product)

- Touch panel with interface cable
- User Manual (with USB flash drive containing additional technical documentation)
- Power Cord
- Lamp
- Lens
- Air Filters
- Stacking Kit

Zoom lenses

- 1.2-1.72 .69" DLPCine Zoom (108-494108-XX)
- 1.33-2.1 .69" DLPCine Zoom (108-495109-XX)
- 1.62-2.7 .69" DLPCine Zoom (108-496100-XX)
- 2.09-3.9 .69" DLPCine Zoom (108-497101-XX)

Replacement lamps

- CDXL-14M (003-003066-XX)

- CDXL-16M (003-003900-XX)
- CDXL-19SC (003-005366-XX)
- CDXL-21S1 (003-004258-XX)

Air filters

- Replacement Light Engine Air Filter (003-004460-XX)
- Replacement Air Filter (003-002311-XX)
- Replacement Light Engine Washable Air Filter (003-004654-XX)
- Replacement Card Cage Washable Air Filter (003-004655-XX)

Miscellaneous

- Rack Stand (108-416102-XX)
- Extractor Adapter Kit (119-103105-XX)

Regulatory

This product conforms to the latest regulations and standards related to product safety, environmental requirements, and electromagnetic compatibility (EMC).

Safety

- CAN/CSA C22.2 No. 60950-1
- ANSI/UL 60950-1 - Information Technology Equipment – Safety – Part 1: General Requirements
- IEC 60950-1 IEC/EN 60950-1 - Information Technology Equipment – Safety – Part 1: General Requirements
- EN 60950-1

Electro-magnetic compatibility

Emissions

- FCC CFR47, Part 15, Subpart B, Class A - Unintentional Radiators
- CAN ICES-003 (A)/NMB-003 (A) - Information Technology Equipment (Including Digital Apparatus) - Limits and Methods of Measurement
- CISPR 32/EN 55032, Class A

Immunity

- CISPR 24/EN55024 EMC Requirements

Environmental

EU Directive (2011/65/EU) on the restriction of the uses of certain hazardous substances (RoHS) in electrical and electronic equipment and the applicable official amendment(s).

EU Regulation (EC) No. 1907/2006 on the registration, evaluation, authorization and restriction of chemicals (REACH) and the applicable official amendment(s).

EU Directive (2012/19/EU) on waste and electrical and electronic equipment (WEEE) and the applicable official amendment(s).

China Ministry of Information Industry (along with 7 other Government Agencies) Order No.32 (01/2016) on the control of pollution caused by electronic information products, hazardous substances concentration limits (GB/T 26572 - 2011), and the applicable product marking requirement (SJ/T 11364 - 2014).

International packaging recycling mark requirements.

- EU Directive (94/62/EC) on packaging and packaging waste
- China packaging recycling mark standard (GB18455-2010)

Corporate offices

Christie Digital Systems USA, Inc.
Cypress
ph: 714 236 8610

Christie Digital Systems Canada Inc.
Kitchener
ph: 519 744 8005

Worldwide offices

Australia
ph: +61 (0) 7 3624 4888

Brazil
ph: +55 (11) 2548 4753

China (Beijing)
ph: +86 10 6561 0240

China (Shanghai)
ph: +86 21 6278 7708

France
ph: +33 (0) 1 41 21 44 04

Germany
ph: +49 2161 664540

India
ph: +91 (080) 6708 9999

Japan (Tokyo)
ph: 81 3 3599 7481

Korea (Seoul)
ph: +82 2 702 1601

Mexico
ph: +52 55 4744 1790

Republic of South Africa
ph: +27 (0)11 510 0094

Russian Federation
and Eastern Europe
ph: +36 (0) 1 47 48 100

Singapore
ph: +65 6877 8737

Spain
ph: +34 91 633 9990

United Arab Emirates
ph: +971 4 3206688

United Kingdom
ph: +44 (0) 118 977 8000

United States (Arizona)
ph: 602 943 5700

United States (New York)
ph: 646 779 2014

Independant sales consultant offices

Italy
ph: +39 (0) 2 9902 1161



For the most current technical documentation, visit www.christiedigital.com.

