The top half of the page features a complex, abstract background of overlapping, semi-transparent blue triangles and polygons in various shades of blue, creating a dynamic, crystalline effect. This pattern transitions into a white background at the bottom.

Installation and Setup Guide
020-103555-03

CP2420-Xe and CP4420-Xe

CHRISTIE®

NOTICES

COPYRIGHT AND TRADEMARKS

Copyright © 2023 Christie Digital Systems USA Inc. All rights reserved.

All brand names and product names are trademarks, registered trademarks or trade names of their respective holders.

GENERAL

Every effort has been made to ensure accuracy, however in some cases changes in the products or availability could occur which may not be reflected in this document. Christie reserves the right to make changes to specifications at any time without notice. Performance specifications are typical, but may vary depending on conditions beyond Christie's control such as maintenance of the product in proper working conditions. Performance specifications are based on information available at the time of printing. Christie makes no warranty of any kind with regard to this material, including, but not limited to, implied warranties of fitness for a particular purpose. Christie will not be liable for errors contained herein or for incidental or consequential damages in connection with the performance or use of this material. Our centers of excellence for manufacturing in Kitchener, Ontario, Canada and in Shenzhen, China are ISO 9001:2015 Quality Management System-certified.

Christie is committed to making our documents free from language bias; however, we are not responsible for the language used on any linked or third-party documentation.

For the most current technical documentation and office contact information, visit <http://www.christiedigital.com>.

Warranty

Products are warranted under Christie's standard limited warranty, the details of which are available at <https://www.christiedigital.com/help-center/warranties/> or by contacting your Christie dealer or Christie.

PREVENTATIVE MAINTENANCE

Preventative maintenance is an important part of the continued and proper operation of your product. Failure to perform maintenance as required, and in accordance with the maintenance schedule specified by Christie, voids the warranty. For preventative maintenance schedules, refer to www.christiedigital.com.

REGULATORY

The product has been tested and found to comply with the limits for a Class A digital device, pursuant to Part 15 of the FCC Rules. These limits are designed to provide reasonable protection against harmful interference when the product is operated in a commercial environment. The product generates, uses, and can radiate radio frequency energy and, if not installed and used in accordance with the instruction manual, may cause harmful interference to radio communications. Operation of the product in a residential area is likely to cause harmful interference in which case the user will be required to correct the interference at the user's own expense. Changes or modifications not expressly approved by the party responsible for compliance could void the user's authority to operate the equipment

CAN ICES-3 (A) / NMB-3 (A)

이 기기는 업무용(A급)으로 전자파적합등록을 한 기기이오니 판매자 또는 사용자는 이점을 주의하시기 바라며, 가정 외의 지역에서 사용하는 것을 목적으로 합니다.

ENVIRONMENTAL



The product is designed and manufactured with high-quality materials and components that can be recycled and reused. This symbol  means electrical and electronic equipment, at their end-of-life, should be disposed of separately from regular waste. Please dispose of the product appropriately and according to local regulations. In the European Union, separate collection systems are for used electrical and electronic products.

If printing this document, consider printing only the pages you need and select the double-sided option.

Please help us to conserve the environment we live in!

Notation

Learn the hazard and information symbols used in the product documentation.



Danger messages indicate a hazardous situation which, if not avoided, results in death or serious injury.



Warning messages indicate a hazardous situation which, if not avoided, could result in death or serious injury.



Caution messages indicate a hazardous situation which, if not avoided, could result in minor or moderate injury.



Notice messages indicate a hazardous situation which, if not avoided, may result in equipment or property damage.



Information messages provide additional information, emphasize or provide a useful tip.

Content

Introduction.	6
Product documentation.	6
Related documentation.	6
Safety precautions.	7
General safety precautions.	7
Lamp safety precautions.	8
AC power precautions.	8
Light intensity hazard distance.	9
Product labels.	11
Key features.	14
List of components.	14
Accessories.	15
CineMaster cinema calculator tool.	16
Contact your dealer.	16
Technical support.	17
Installing and setting up.	18
Site requirements.	18
Projector components.	19
Preparing the installation site.	20
Required tools and components.	20
Lifting and positioning the projector.	20
Adjusting the projector tilt and level.	21
Installing the optional touch panel control.	22
Connecting external exhaust ducting.	22
Installing the primary lens.	24
Installing the zoom motor kit.	25
Installing the lamp.	26
Installing the Integrated Media Block (IMB).	27
Connecting the projector to AC power with a permanent connection.	28
Connecting the projector to AC power with a pluggable type B connection.	30
Connecting the projector to an uninterruptible power supply (optional).	31
Turning on the projector for the first time.	31
Disposing of the product packaging.	31

Video Input panel.	32
HDMI video source.	33
HDMI video formats.	33
SDI video source.	35
SDI video formats.	35
DisplayPort video source.	41
DisplayPort video formats.	41
Integrated Media Block (IMB) video source.	42
Series 2 Integrated Media Block (IMB) video formats.	43
Series 4 Integrated Media Block (IMB) video formats.	44
HDMI video source connection from an Integrated Media Block (IMB).	47
SDI video source connection from an Integrated Media Block (IMB).	47
GPIO connector.	47
Operation.	50
Turning on the projector.	50
Turning off the projector.	50
Projector states.	50
Adjusting the image.	52
Maximizing light output.	52
Calibrating the Intelligent Lens System.	52
Aligning the image.	52
Adjusting the offset.	53
Adjusting offset by using an ILS	54
Correcting vignetting.	54
Correcting keystone effect.	54
Adjusting the left and right boresight	55
Adjusting the top and bottom boresight	57
Electronic Color Correction (ECC).	59
Mechanically adjusting digital micromirror device (DMD) convergence for CP2420-Xe.	60
Mechanically adjusting digital micromirror device (DMD) convergence for CP4420-Xe.	62
Electronically adjusting convergence.	64
Adjusting the fold mirror.	65
Aligning the integrator module.	66
Calibrating the color.	67
Regulatory.	68
Safety.	68

Electro-magnetic compatibility.	68
Emissions.	68
Immunity.	68
Environmental.	69

Introduction

This manual is intended for professionally trained operators of Christie high-brightness CP2420-Xe/CP4420-Xe projection systems.

For complete product documentation and technical support, go to www.christiedigital.com.

Product documentation

For installation, setup, and user information, see the product documentation available on the Christie website. Read all instructions before using or servicing this product.

To access the documentation from the Christie website:

- Go to this URL: <https://bit.ly/3vxrm4Y> or <https://www.christiedigital.com/products/cinema/projection/cinelife-plus-series/>.
- Scan the QR code using a QR code reader app on a smartphone or tablet.



- On the product page, select the model and switch to the **Downloads** tab.

Related documentation

Additional information on this product is available in the following documents.

- *CP2420-Xe and CP4420-Xe Product Safety Guide (P/N: 020-103564-XX)*
- *CineLife+ User Guide (P/N: 020-103073-XX)*
- *CineLife+ Serial Commands Guide (P/N: 020-103075-XX)*
- *CP2420-Xe and CP4420-Xe Service Guide (P/N: 020-103566-XX)*

Safety precautions

Learn about the safety precautions related to the Christie CP2420-Xe/CP4420-Xe projectors. This projector is intended for use in a cinema environment.

General safety precautions

Read all safety and warning guidelines before installing or operating the projector.



Warning! If not avoided, the following could result in death or serious injury.

- TRIP OR FIRE HAZARD! Position all cables where they cannot contact hot surfaces, be pulled, be tripped over, or damaged by persons walking on or objects rolling over the cables.
- This product must be installed within a restricted access location not accessible by the general public.
- Only personnel who are trained on the precautions for the restricted access location can be granted entry to the area.
- Install the product so users and the audience cannot enter the restricted area at eye level.
- ELECTRICAL and BURN HAZARD! Use caution when accessing internal components.
- High leakage current present when connected to IT power systems.
- FIRE AND SHOCK HAZARD! Use only the attachments, accessories, tools, and replacement parts specified by Christie.
- FIRE HAZARD! Do not use a power cord, harness, or cable that appears damaged.
- A minimum of four people or appropriately rated lift equipment is required to safely lift, install, or move the product.
- Do not install or operate the projector in any position that does not meet the stated product specifications for alignment and orientation.



Caution! If not avoided, the following could result in minor or moderate injury.

- Only Christie qualified technicians are permitted to open product enclosures.

Lamp safety precautions

Read all safety and warning guidelines before installing the projector lamp.



Warning! If not avoided, the following could result in death or serious injury.

- This procedure must be performed by Christie qualified technicians.
- EXPLOSION HAZARD! Always wear protective safety clothing (gloves, jacket, face shield) approved by the manufacturer whenever the lamp door is open or when handling the lamp. Any local or federal specifications take precedence over Christie's protective clothing recommendations.
- Do not open the lamp door while the lamp is on.
- EXPLOSION HAZARD! Allow sufficient time for the lamp to cool down before powering down the product, disconnecting it from AC, and opening the lamp door.
- EXPLOSION HAZARD! Do not stress the glass of a lamp or bare bulb in any way.
- EXPLOSION HAZARD! Lamps and bare bulbs, even when packaged, may explode if dropped or mishandled.
- EXPLOSION HAZARD! Handle a lamp by the cathode and anode end shafts only. Do not handle the lamp by the glass.
- EXPLOSION HAZARD! Do not over-tighten the lamp.
- Do not look directly into the lens when the light source is on. The extremely high brightness can cause permanent eye damage.
- FIRE HAZARD! Keep hands, clothes, and all combustible material away from the concentrated light beam of the projector.



Caution! If not avoided, the following could result in minor or moderate injury.

- Improper installation of the lamp can damage the projector.
- Incorrect lamp power supply and igniter connections can damage the product.

AC power precautions

Read all safety and warning guidelines before connecting to AC power.



Warning! If not avoided, the following could result in death or serious injury.

- SHOCK HAZARD! Only use the AC power cord provided with the product or recommended by Christie.
- FIRE AND SHOCK HAZARD! Do not attempt operation unless the power cord, power socket, and power plug meet the appropriate local rating standards.
- SHOCK HAZARD! Do not attempt operation if the AC supply is not within the specified voltage and current, as specified on the license label.
- SHOCK HAZARD! The optional UPS power cord must be inserted into an outlet with grounding.
- SHOCK HAZARD! Disconnect the product from AC before installing, moving, servicing, cleaning, removing components, or opening any enclosure.
- Install the product near an easily accessible AC receptacle.



Caution! If not avoided, the following could result in minor or moderate injury.

- FIRE HAZARD! Do not use a power cord, harness, or cable that appears damaged.
- FIRE OR SHOCK HAZARD! Do not overload power outlets and extension cords.
- SHOCK HAZARD! Power supply uses double pole/neutral fusing.

Light intensity hazard distance

This projector has been classified as Risk Group 3 as per the IEC 62471-5:2015 standard due to possible hazardous optical and thermal radiation being emitted.



Warning! If not avoided, the following could result in serious injury.

- PERMANENT/TEMPORARY BLINDNESS HAZARD! No direct exposure to the beam must be permitted.
- PERMANENT/TEMPORARY BLINDNESS HAZARD! Operators must control access to the beam within the hazard distance or install the product at the height that prevents exposure of spectators' eyes within the hazard distance. The hazard zone must be no lower than 2.5 meters/8.2 feet (US installations) or 2.0 meters/6.6 feet (global installations) above any surface upon which any persons are permitted to stand and the horizontal clearance to the hazard zone must be a minimum 1.0 meters.
- EXTREME BRIGHTNESS! Do not place reflective objects in the product light path.

The following show the zones for ocular and skin hazard distances.

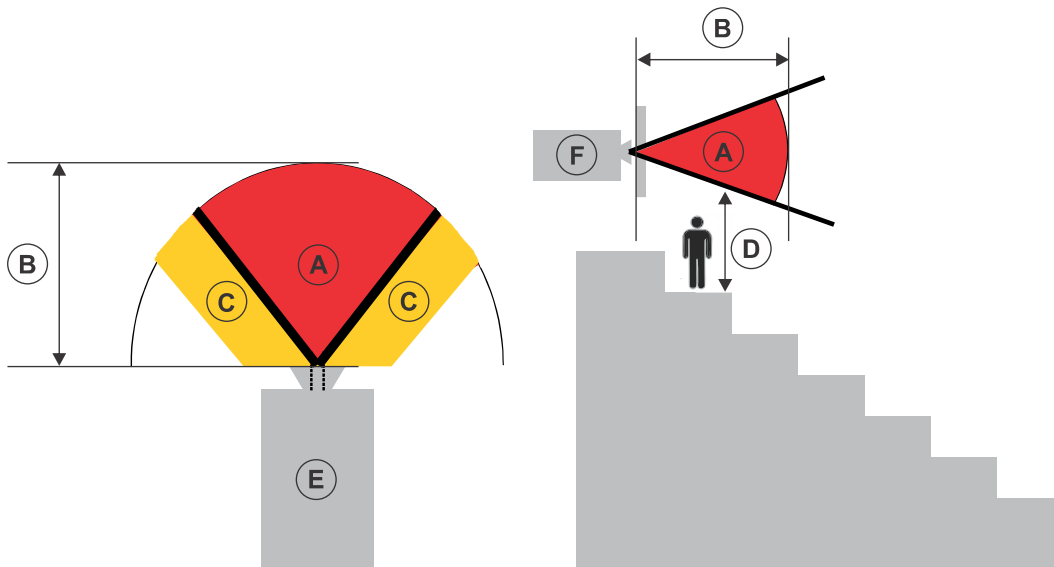

- A—Hazard zone. The region of space where the projection light from the projector is above emission limits for Risk Group 2. The light intensity may cause eye damage after a momentary or brief exposure (before a person can avert their eyes away from the light source). The light may cause skin burns to occur.
- B—Hazard distance. Operators must control access to the beam within the hazard distance or install the product preventing potential exposure of the spectators' eyes from being in the hazard distance.
- C—No access zone. Horizontal clearance of the no access zone must be a minimum of 1.0 meters (3.3 feet).

- D—Vertical distance to hazard zone. The hazard zone must be no lower than 2.5 meters/8.2 feet (US installations) or 2.0 meters/6.6 feet (global installations) above any surface upon which any persons are permitted to stand.

If the vertical distance to hazard zone requirement (Zone D) is satisfied, the horizontal clearance distance (Zone C) is not needed.

- E—Represents the top view of the projector.
- F—Represents the side view of the projector.

Projection lens	Part number	Hazard distance (m)	Category
High brightness			
0.9:1 zoom	38-809071-XX	N/A	RG2
1.25-1.83:1 zoom	108-342100-XX	See hazard distance graph below	RG3
1.45-2.05:1 zoom	108-335102-XX		
1.6-2.4:1 zoom	108-336103-XX		
1.8-3.0:1 zoom	108-337104-XX		
2.15-3.6:1 zoom	108-338105-XX		
3.0-4.3:1 zoom	108-278101-XX		
4.3-6.0:1 zoom	108-279101-XX		
5.5-8.5:1 zoom	108-280101-XX		
1.25-1.90:1 premium zoom	163-141107-XX		
1.49-2.03:1 premium zoom	163-142108-XX		
1.6-2.32:1 premium zoom	163-143109-XX		
1.82-2.98:1 premium zoom	163-144100-XX		
High contrast			
1.25-1.83:1 zoom	152-117100-XX	See hazard distance graph below	RG3
1.45-2.05:1 zoom	152-118101-XX		
1.6-2.4:1 zoom	152-119102-XX		
1.8-3.0:1 zoom	152-120104-XX		
2.15-3.6:1 zoom	108-404109-XX		
1.25-1.90:1 premium zoom	152-155102-XX		
1.49-2.03:1 premium zoom	152-156103-XX		
1.6-2.32:1 premium zoom	152-157104-XX		
1.82-2.98:1 premium zoom	152-158105-XX		

CP2420-Xe and CP4220-Xe hazard distances

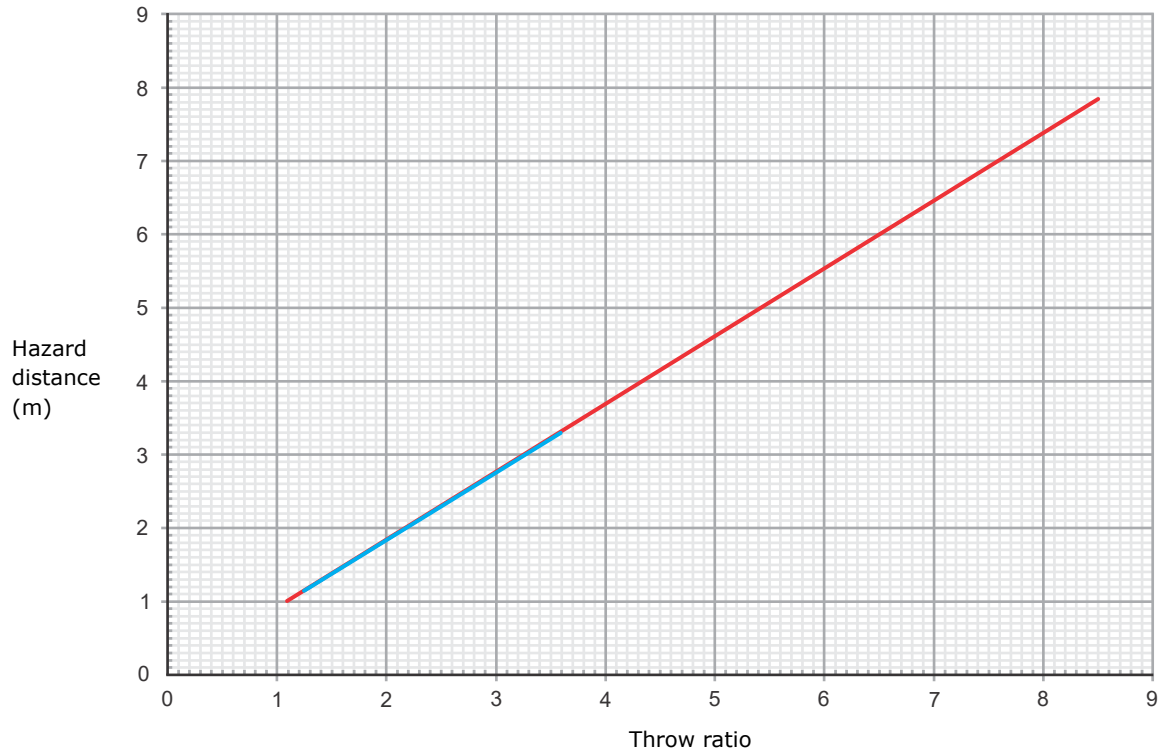

- High brightness lenses
- High contrast lenses

Product labels

Learn about the labels that may be used on the product. Labels on your product may be yellow or black and white.

General hazards

Hazard warnings also apply to accessories once they are installed in a Christie product connected to power.

Fire and Shock Hazard



To prevent fire or shock hazards, do not expose this product to rain or moisture.
 Do not alter the power plug, overload the power outlet, or use it with extension cords.
 Do not remove the product enclosure.
 Only Christie qualified technicians are authorized to service the product.

Electrical Hazard



Risk of electric shock.
Do not remove the product enclosure.
Only Christie qualified technicians are authorized to service the product.



Warning! If not avoided, the following could result in death or serious injury.



Electric shock hazard. To avoid personal injury, disconnect all power sources before performing maintenance or service.



Electrocution hazard. To avoid personal injury, always disconnect all power sources before performing maintenance or service procedures.



Explosive material hazard. To avoid personal injury, disconnect all power sources before performing maintenance or service, and wear Christie-approved protective clothing.



Optical radiation hazard. To avoid personal injury, never look directly at the light source.



Voltage hazard. To avoid personal injury, always disconnect all power sources before performing maintenance or service procedures.



Caution! If not avoided, the following could result in minor or moderate injury.



Hot surface hazard. To avoid personal injury, allow the product to cool for the recommended cool down time before touching or handling for maintenance or service.



Burn hazard. To avoid personal injury, allow the product to cool for the recommended cool down time before handling for maintenance or service.



Moving parts hazard. To avoid personal injury, keep hands clear and loose clothing tied back.



Moving fan blades. To avoid personal injury, keep hands clear and loose clothing tied back. Always disconnect all power sources before performing maintenance or service procedures.



Notice. If not avoided, the following could result in property damage.



General hazard.



Not for household use.

Mandatory actions



Caution! If not avoided, the following could result in minor or moderate injury.



Consult the service manual.



Disconnect all power sources before performing maintenance or service procedures.

Electrical labels



Indicates the presence of a protective earth ground.



Indicates the presence of an earth ground.

Additional hazard labels



Indicates high leakage current. Earth or ground connection essential before connecting the power supply.



Indicates a light hazard. Do not look directly into the lens. The extreme high brightness can cause permanent eye damage.



Indicates thermal radiation emitted from the product may cause burns.

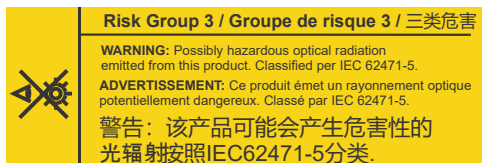

Indicates possible optical radiation emitted from the product.



Indicates the size of the rigid duct to attach to the lamp exhaust.



Indicates the use of the lamp extension nut when installing CDXL-30SD lamps only. This nut must be removed for all other lamp types.



Indicates the use of the lamp duct is mandatory to prevent accumulation of heat in the lamp area.



Indicates the location of the yellow notch filter screw, which should only be adjusted when necessary.

Key features

Learn the important features of the projector.

- Three-chip Digital Light Processing DLP™ light engine
 - CP2420-Xe is 2K 1.2"
 - CP4420-Xe is 4K 1.38"
- Christie CineLife™ Series 4 electronics
- LiteLOC™ for constant image brightness
- Exhaust air extraction

List of components

Verify all components were received with the projector.

- High security key to open the projector service access door

Optional accessories such as an UPS inlet power cord or touch panel are also available.

Accessories

Learn about the accessories (sold separately) available for the projector.

Lenses

Projection lens	Part number
High brightness	
0.9:1 zoom	38-809071-XX
1.25-1.83:1 zoom	108-342100-XX
1.45-2.05:1 zoom	108-335102-XX
1.6-2.4:1 zoom	108-336103-XX
1.8-3.0:1 zoom	108-337104-XX
2.15-3.6:1 zoom	108-338105-XX
3.0-4.3:1 zoom	108-278101-XX
4.3-6.0:1 zoom	108-279101-XX
5.5-8.5:1 zoom	108-280101-XX
1.25-1.90:1 premium zoom	163-141107-XX
1.49-2.03:1 premium zoom	163-142108-XX
1.6-2.32:1 premium zoom	163-143109-XX
1.82-2.98:1 premium zoom	163-144100-XX
High contrast	
1.25-1.83:1 zoom	152-117100-XX
1.45-2.05:1 zoom	152-118101-XX
1.6-2.4:1 zoom	152-119102-XX
1.8-3.0:1 zoom	152-120104-XX
2.15-3.6:1 zoom	108-404109-XX
1.25-1.90:1 premium zoom	152-155102-XX
1.49-2.03:1 premium zoom	152-156103-XX
1.6-2.32:1 premium zoom	152-157104-XX
1.82-2.98:1 premium zoom	152-158105-XX

Lamps

Description	Part number
CDXL-20LB (2.0 kW Xenon)	003-005079-XX
CDXL-20SP (2.0 kW Xenon)	003-004251-XX

Description	Part number
CDXL-20 (2.0 kW Xenon)	03-000695-01P
CDXL-30SP (3.0 kW Xenon)	003-004252-XX
CDXL-30 (3.0 kW Xenon)	03-000696-01P
CDXL-30SD (3.0 kW Xenon)	003-001165-XX

Filters

Description	Part number
Air filter—Five pack	003-001184-XX
Radiator filter	003-003082-XX

Other accessories

Description	Part number
Protective Clothing Safety kit—includes Kevlar gloves, flak jacket, face shield	598900-095
Rack stand	108-282101-XX
Bracket foot lock (for use with rack stand)	116-100101-XX
Touch panel control	163-151108-XX

CineMaster cinema calculator tool

The CineMaster cinema calculator tool helps you calculate and configure the optimal cinema set up. Use this tool to help determine the right projector, lens, and lamp based on the unique needs of your installation, as well as your preferred projector type, screen configuration, and brightness requirements.

<https://cinemaster.christiedigital.com/>

Contact your dealer

Record the information about your installation and keep this information with your records to assist with any servicing of your product. If you encounter a problem, contact your dealer.

Purchase record
Dealer:
Dealer or Christie Sales/Service contact phone number:
Serial number: The serial number can be found on the license label.
Purchase date:

Purchase record

Installation date:

Technical support

Technical support for Christie Cinema products is available at:

- Support.cinema@christiedigital.com
- +1-877-334-4267
- Christie Professional Services: +1-800-550-3061 or NOC@christiedigital.com

Installing and setting up

Learn how to position and install the projector.

Site requirements

To safely install and operate the CP2420-Xe/CP4420-Xe projectors, the installation location must meet these minimum requirements.

Physical operating environment

- Ambient temperature (operating) 10 to 35°C (50 to 95°F)
- Humidity (non-condensing) 10% to 80%
- Operating altitude 0 to 3000 meters (0 to 9843 feet) at 10 to 25°C (50 to 77°F)

External exhaust ducting

The installation site must provide sufficient external exhaust airflow to make sure adequate cooling of the Xenon arc lamp.

- At 25°C (77°F) ambient or less and below 915 meters (3,000 feet), a minimum of 450 CFM is required.
- Above 25°C (77°F) or above 915 meters (3,000 feet), a minimum of 600 CFM is required.

Permanent power connection

The projector must be connected to power using a hard-wired connection. The projector light source (main input) requires the permanent AC connection to operate. There is also an available connector for an uninterruptible power supply (UPS) to provide backup power for the projector electronics only.

Certified wall breakers are required as part of the installation. Breakers must be part of the building and easily accessible. The size of the breaker is determined from the power requirements of the projector and can be up to 30A maximum for the main input and up to 5A maximum for the UPS input.

For the CP2420-Xe, a 30-32A double-pole, UL-listed wall circuit breaker with minimum 3 mm (.12 inches) contact gap is required.

Projector components

Learn about the projector components.

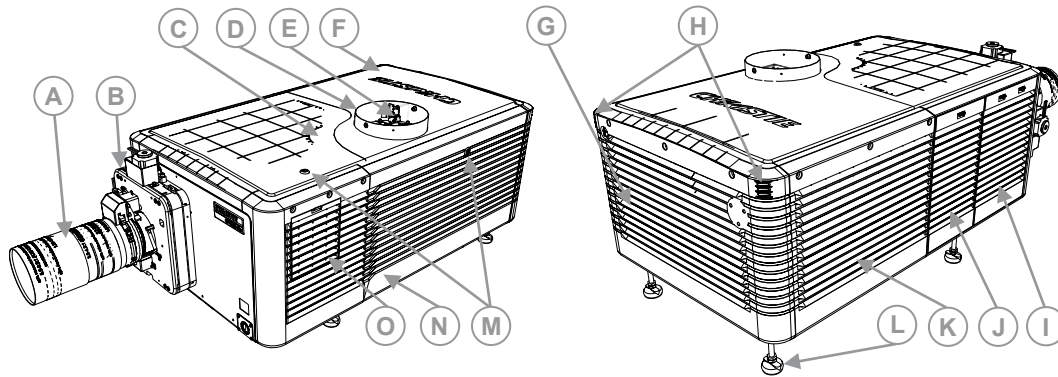

ID	Component	Description
A	Projection lens	A variety of lenses can be used with this cinema projector.
B	Lens mount	Optional motorized lens mount.
C	Front top cover	Provides access to internal components.
D	Exhaust duct	Extracts heated air from the lamp compartment.
E	Vane switch	Monitors the amount of airflow.
F	Rear top cover	Provides access to internal components.
G	Back cover	Provides access to internal components.
H	LED status indicators (x2)	Provide information about the status of the projector.
I	Light engine air filter cover	Provides access to the air filter, which removes particles from the intake air before it circulates in the front compartment to cool the main electronics.
J	Communication panel cover	Provides access to Input connections.
K	LVPS/LPS access panel	Provides access to the lamp power supply (LPS) connections, AC relay, and LVPS.
L	Adjustable feet (x4)	Adjust the tilt of the projector.
M	Security locks	Prevent unauthorized access to projector components.
N	Lamp door	Provides access to the lamp. The lamp door must remain closed and locked for normal operation. Lamp replacement must be performed only by qualified technicians.
O	Left access cover	Provides access to the air filter.

Related information

Accessories (on page 15)

Preparing the installation site

Make sure the installation area is ready for the components.

1. Clear the installation area.
2. Place each component near its installation location.

Required tools and components

The following tools and components are required for installation.

- 12" screwdrivers: Phillips #2 (magnetic) and flat
- Wrenches: 19 mm and 7/8"
- Allen keys: 5 mm and other assorted (metric)
- Heat extractor—Required when the projector is operating at 25°C (77°F) at an elevation of 914 meters (3,000 feet) or less.
- Lamp
- Protective safety clothing approved by Christie
- Lens cleaning tissue and solution

Lifting and positioning the projector

Safely lift and position the projector in the location where it will be used.



Warning! If not avoided, the following could result in death or serious injury.

- A minimum of four people or appropriately rated lift equipment is required to safely lift, install, or move the product.
 - Do not install or operate the projector in any position that does not meet the stated product specifications for alignment and orientation.
1. If installing the projector in the optional rack stand (P/N: 108-282101-XX), follow the instructions provided with the rack stand to install it.
 2. Position each person at the corners of the projector.
 3. Place both hands under the corner, grasping the projector frame.
Do not lift the projector using any feature on the projector cover, such as the cover louvers or lens opening.
 4. Lift up the projector and move it to the location where it will be used.
 5. Position the projector so it is centered and parallel with the theater screen.
If space is limited, aim the projector slightly off-center and use lens offset to center the image on the screen.
Keep the projector lens as parallel to the screen as possible, even if significantly above the screen center. When a particularly short throw distance combines with a wide screen, you may have to forfeit some aim and stay more parallel to the screen. In such cases, some lens offset can reduce the keystone distortion.
 6. Attach the supplied safety strap to the back of the projector and fasten it to its mounting surface.

The safety strap is mandatory to prevent the projector from tipping when a lens or auxiliary lens mount is installed.

If using the optional rack stand, Christie recommends using the hold-down clamp (P/N: 116-100101-XX) in addition to the rear safety strap to firmly secure the projector's rear feet.

Adjusting the projector tilt and level

Adjust the projector tilt to fill the maximum amount of screen while minimizing keystone. Lens offset can be used to center the image in the center of the screen.



Warning! If not avoided, the following could result in death or serious injury.

- TIP HAZARD! Always use the rear safety strap to prevent the cinema projector from tipping.
- TIP HAZARD! Do not over-extend the cinema projector's feet. Make sure several threads from each foot remain engaged in the cinema projector's baseplate.



Notice. If not avoided, the following could result in property damage.

- Do not tilt the product more than ± 15 degrees.
1. Secure a safety lifting strap rated to handle the projector weight at the rear of the projector.
 2. Hoist up the projector.
 3. Center the lens parallel with the screen to make sure optimum lens performance with minimal offset.
If this position is not possible, Christie recommends relying on offset rather than extra tilt.
 4. Use a protractor to measure the degree of screen tilt and extend or retract the projector feet to match this angle.
 5. To adjust the vertical or horizontal position of the projector, extend or retract the adjustable feet on the bottom of the projector (A in the image below).

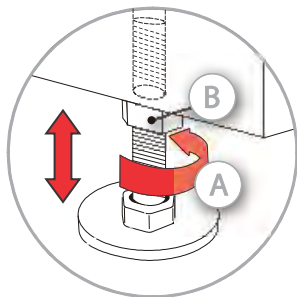

6. Once the required adjustment is made, tighten the lock nut against the bottom of the projector (B in the image in step 5).
7. For CP4420-Xe, if the vertical or horizontal position of the projector requires more adjustment than the standard feet allow, two 6-inch extension rods can be installed to the rear feet to increase the amount of available adjustment.
 - a) Prop up the rear of the projector to access and remove the two rear feet.
 - b) Add the extension rods to the standard feet.
 - c) Thread the newly extended feet back into the projector baseplate.
 - d) Adjust the feet until the required tilt is achieved.
 - e) Lock the feet in place by turning each lock nut until it fits tight against the projector.

Installing the optional touch panel control

Learn how to install the optional touch panel control (TPC) and connect the required harnesses for communication with the projector.

1. To secure the ball arm, fasten with the four screws.
Torque to 20in-lb.
2. Install the TPC arm onto the ball arm.

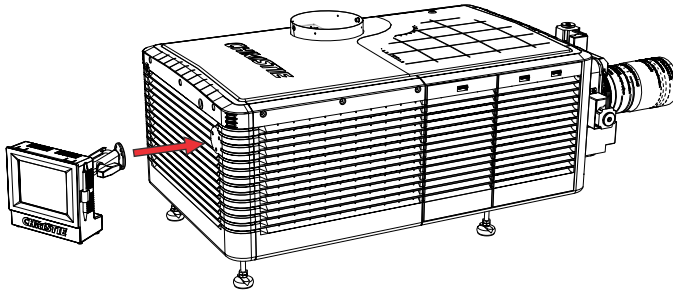

3. Install the touch screen monitor onto the TPC arm.
4. Connect the touch screen monitor communication harness.

Connecting external exhaust ducting

Connect the existing outside-venting duct to the 8-inch diameter exhaust port on the top of the projector.



Warning! If not avoided, the following could result in death or serious injury.

- At minimum, a 10-inch (25.4 cm) long strong metal duct must be installed between the product and an outside-venting duct system to prevent glass shards from exiting the duct in the event of a lamp explosion.

1. Check no obstructions or bends exist in the ducting or in the air intakes.
2. Check the vane switch at the exit duct moves freely.



Notice. If not avoided, the following could result in property damage.

- Do not remove or disable the vane switch.
3. Check the pre-installed outside-venting duct is rigid at the projector and includes a heat extractor and blower which can maintain a minimum CFM when measured at the projector exhaust opening.

When the projector is operating at less than or equal to 25°C (77°F) ambient and less than 3,000 feet (915 m), a minimum of 450 CFM is required. Above 25°C (77°F) ambient or above 3,000 feet (915 m), a minimum of 600 CFM is required.

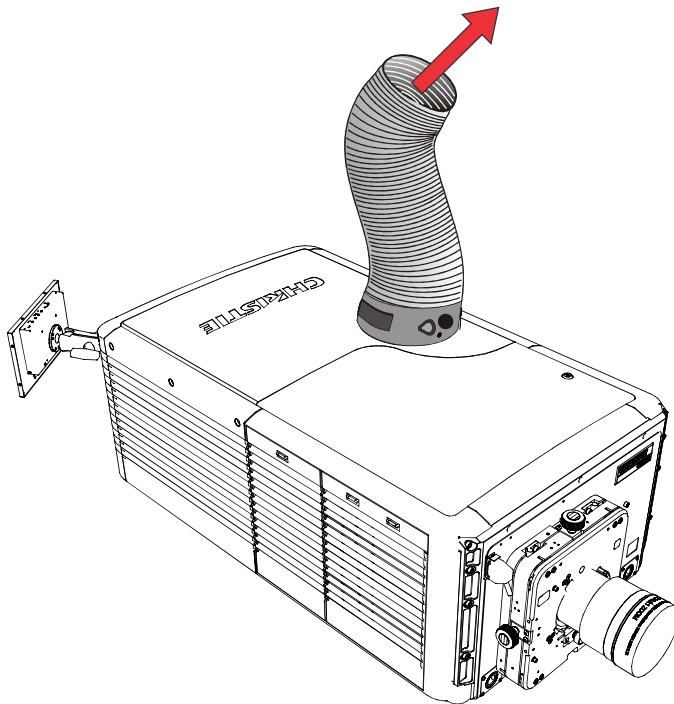

4. Determine the projector's exhaust CFM value.

Use an airflow meter to measure the ft/min at the rigid end of the open exhaust duct connecting to the projector. Take the measurement at the end of the duct without the projector connected. Use this formula to determine the CFM value for the projector: $CFM = 0.35 \times \text{Measured ft/min}$.



Notice. If not avoided, the following could result in property damage.

- Do not attempt to operate the product with inadequate airflow which can result in dangerous overheating.

Lamp type	Minimum airflow required (CFM)
2.0 kW	<ul style="list-style-type: none"> • 450 CFM at less than or equal to 25°C (77°F) ambient and less than 3,000 feet (915 m) • 600 CFM above 25°C (77°F) ambient or above 3,000 feet (915 m)
3.0 kW	<ul style="list-style-type: none"> • 450 CFM at less than or equal to 25°C (77°F) ambient and less than 3,000 feet (915 m) • 600 CFM above 25°C (77°F) ambient or above 3,000 feet (915 m)

5. Add an extractor or a booster if insufficient airflow exists.

Do not mount the extractor on the projector as this may introduce some vibration into the image.

Installing the primary lens

The lens seals the projection head, preventing contaminants from entering the main electronics area.



- Do not operate the product without a lens installed.
 - Always use a lens plug when installing or moving the product. This prevents contaminants from entering the product.
 - Keep fingers and other body parts away from the moving parts in the product. Tie back long hair, and remove jewelry and loose clothing before manually adjusting the product.
1. Verify the rear safety strap or rear hold down bracket is installed.
 2. Rotate the lens clamp to the open position.
 3. With the Up label facing up, insert the lens straight into the lens mount opening all the way back, without turning.

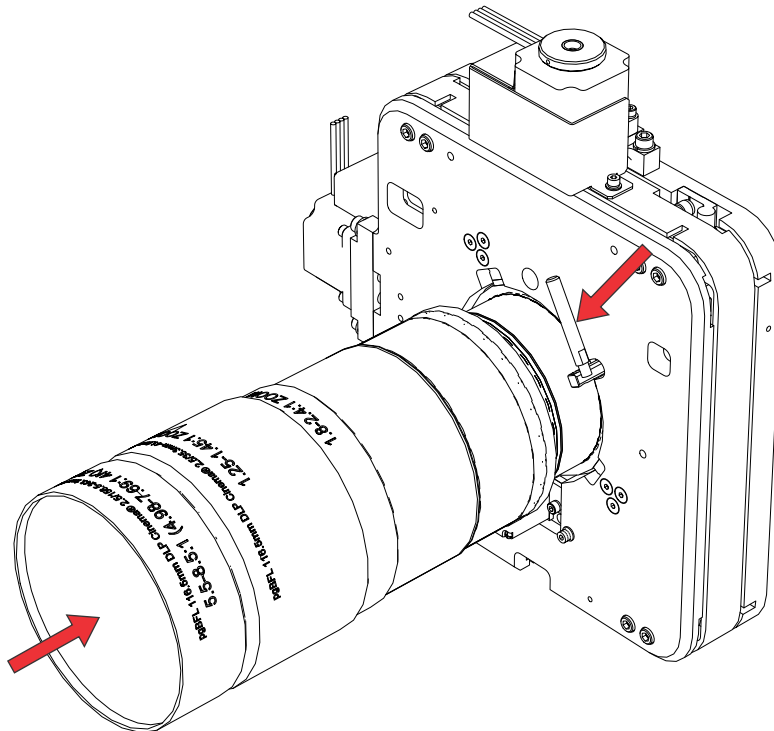

4. Move the lens clamp to the down position to lock the lens assembly.

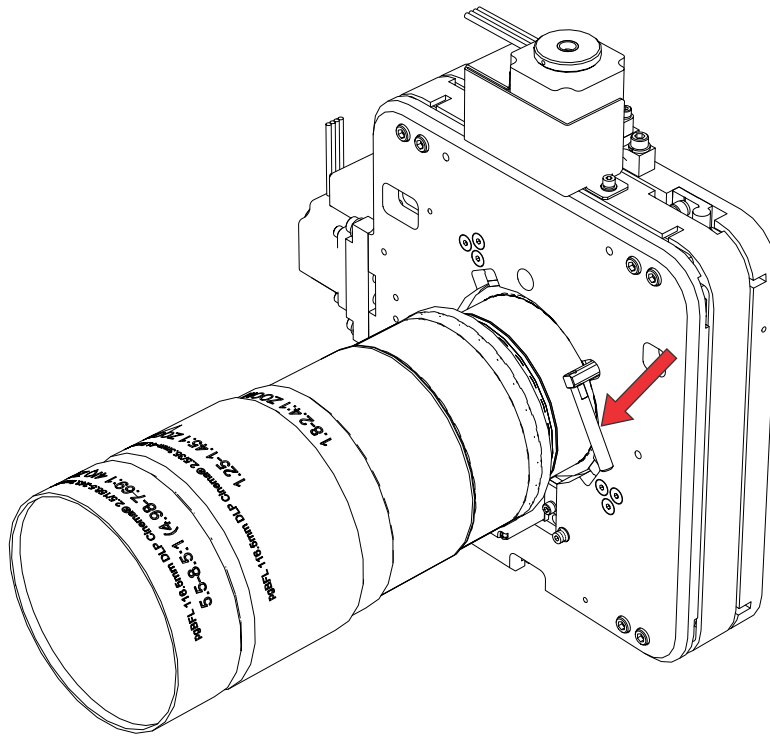

5. Remove the front lens cap.

Installing the zoom motor kit

The zoom motor kit allows for motorized adjustment of the lens.



- Do not operate the product without a lens installed.
- Always use a lens plug when installing or moving the product. This prevents contaminants from entering the product.
- Keep fingers and other body parts away from the moving parts in the product. Tie back long hair, and remove jewelry and loose clothing before manually adjusting the product.

1. Unpack the zoom motor kit.
2. Install the zoom motor mount onto the lens with a screw clamp.
3. Remove the cover from the zoom motor mount.
Keep the hardware and cover.
4. Install the zoom gear ring and, if required, an adapter onto the lens.
 - For lens 1.8-3.0, use a small adapter.
 - For lens 1.45-2.05, 2.15-3.6, 1.25-1.83:1, use a large adapter.

No other lenses need an adapter.

- For lenses: 1.6-2.4:1, 1.8-3.0:1, 2.15-3.6:1, make sure the zoom ring is against the front of motor mount.

- For lenses: 1.45-2.05:1, 1.25-1.83:1, make sure the zoom ring is against the back of motor mount.
 - For all other lenses: Leave a gap between the rotating zoom section of lens and motor mount.
5. Verify there is full travel of the gear ring and the alignment of the sensor is correct.
A small gap must exist between the gears to prevent binding. To make sure a gap exists, loosen the screws and readjust the gap. Tighten the screws when completed the adjustment.
 6. Turn the lens clamp to the Open position on the lens mount and fully insert the assembly straight into the lens mount opening without turning.
When the lens is fully inserted, it is seated properly within the lens mount and the aperture is installed correctly.
 7. Install the cover with the screws.
Make sure the cover is between the mounting tabs.
 8. Connect the harness wires.
 9. Position the lens clamp down to lock the lens assembly in place.
 10. *Calibrate the lens* (on page 52).

Installing the lamp

Learn how to install the lamp.



Warning! If not avoided, the following could result in death or serious injury.

- All procedures must be performed by Christie qualified technicians.
 - EXPLOSION HAZARD! Always wear protective safety clothing (gloves, jacket, face shield) approved by the manufacturer whenever the lamp door is open or when handling the lamp. Any local or federal specifications take precedence over Christie's protective clothing recommendations.
 - EXPLOSION HAZARD! Lamps and bare bulbs, even when packaged, may explode if dropped or mishandled.
1. Turn off the light source and cool the projector for at least 15 minutes.
 2. Turn off the breaker switch for the projector.
 3. Turn off the projector and disconnect it from AC power.
 4. Put on your protective clothing and face shield.
 5. Use the security key to open the lamp door and access the lamp cooling compartment.
Do not place heavy objects on the open lamp door.
 6. Install the anode yoke assembly.

Use the following table to determine the correct position of the anode yoke assembly:

Type	Lamp	Anode yoke position
CDXL-20	2.0 kW	Move the lamp cradle as far forward as possible (position closest to the igniter).
CDXL-30	3.0 kW	Move the lamp cradle to the rear position, which is approximately 25.5 mm (1 inch) closer to the reflector.
CDXL-30SD (short arc)		

Type	Lamp	Anode yoke position
CXL-30		

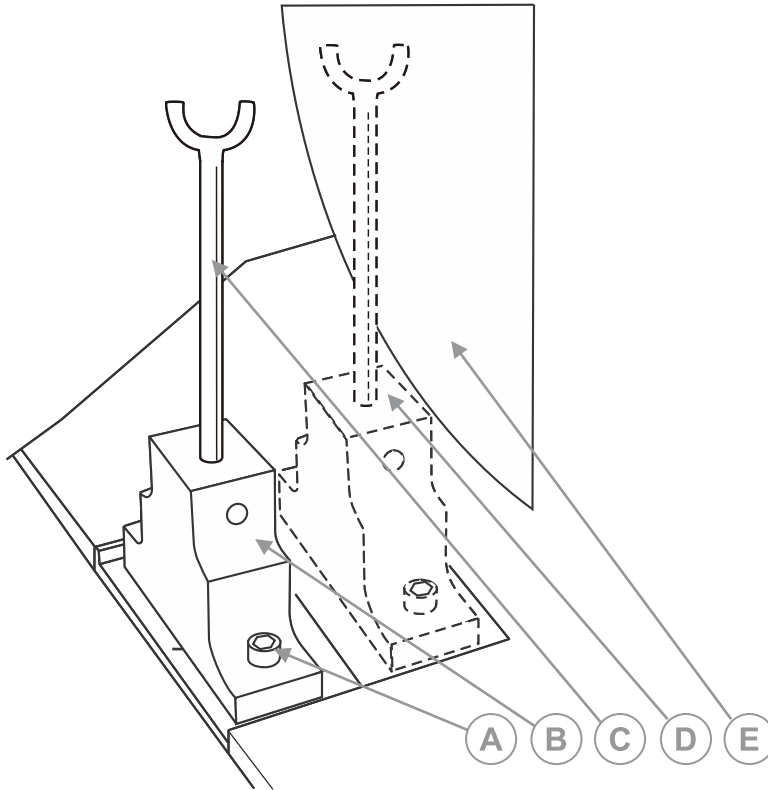

- A 5 mm hex key required
- B 2.0 kW lamp location
- C Anode yoke assembly
- D 3.0 kW lamp location
- E Reflector

7. Install the lamp.

Installing the Integrated Media Block (IMB)

Learn how to install the Integrated Media Block (IMB).

1. Release and remove the marriage ring.

The marriage ring is located on the front face of the card cage.

 - a) Locate the plunger under the security cover on the top-left of the card cage.
 - b) Pull out the plunger to release the lock.
 - c) Remove the marriage ring.
2. Install the IMB.

For information on how to install the IMB, refer to the manufacturer's product documentation.

3. Re-install the marriage ring.

Connecting the projector to AC power with a permanent connection

Learn how to connect the projector to AC power with a permanent connection.



Warning! If not avoided, the following could result in death or serious injury.

- A certified electrician must be present during installation to make sure the installation meets the local electrical code.
- SHOCK HAZARD! A dedicated, protected ground or earth wire must be installed on the product by Christie qualified technicians or electricians before it can be connected to power.
- Do not return the current through the ground or earth.
- Always connect the ground or earth first to reduce shock hazard.
- Use an appropriately sized strain relief connector with the knockout plate provided, to make sure adequate environmental sealing and to prevent the AC supply cable from accidentally being torn out or rubbing against the knockout plate.

When connecting the projector to AC power, follow all electrical codes for your location. In addition, follow these recommendations:

- Use a 30-32A, double-pole, UL-listed wall circuit breaker. It must be part of the building installation and easily accessible.
- Use 10AWG or 8AWG wiring.
 - When using 10AWG cables, the distance between the wall circuit breaker and the projector must not exceed 20 m (65.6 feet).
 - When using 8AWG cables, the distance between the wall circuit breaker and the projector must not exceed 30 m (98.4 feet).
- For North American installations, use at least 10AWG copper wires to connect the main AC supply to the projector's ground lug.

Follow these steps to connect the projector to AC power with a permanent connection:

1. On the bottom of the projector in the front-right corner, loosen the two screws and slide the plate forward to expose the terminal block.

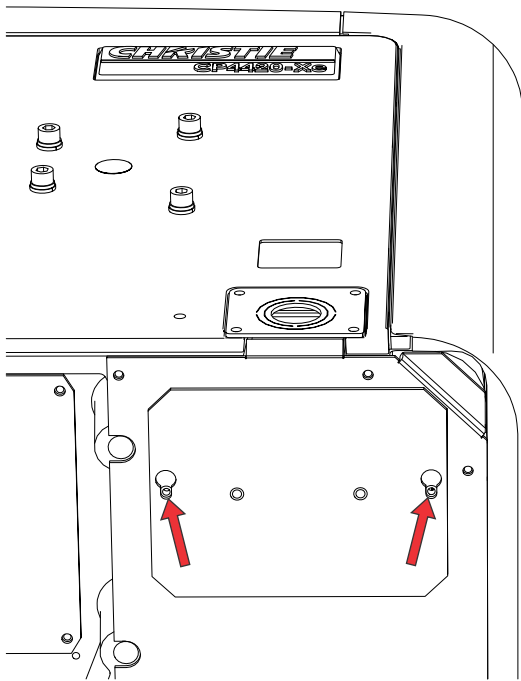

2. Remove the knockout plate located in the bottom-right corner of the front bezel.

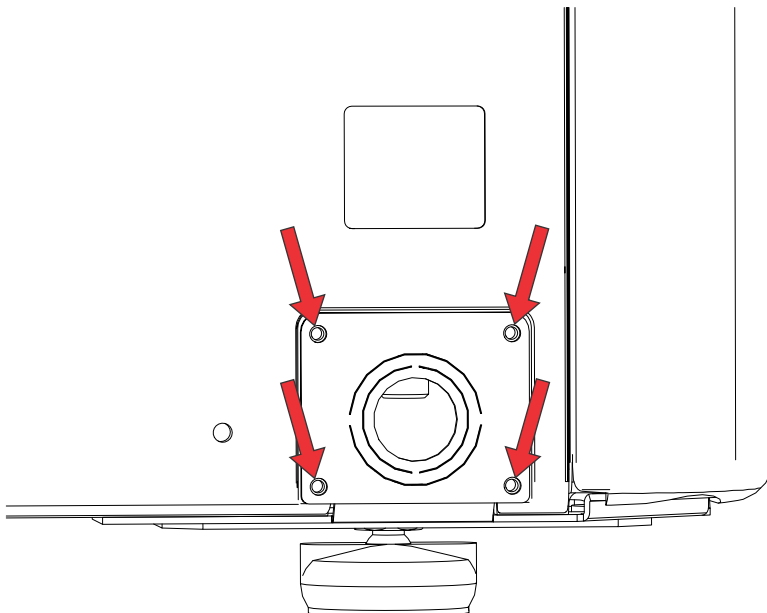

The AC supply is routed to the terminal block through a strain relief mounted on this knockout plate.

3. Connect the AC power cables to the terminal block, beginning with the ground lead first.
Use an appropriately sized strain relief connector with the knockout plate provided to make sure adequate environmental sealing and to prevent the cables from wear and accidentally being torn out.



If required, use a 90° strain relief connector to route the power cable downward.

4. Connect the AC supply to the terminal block.
Connect the ground first to reduce the risk of electrical shock.

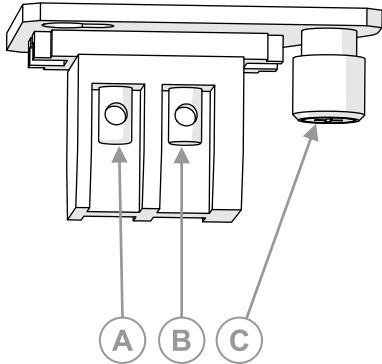

A	N
B	L
C	Ground

5. Replace the knockout plate and the bottom access panel over the terminal block.

Connecting the projector to AC power with a pluggable type B connection

Learn how to connect the projector to AC power with a pluggable type B connection.

When connecting the projector to AC power, follow all electrical codes for your location. In addition, follow these recommendations:

- Use a 30-32A, double-pole, UL-listed wall circuit breaker. It must be part of the building installation and easily accessible.
- Use 10AWG or 8AWG wiring.
 - When using 10AWG cables, the distance between the wall circuit breaker and the projector must not exceed 20 m (65.6 feet).
 - When using 8AWG cables, the distance between the wall circuit breaker and the projector must not exceed 30 m (98.4 feet).
- The socket-outlet must be installed near the equipment and must be easily accessible. The plug can be used as the device disconnect.

Follow these steps to connect the projector to AC power with a pluggable type B connection:

1. On the bottom of the projector in the front right corner, loosen the two screws and slide the plate forward to expose the terminal block.
2. Remove the four screws located in the bottom right corner of the front bezel.
3. Connect AC power to the terminal block, beginning with the ground lead first. Tighten the screws securely.

4. Replace the knockout plate and the bottom access panel over the terminal block.

Connecting the projector to an uninterruptible power supply (optional)

An uninterruptible power supply (UPS) allows the projector head electronics to remain operable during a brief power failure.

1. Turn off the projector and disconnect it from AC power.
2. Make sure the main breaker is off.
3. Disconnect the low voltage power supply (LVPS) from main power and connect it to the UPS input socket.
4. Connect the UPS to the main power socket.

Turning on the projector for the first time

Learn how to turn on the projector for the first time. Use this procedure to ensure successful communication with input devices and to align the lamp.

1. Assign the projector a unique IP address:
 - a) In the left navigation menu, select **Service Setup > Network Settings**.
 - b) On the Ethernet tab, either **Obtain the IP address automatically** or enter the IP address for the projector in the **IP Address** field.
2. Enter the lamp information.
 - a) In the left navigation menu, select **Lamp Settings > Lamp History**.
 - b) Select **+ New Lamp**.
 - c) Complete the fields in the **New Lamp** dialog.
 - d) Select **Add**.
3. Select and hold the Power button to turn on the projector.
4. Complete a LampLOC™ alignment on the new lamp.
 - a) In the left navigation menu, select **Lamp Settings > LampLOC**.
 - b) Select **Auto Align**.

Disposing of the product packaging

Once the product has been installed and set up, Christie recommends reusing or recycling the product packaging according to your local regulations.

Video Input panel

The Video Input panel, located on the projector side input panel (operator side), has a variety of ports that can supply alternative video content to the projector.

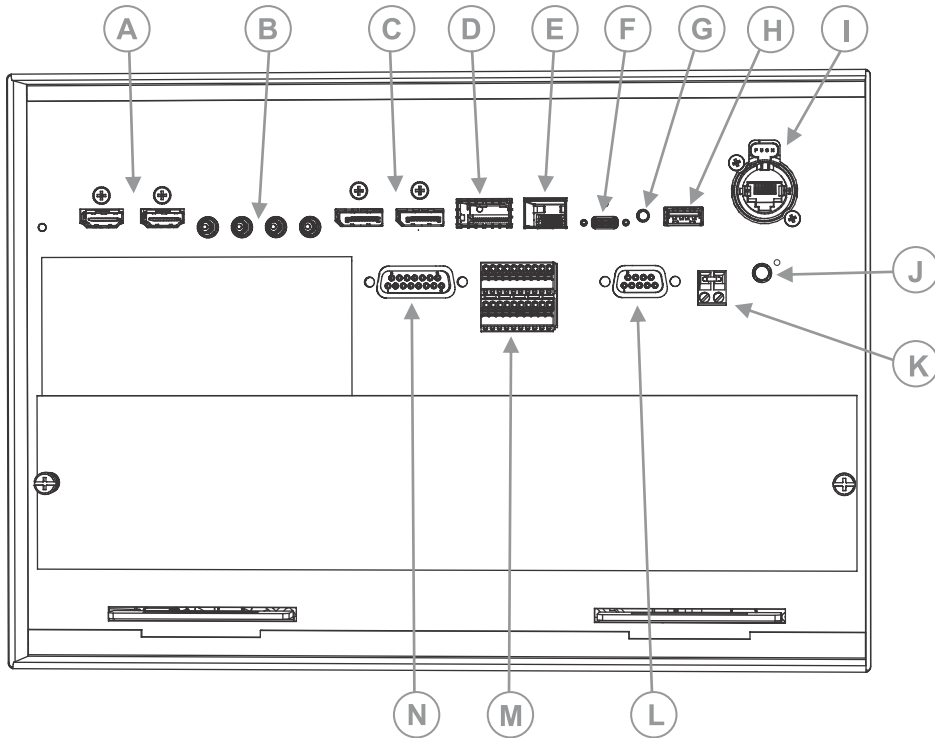

ID	Port	Description
A	HDMI input 1 and HDMI input 2	Type A connector Accepts digital video data from HDMI v2.0 input supporting EDID 1.3 with HDCP v1.4 and 2.2 support.
B	SDI input 1, SDI input 2, SDI input 3, and SDI input 4	75 ohm Micro-BNC Connector Multi-Rate SDI in accordance with SMPTE ST 259 (270 Mb/s), ST 292-1 (1.5 Gb/s), ST 424 (3.0 Gb/s), ST 2081-1 (6 Gb/s) and ST 2082-1 (12 Gb/s)
C	DisplayPort (DP1 and DP2)	Accepts digital video data from DisplayPort 1.2 input supporting EDID 1.3 with HDCP 1.3 support.
D	Christie Link port	Not used.
E	Software-Defined Video over Ethernet (SDVoE) port	Not used.
F	USB-C port	Connects the projector touch panel.

ID	Port	Description
G	Recessed button	Select the button to transition the projector from Standby mode to Power ON mode.
H	USB port	Connects to external memory device for import and export of projector software, configuration files, and status information.
I	Management port	Connects to the local network and can send CineLife+ serial commands and used for Remote UI access.
J	Marriage button	Used during the Integrated Media Block (IMB) marriage setup process. <ul style="list-style-type: none"> • Select and hold the button for 5 seconds to display the IP address and status information. • Select and hold the button for 30 seconds to reset the IP address to the default address. The marriage status LED indicator is located to the right of the Marriage button. In full power mode, a green LED indicates the projector is properly married and encrypted content can be displayed. A red LED indicates marriage is broken and encrypted content cannot be displayed.
K	Fire alarm connection	Connects to the Theater Fire Management system for automatic shut down in emergency situations.
L	RS232 communication port	Not used.
M	GPIO port	Connects the projector to external automation or automation devices.
N	3D sync connector	Connects the projector to 3D devices.

HDMI video source

For the projector to accept digital video data from HDMI sources, plug the HDMI source directly into the Video Input panel.

The input configurations listed below are supported.

Input configuration	Description
Single-input	Accepts connection of one HDMI cable. Supports both 2D and 3D frame-packed, top and bottom. In this configuration, the HDMI input supplies the entire video raster.
Dual-input	Enables connection of two HDMI cables in support of 3D LR, where HDMI Input 1 = left eye and HDMI Input 2 = right eye.

HDMI video formats

The following image formats are supported by the two HDMI inputs.



Fractional 1/1.001 frame rates, 1920 x 1080 (HD), and 3840 x 2160 (UHD) formats are also supported.

Single-input 2D 2K and 4K HDMI 2.0 image formats

Each HDMI input supports the following single-input (one cable) 2D 2K and 4K HDMI 2.0 image formats.

	Format	Cables	Frame rate (Hz)	Sampling	Bit-depth
2K	2048x1080	1	24, 25, 30, 50, 60, 120	Y'C _B C _R /RGB/4:4:4 Y'C _B C _R /4:2:2	8/10/12 bpc
4K	4096x2160	1	24, 25, 30	Y'C _B C _R /RGB/4:4:4 Y'C _B C _R /4:2:2	8/10/12 bpc
	4096x2160	1	50, 60	Y'C _B C _R /RGB/4:4:4	8 bpc
	4096x2160	1	50, 60	Y'C _B C _R /4:2:2	8/10/12 bpc

Single-input 2D HD HDMI 2.0 image formats

Each HDMI input supports the following single-input (one cable) 2D HD HDMI 2.0 image formats.

	Format	Cables	Frame rate (Hz)	Sampling	Bit-depth	Notes
HD	1280x720	1	24, 25, 30, 50, 60	Y'C _B C _R /RGB/4:4:4 Y'C _B C _R /4:2:2	8/10/12 bpc	-
	1920x1080i	1	25, 30	Y'C _B C _R /RGB/4:4:4 Y'C _B C _R /4:2:2	8/10/12 bpc	2048x1080 interlaced (50/60 Hz field rate)

Single-input 2D HDMI 2.0 PC image formats

Each HDMI input supports the following single-input 2D HDMI 2.0 PC image formats.

	Format	Cables	Frame rate (Hz)	Sampling	Bit-depth
PC	1280x800	1	60	RGB	8 bpc
	1280x960	1	60	RGB	8 bpc
	1280x1024	1	60	RGB	8 bpc
	1440x900	1	60	RGB	8 bpc
	1680x1050	1	60	RGB	8 bpc
	1600x1200	1	60	RGB	8 bpc
	2048x1200	1	60	RGB	8 bpc

Single-input 3D 2K/HD HDMI 2.0 image formats

Each HDMI input supports the following single-input (one cable) 3D 2K/HD HDMI 2.0 image formats.

	Format	Cables	Frame rate (Hz)	Sampling	Bit-depth	Notes
3D	1280x720	1	50, 60	Y'C _B C _R /RGB/ 4:4:4 Y'C _B C _R /4:2:2	8/10/12 bpc	Frame-packing/ top-and-bottom
	2048x1080	1	24, 25, 30, 50, 60	Y'C _B C _R /RGB/ 4:4:4 Y'C _B C _R /4:2:2	8/10/12 bpc	Frame-packing

Dual-input 3D 2K/4K HDMI 2.0 image formats

The following dual-input 3D 2K/4K HDMI 2.0 image formats are supported, where HDMI Input 1 = left eye and HDMI Input 2 = right eye. Frame rate is expressed per eye in the following table.

	Format	Cables	Frame rate (Hz)	Sampling	Bit-depth
2K	2048x1080	2	24, 25, 30, 50, 60	Y'C _B C _R /RGB/4:4:4 Y'C _B C _R /4:2:2	8/10/12 bpc
4K	4096x2160	2	24, 25, 30	Y'C _B C _R /RGB/4:4:4 Y'C _B C _R /4:2:2	8/10/12 bpc
	4096x2160	2	50, 60	Y'C _B C _R /RGB/4:4:4	8 bpc
	4096x2160	2	50, 60	Y'C _B C _R /4:2:2	8/10/12 bpc

SDI video source

For the projector to accept digital video data from 12G, 6G, 3G, or HD/SD SDI video source, plug the source directly into the Video Input panel.

The input configurations listed below are supported.

Input configuration	Description
Single-link	Accepts connection of 12G, 6G, 3G, and HD/SD SDI input standards.
Dual-link	Accepts connection of dual-link 6G, 3G, and HD SDI input standards.
Quad-link	Accepts connection of quad-link 6G or 3G SDI input standards.

SDI video formats

Each of the SDI inputs supports the following single-Link 2D SD and HD image formats, single-link 2D HD and UHD/4K image formats, dual-link 2D SDI image formats, and quad-link 2D image formats.



Fractional 1/1.001 frame rates, 1920 x 1080 (HD), and 3840 x 2160 (UHD) formats are also supported.

Single-link 2D: SD, 720p and 1080i image formats

The following SDI inputs support the following single-link (one cable) 2D SD, 720p, and 1080i image formats.

	Format	Cables	Frame rate (Hz)	Sampling	Bit-depth	Notes
SD	720x480	1	30	Y'C _B C _R /4:2:2	10 bpc	SD interlaced component at 270 Mb/s (ST 259 level C) interlaced (60 Hz field rate)
	720x576	1	25	Y'C _B C _R /4:2:2	10 bpc	SD interlaced component at 270 Mb/s (ST 259 level C) interlaced (50 Hz field rate)
HD	1280x720	1	24, 25, 30, 50, 60	Y'C _B C _R /4:2:2	10 bpc	HD 720p Y'C _B C _R component at 1.5 Gb/s (ST 292-1)
	1280x720	1	24, 25, 30, 50, 60	Y'C _B C _R /4:4:4(4)	10 bpc	HD 720p Y'C _B C _R /RGB component at 3.0 Gb/s (ST 425-1) level A
2K	2048x1080	1	25, 30	Y'C _B C _R /4:2:2	10 bpc	HD 1080i component at 1.5 Gb/s (ST 292-1) interlaced (50/60 Hz field rate)

Single-link 2D: 2K and 4K HD/UHD

The following SDI inputs support the following single-link (one cable) 2D HD and UHD/4K image formats.

	Format	Cables	Frame rate (Hz)	Sampling	Bit-depth	Notes
2K	2048X1080	1	24, 25, 30	Y'C _B C _R /4:2:2	10 bpc	HD 1080p component at 1.5 Gb/s (ST 292-1)
	2048X1080	1	48, 50, 60	Y'C _B C _R /4:2:2	10 bpc	HD 1080p component at

Format	Cables	Frame rate (Hz)	Sampling	Bit-depth	Notes	
					3.0 Gb/s (ST 425-1) level A	
2048X1080	1	24, 25, 30	Y'C _B C _R /RGB/4:4:4(4)	12 bpc	HD 1080p Y'C _B C _R /RGB component at 3.0 Gb/s (ST 425-1) level A	
2048X1080	1	24, 25, 30	Y'C _B C _R /4:2:2(4)	12 bpc	HD 1080p Y'C _B C _R component at 3.0 Gb/s (ST 425-1) level A	
2048X1080	1	48, 50, 60	Y'C _B C _R /RGB/4:4:4(4)	10 bpc	HD 1080p Y'C _B C _R /RGB component at 6.0 Gb/s (ST 2081-10) mode 2 structure II	
2048X1080	1	48, 50, 60	Y'C _B C _R /RGB/4:4:4	12 bpc	HD 1080p Y'C _B C _R /RGB component at 6.0 Gb/s (ST 2081-10) mode 2 structure III	
4K	4096X2160	1	48, 50, 60	Y'C _B C _R /4:2:2	10 bpc	2160p Y'C _B C _R component at 6.0 Gb/s (ST 2081-10) mode 1 structure 1
	4096X2160	1	24, 25, 30	Y'C _B C _R /RGB/4:4:4(4)	10 bpc	2160p Y'C _B C _R /RGB component at 12.0 Gb/s (ST 2082-10) mode 1 structure 2
	4096X2160	1	24, 25, 30	Y'C _B C _R /RGB/4:4:4	12 bpc	2160p Y'C _B C _R /RGB component at 12.0 Gb/s (ST 2082-10) mode 1 structure 3

Format	Cables	Frame rate (Hz)	Sampling	Bit-depth	Notes
4096X2160	1	24, 25, 30	Y'C _B C _R /4:2:2(4)	12 bpc	2160p Y'C _B C _R component at 12.0 Gb/s (ST 2082-10) mode 1 structure 4

Dual-link 2D: 2K and 4K HD/UHD

The following dual-link (two cable) 2D HD and UHD/4K image formats are supported. Dual-link SDI is a fixed configuration.

- SDI 1 = link 1 of input 1
- SDI 2 = link 2 of input 1
- SDI 3 = link 1 of input 2
- SDI 4 = link 2 of input 2



Fractional 1/1.001 frame rates, 1920x1080, and 3840x2160 (UHD) formats are also supported.

Format	Cables	Frame rate (Hz)	Sampling	Bit-depth	Notes	
2K	2048x1080	2	48, 50, 60	Y'C _B C _R /RGB/4:4:4(4)	10 bpc	Y'C _B C _R /RGB component at dual-link 3 Gb/s (ST 425-3) level A structure II
	2048x1080	2	48, 50, 60	Y'C _B C _R /RGB/4:4:4	12 bpc	Y'C _B C _R /RGB component at dual-link 3 Gb/s (ST 425-3) level A structure III
	2048x1080	2	48, 50, 60	Y'C _B C _R /4:2:2	12 bpc	Y'C _B C _R component at dual-link 3 Gb/s (ST 425-3) level A structure IV
	2048x1080	2	48, 50, 60	Y'C _B C _R /4:2:2:4	12 bpc	Y'C _B C _R component at dual-link 3 Gb/s (ST 425-3) level A structure IV
4K	4096X2160	2	48, 50, 60	Y'C _B C _R /4:2:2	10 bpc	Y'C _B C _R component at

Format	Cables	Frame rate (Hz)	Sampling	Bit-depth	Notes
					dual-link 6 Gb/s (ST 2081-11) mode 1
4096X2160	2	24, 25, 30	Y'C _B C _R /RGB/4:4:4(4)	10 bpc	Y'C _B C _R /RGB component at dual-link 6 Gb/s (ST 2081-11) mode 1
4096X2160	2	24, 25, 30	Y'C _B C _R /RGB/4:4:4	12 bpc	Y'C _B C _R /RGB component at dual-link 6 Gb/s (ST 2081-11) mode 1
4096X2160	2	24, 25, 30	Y'C _B C _R /4:2:2	12 bpc	Y'C _B C _R component at dual-link 6 Gb/s (ST 2081-11) mode 1
4096X2160	2	24, 25, 30	Y'C _B C _R /4:2:2:4	12 bpc	Y'C _B C _R component at dual-link 6 Gb/s (ST 2081-11) mode 1

Quad-link 2D: 4K UHD

The following quad-link (four cable) 2D image formats are supported. The quad-link SDI is a fixed configuration.

- SDI 1 = link 1
- SDI 2 = link 2
- SDI 3 = link 3
- SDI 4 = link 4



Fractional 1/1.001 frame rates and 3840x2160 (UHD) formats are also supported.

Format	Cables	Frame rate (Hz)	Sampling	Bit-depth	Notes
4K	4	24, 25, 30	Y'C _B C _R /RGB/4:4:4(4)	10 bpc	Y'C _B C _R /RGB component at quad-link 3 Gb/s (ST

Format	Cables	Frame rate (Hz)	Sampling	Bit-depth	Notes
					425-5) level A structure 2
4096x2160	4	24, 25, 30	Y'C _B C _R /RGB/4:4:4	12 bpc	Y'C _B C _R /RGB component at quad-link 3 Gb/s (ST 425-5) level A structure 3
4096x2160	4	24, 25, 30	Y'C _B C _R /4:2:2(4)	12 bpc	Y'C _B C _R component at quad-link 3 Gb/s (ST 425-5) level A structure 4
4096x2160	4	24, 25, 30	Y'C _B C _R /4:2:2	12 bpc	Y'C _B C _R component at quad-link 3 Gb/s (ST 425-5) level A structure 4
4096x2160	4	48, 50, 60	Y'C _B C _R /RGB/4:4:4(4)	10 bpc	Y'C _B C _R /RGB component at quad-link 6 Gb/s (ST 2081-12) mode 2 structure III
4096x2160	4	48, 50, 60	Y'C _B C _R /RGB/4:4:4	12 bpc	Y'C _B C _R /RGB component at quad-link 6 Gb/s (ST 2081-12) mode 2 structure III
4096x2160	4	48, 50, 60	Y'C _B C _R /4:2:2:4	12 bpc	Y'C _B C _R component at quad-link 6 Gb/s (ST 2081-12) mode 2 structure IV

DisplayPort video source

For the projector to accept digital video data, plug the DisplayPort source directly into the Video Input panel.

The input configurations listed below are supported.

Input configuration	Description
Single-input	Enables connection of one DisplayPort cable. Supports both 2D and 3D frame sequential transmission format. In this configuration the DisplayPort input supplies the entire video raster.
Dual-input	Enables connection of two DisplayPort cables. Supports both 2D and 3D frame sequential transmission format.

DisplayPort video formats

The following image formats are supported by the DisplayPort inputs.



Frame rates also include fractional 1/1.001 frame rates.

Single-input DisplayPort 1.2 image formats

The following single-input DisplayPort 1.2 image formats are supported on each of the DP 1.2 inputs.

	Format	Cables	Frame rate (Hz)	Sampling	Bit-depth
HD	1280x720	1	24, 25, 30, 50, 60, 120	Y'C _B C _R /RGB/4:4:4	8/10/12bpc
	1920x1080	1	24, 25, 30, 50, 60, 120	Y'C _B C _R /RGB/4:4:4	8/10/12bpc
	2048x1080	1	24, 25, 30, 50, 60, 120	Y'C _B C _R /RGB/4:4:4	8/10/12bpc
4K	3840x2160	1	24, 25, 30, 50, 60	Y'C _B C _R /RGB/4:4:4	8/10bpc
	4096x2160	1	24, 25, 30, 50, 60	Y'C _B C _R /RGB/4:4:4	8/10bpc

Single-input 3D DisplayPort 1.2 image formats

The following single-input 3D DisplayPort image formats are supported in frame sequential transmission format. Frame rate is expressed per eye in the following table.

	Format	Cables	Frame rate (Hz)	Sampling	Bit-depth
HD	1280x720	1	24, 25, 30, 50, 60	Y'C _B C _R /RGB/4:4:4	8/10/12bpc
	1920x1080	1	24, 25, 30, 50, 60	Y'C _B C _R /RGB/4:4:4	8/10/12bpc
	2048x1080	1	24, 25, 30, 50, 60	Y'C _B C _R /RGB/4:4:4	8/10/12bpc
4K	3840x2160	1	24, 25, 30	Y'C _B C _R /RGB/4:4:4	8/10bpc
	4096x2160	1	24, 25, 30	Y'C _B C _R /RGB/4:4:4	8/10bpc

Dual-input 3D DisplayPort 1.2 image formats

The following dual-input 3D DisplayPort 1.2 image formats are supported. Frame rate is expressed per eye in the following table.

	Format	Cables	Frame rate (Hz)	Sampling	Bit-depth
HD	1280x720	2	24, 25, 30, 50, 60	Y'C'B'C'R/RGB/4:4:4	8/10/12bpc
	1920x1080	2	24, 25, 30, 50, 60	Y'C'B'C'R/RGB/4:4:4	8/10/12bpc
	2048x1080	2	24, 25, 30, 50, 60	Y'C'B'C'R/RGB/4:4:4	8/10/12bpc
4K	3840x2160	2	24, 25, 30, 50, 60	Y'C'B'C'R/RGB/4:4:4	8/10bpc
	4096x2160	2	24, 25, 30, 50, 60	Y'C'B'C'R/RGB/4:4:4	8/10bpc

Single-link DisplayPort PC image formats

The following single-link DisplayPort PC image formats are supported.

	Format	Cables	Frame rate (Hz)	Sampling	Bit-depth
PC	1280x800	1	60	RGB	8bpc
	1280x960	1	60	RGB	8bpc
	1280x1024	1	60	RGB	8bpc
	1440x900	1	60	RGB	8bpc
	1680x1050	1	60	RGB	8bpc
	1600x1200	1	60	RGB	8bpc
	1920x1200	1	60	RGB	8bpc

Integrated Media Block (IMB) video source

Connect a compatible device to either the S2 or S4 interface of the projector to send digital video data from an Integrated Media Block (IMB) to the projector.

The IMB input configurations listed below are supported.

Input configuration	Description
S2 or S4 IMB	Enables connection of MPEG-2 video formats.
	Enables connection of MPEG-2 MXF interop video formats.
	Enables connection of SMPTE-compatible 2D and 3D video formats

Contact Christie Technical Support to learn which S2 and S4 IMB devices are compatible with Christie projectors.

Series 2 Integrated Media Block (IMB) video formats

S2 Integrated Media Block (IMB) video format support is determined by the IMB make and model. Refer to the associated IMB documentation to understand which of the following video signals are supported.

All MPEG-2 content is converted in the media block to RGB 4:4:4 8-bit before play out.

MPEG image formats

Format	Resolution	Max frame rate 2D	Max frame rate 3D	Min frame rate	Bit-depth
VGA	640x480	120.0	120.0	23.0	8-bits
4CIF	704x576	120.0	120.0	23.0	8-bits
525 SD	720x480	120.0	120.0	23.0	8-bits
625 SD	720x568	120.0	120.0	23.0	8-bits
XGA	1024x768	79.6	79.6	23.0	8-bits
720p HD	1280x720	68.0	68.0	23.0	8-bits
4VGA	1280x960	51.0	51.0	23.0	8-bits
SXGA	1280x1024	47.8	N/A	23.0	8-bits
525 16SIF	1408x960	46.3	N/A	23.0	8-bits
16CIF	1408x1152	38.6	N/A	23.0	8-bits
4SVGA	1600x1200	32.6	N/A	23.0	8-bits
1080 HD	2048x1080	30.0	N/A	23.0	8-bits

MPEG-2 MXF interop 2D image formats

Format	Resolution	Max frame rate 2D	Max frame rate 3D	Min frame rate	Bit-depth
VGA	640x480	120.0	120.0	23.0	8-bits
525 4SIF	704x480	120.0	120.0	23.0	8-bits
525 SD	720x480	120.0	120.0	23.0	8-bits
4CIF	704x576	120.0	120.0	23.0	8-bits
625 SD	800x600	120.0	120.0	23.0	8-bits
SVGA	1024x768	79.6	79.6	23.0	8-bits
XGA	1024x768	79.6	79.6	23.0	8-bits
720p HD	1280x720	68.0	68.0	23.0	8-bits
4VGA	1280x960	51.0	51.0	23.0	8-bits
SXGA	1280x1024	47.8	N/A	23.0	8-bits
525 16SIF	1408x960	46.3	N/A	23.0	8-bits

Format	Resolution	Max frame rate 2D	Max frame rate 3D	Min frame rate	Bit-depth
16CIF	1408x1152	38.6	N/A	23.0	8-bits
4SVGA	1600x1200	32.6	N/A	23.0	8-bits
1080 HD	2048x1080	30.0	N/A	23.0	8-bits

SMPTTE-compatible 2D (JPEG 2000) cinema image formats

Specification	Resolution	Frame rate	Color format	Bit-depth
SMPTTE 428-1-2019	2048x1080	24.0	X'Y'Z' (4:4:4)	12-bits
SMPTTE 428-11-2013	2048x1080	25.0	X'Y'Z' (4:4:4)	12-bits
SMPTTE 428-11-2013	2048x1080	30.0	X'Y'Z' (4:4:4)	12-bits
SMPTTE 428-1-2019	2048x1080	48.0	X'Y'Z' (4:4:4)	12-bits
SMPTTE 428-11-2013	2048x1080	50.0	X'Y'Z' (4:4:4)	12-bits
SMPTTE 428-11-2013	2048x1080	60.0	X'Y'Z' (4:4:4)	12-bits
SMPTTE 428-1-2019	4096x2160	24.0	X'Y'Z' (4:4:4)	12-bits
SMPTTE 428-11-2013	4096x2160	25.0	X'Y'Z' (4:4:4)	12-bits
SMPTTE 428-11-2013	4096x2160	30.0	X'Y'Z' (4:4:4)	12-bits

SMPTTE-compatible 3D (JPEG 2000) cinema image formats

Specification	Resolution	Frame rate (per eye)	Color format	Bit-depth
SMPTTE 428-1-2019	2048x1080	24.0x2	X'Y'Z' (4:4:4)	12-bits
SMPTTE 428-1-2019	2048x1080	48.0x2	X'Y'Z' (4:4:4)	12-bits
SMPTTE 428-11-2013	2048x1080	60.0x2	X'Y'Z' (4:4:4)	12-bits

Series 4 Integrated Media Block (IMB) video formats

S4 Integrated Media Block (IMB) video format support is determined by the IMB make and model. Refer to the associated IMB documentation to understand which of the following video signals are supported.

All MPEG-2 content is converted in the media block to RGB 4:4:4 8-bit before play out.

MPEG image formats

Format	Resolution	Max frame rate 2D	Max frame rate 3D	Min frame rate	Bit depth
VGA	640x480	120.0	120.0	23.0	8-bits
525 4SIF	704x480	120.0	120.0	23.0	8-bits

Format	Resolution	Max frame rate 2D	Max frame rate 3D	Min frame rate	Bit depth
525 SD	720x480	120.0	120.0	23.0	8-bits
4CIF	704x576	120.0	120.0	23.0	8-bits
625 SD	800x600	120.0	120.0	23.0	8-bits
SVGA	1024x768	79.6	79.6	23.0	8-bits
XGA	1024x768	79.6	79.6	23.0	8-bits
720p HD	1280x720	68.0	68.0	23.0	8-bits
4VGA	1280x960	51.0	51.0	23.0	8-bits
SXGA	1280x1024	47.8	N/A	23.0	8-bits
525 16SIF	1408x960	46.3	N/A	23.0	8-bits
16CIF	1408x1152	38.6	N/A	23.0	8-bits
4SVGA	1600x1200	32.6	N/A	23.0	8-bits
1080 HD	2048x1080	30.0	N/A	23.0	8-bits

MPEG-2 MXF interop 2D image formats

Format	Resolution	Max frame rate 2D	Max frame rate 3D	Min frame rate	Bit depth
VGA	640x480	120.0	120.0	23.0	8-bits
525 4SIF	704x480	120.0	120.0	23.0	8-bits
525 SD	720x480	120.0	120.0	23.0	8-bits
625 SD	720x568	120.0	120.0	23.0	8-bits
4CIF	704x576	120.0	120.0	23.0	8-bits
XGA	1024x768	79.6	79.6	23.0	8-bits
720p HD	1280x720	68.0	68.0	23.0	8-bits
4VGA	1280x960	51.0	51.0	23.0	8-bits
SXGA	1280x1024	47.8	N/A	23.0	8-bits
525 16SIF	1408x960	46.3	N/A	23.0	8-bits
16CIF	1408x1152	38.6	N/A	23.0	8-bits
4SVGA	1600x1200	32.6	N/A	23.0	8-bits
1080 HD	2048x1080	30.0	N/A	23.0	8-bits

SMPTÉ-compatible 2D (JPEG 2000) cinema image formats

Specification	Resolution	Frame rate	Color format	Bit depth
SMPTÉ 428-1-2019	2048x1080	24.0	X'Y'Z' (4:4:4)	12-bits

Specification	Resolution	Frame rate	Color format	Bit depth
SMPTE 428-11-2013	2048x1080	25.0	X'Y'Z' (4:4:4)	12-bits
SMPTE 428-11-2013	2048x1080	30.0	X'Y'Z' (4:4:4)	12-bits
SMPTE 428-1-2019	2048x1080	48.0	X'Y'Z' (4:4:4)	12-bits
SMPTE 428-11-2013	2048x1080	50.0	X'Y'Z' (4:4:4)	12-bits
SMPTE 428-11-2013	2048x1080	60.0	X'Y'Z' (4:4:4)	12-bits
SMPTE 428-11-2013	2048x1080	96.0	X'Y'Z' (4:4:4)	12-bits
SMPTE 428-11-2013	2048x1080	100.0	X'Y'Z' (4:4:4)	12-bits
SMPTE 428-11-2013	2048x1080	120.00	X'Y'Z' (4:4:4)	12-bits
SMPTE 428-1-2019	4096x2160	24.0	X'Y'Z' (4:4:4)	12-bits
SMPTE 428-11-2013	4096x2160	25.0	X'Y'Z' (4:4:4)	12-bits
SMPTE 428-11-2013	4096x2160	30.0	X'Y'Z' (4:4:4)	12-bits
SMPTE 2048-1-2011 Am1:2016	4096x2160	48	X'Y'Z' (4:4:4)	12-bits
SMPTE 2048-1-2011 Am1:2016	4096x2160	50	X'Y'Z' (4:4:4)	12-bits
SMPTE 2048-1-2011 Am1:2016	4096x2160	60	X'Y'Z' (4:4:4)	12-bits
SMPTE 2048-1-2011 Am1:2016	4096x2160	96	X'Y'Z' (4:4:4)	12-bits
SMPTE 2048-1-2011 Am1:2016	4096x2160	100	X'Y'Z' (4:4:4)	12-bits
SMPTE 2048-1-2011 Am1:2016	4096x2160	120	X'Y'Z' (4:4:4)	12-bits

SMPTE-compatible 3D (JPEG 2000) cinema image formats

Specification	Resolution	Frame rate (per eye)	Color format	Bit depth
SMPTE 428-1-2019	2048x1080	24.0x2	X'Y'Z' (4:4:4)	12-bits
SMPTE 428-11-2013	2048x1080	25.0x2	X'Y'Z' (4:4:4)	12-bits
SMPTE 428-11-2013	2048x1080	30.0x2	X'Y'Z' (4:4:4)	12-bits
SMPTE 428-1-2019	2048x1080	48.0x2	X'Y'Z' (4:4:4)	12-bits
SMPTE 428-11-2013	2048x1080	50.0x2	X'Y'Z' (4:4:4)	12-bits
SMPTE 428-11-2013	2048x1080	60.0x2	X'Y'Z' (4:4:4)	12-bits
SMPTE 428-1-2019	4096x2160	24.0x2	X'Y'Z' (4:4:4)	12-bits
SMPTE 428-11-2013	4096x2160	25.0x2	X'Y'Z' (4:4:4)	12-bits
SMPTE 428-11-2013	4096x2160	30.0x2	X'Y'Z' (4:4:4)	12-bits

Specification	Resolution	Frame rate (per eye)	Color format	Bit depth
SMPTE 2048-1-2011 Am1:2016	4096x2160	48.0x2	X'Y'Z' (4:4:4)	12-bits
SMPTE 2048-1-2011 Am1:2016	4096x2160	50.0x2	X'Y'Z' (4:4:4)	12-bits
SMPTE 2048-1-2011 Am1:2016	4096x2160	60.0x2	X'Y'Z' (4:4:4)	12-bits

HDMI video source connection from an Integrated Media Block (IMB)

The projector can accept digital video data from HDMI sources connected to applicable Integrated Media Block (IMB) devices. The input configurations supported are determined by the IMB device directly.

Contact Christie Technical Support to learn which IMB devices provide HDMI source selection from the projector user interface.

HDMI input selection directly from the IMB may also be possible using the IMB user interface. The input configurations supported are determined by the IMB make and model.

SDI video source connection from an Integrated Media Block (IMB)

The projector can accept digital video data from SDI sources connected to applicable Integrated Media Block (IMB) devices.

The input configurations supported are determined by the IMB device directly. Contact Christie Technical Support to learn which IMB devices provide SDI source selection from the projector user interface.

SDI input selection directly from the IMB may also be possible using the IMB user interface. The input configurations supported are determined by the IMB make and model.

GPIO connector

The Generic Purpose Input Output (GPIO) connector provides a flexible method of interfacing with the projector. 18 GPIO pins are available on the GPIO connector. Two other pins are reserved for ground and power.

The GPIO connector is located on the input panel (*M in the Video Input panel image (on page 32)*).

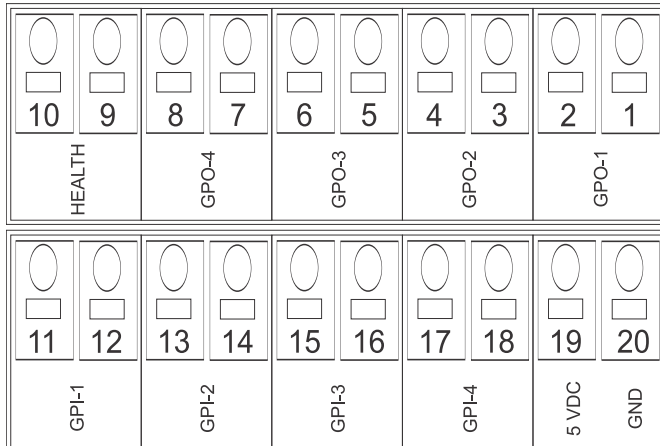

Pin number	Signal name	Direction
Pin 1	GPO1_POS	Out
Pin 2	GPO1_NEG	Out
Pin 3	GPO2_POS	Out
Pin 4	GPO2_NEG	Out
Pin 5	GPO3_POS	Out
Pin 6	GPO3_NEG	Out
Pin 7	GPO4_POS	Out
Pin 8	GPO4_NEG	Out
Pin 9	HEALTH_POS	Out
Pin 10	HEALTH_NEG	Out
Pin 11	GPI1_POS	In
Pin 12	GPI1_NEG	In
Pin 13	GPI2_POS	In
Pin 14	GPI2_NEG	In
Pin 15	GPI3_POS	In
Pin 16	GPI3_NEG	In
Pin 17	GPI4_POS	In
Pin 18	GPI4_NEG	In
Pin 19	+5V	—
Pin 20	GND	—

GPIO inputs

The 5 VDC (pin 19 and pin 20) is intended for use to supply the inputs.

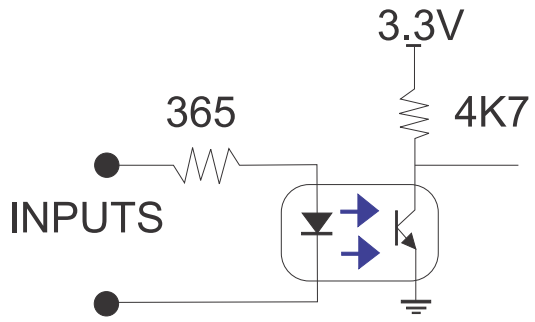

GPIO outputs

Outputs are solid state relays with a 1 A AC/DC rating at up to 48 V.

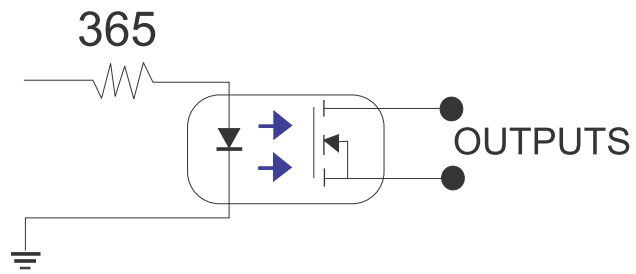

Operation

Learn how to turn on and off the projector. You can operate the projector from the remote UI or from an optional touch panel.

Turning on the projector

Learn how to turn on the projector.

1. Turn on the circuit breaker for the projector.
2. Select and hold **Power**.
3. To ignite the lamp, select and hold the **Light Bulb** icon.

Turning off the projector

Learn how to turn off the projector.

1. Select and hold the **Light Bulb** icon to turn off the lamp.
Perform this step if you want the light source off but to keep the projector powered on. Otherwise, proceed directly to step 2.
2. Select and hold **Power**.
The projector enters a cool-down mode and the fans and electronics stay on for 10 minutes. After this cool-down period, the projector enters Standby mode.

Projector states

Learn what occurs when you select the Power and Lamp icons and the tail light status.

Button pressed	Projector's current state			
—	Enters Standby power mode (Flashing green on the tail light)	Power is on and the lamp is off (Solid green on the tail light)	Power is on and the lamp is on (Solid green on the tail light)	Cool-down mode (Yellow/green flashing on the tail light)
Power On	Powers on to full power (boot delay)	No action	No action	Cancel cool down and goes to full power
Power Off	No action	Powers off immediately	Turns the lamp off immediately; enter cool-down mode	No action

Button pressed		Projector's current state		
Lamp On	Power is on and turns on the lamp (boot delay)	Immediately turns on the lamp	No action	Cancels cool down and immediately turns on the lamp
Lamp Off	No action	No action	Immediately turns off the lamp	No action

Adjusting the image

Learn how to adjust image geometry so it displays correctly.

Maximizing light output

To make sure optimal operation and peak screen brightness, use LampLOC™ to adjust the lamp position when you install a new lamp.

Before running LampLOC™, verify the following:

- The anode yoke is in the correct position for the lamp type.
- The lamp extension nut is installed when using a CDXL-30SD lamp. Remove the nut if not using a CDXL-30SD lamp.
- The lamp is on and the douser is open.

When you complete the LampLOC™ adjustment, the lamp is centered and is the correct distance from the illumination system.

1. In the left navigation menu, select **Lamp Settings > LampLOC**.
2. Select **Auto LampLOC**.

Calibrating the Intelligent Lens System

On CP2420-Xe/CP4420-Xe projectors, the Intelligent Lens System (ILS) is activated by default.

Use the Auto Calibrate feature of the ILS to find and compensate for motor backlash, and to determine the movement range for the currently installed lens.

1. In the left navigation menu, select **Image Settings > ILS File Setup**.
2. From the ILS File list, select an available ILS file.
3. Select **Auto Calibrate**.
4. Select **Continue**.
The system performs the lens calibration.

Aligning the image

Aligning the image ensures when it is reflected from the digital micromirror device (DMD) it is parallel and centered with the lens and screen.

You must complete this procedure before completing a boresight adjustment.

1. Verify the projector is *properly positioned relative to the screen* (on page 20).
2. Display a test pattern to analyze image focus and geometry.
Christie recommends using the Framing test pattern.

3. Perform a preliminary focus and, if available, a zoom adjustment with the primary lens. Focus the center of the image first.
4. Ideally, the image should be centered on the lens and if it is not aligned to the screen in case, start by physically moving the projector; however, if not possible, use the lens shift.
5. With the Framing test pattern on screen, re-check the projector leveling so the top edge of the image is parallel to the top edge of the screen.

Adjusting the offset

Learn how to adjust the offset.

Always adjust offset before boresight.



As boresight is adjusted, the lens offset may require additional minor adjustments.

1. Project an image with the primary lens.
2. Select a framing test pattern and then adjust the horizontal and vertical offset to display a square image on the screen with minimal projector aiming error.

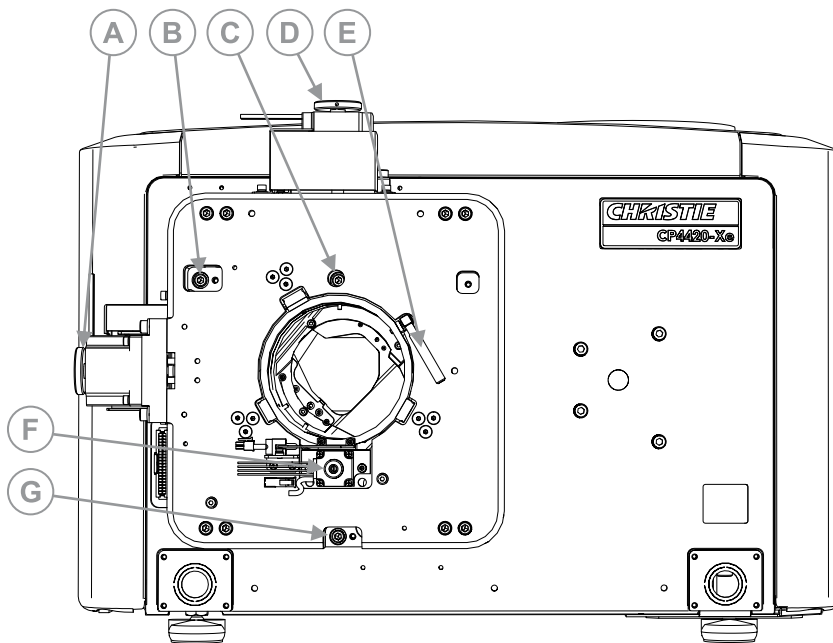

A	Horizontal offset	E	Lens lock
B	Horizontal boresight bolt	F	Focus
C	Anchor bolt	G	Vertical boresight bolt
D	Vertical offset		

For the best optical performance and to minimize keystone error, use offset rather than aiming to center the image in off-axis installations. Avoid extreme tilts or offsets. Corner vignettes on a white test pattern indicate extreme offset that should be corrected by using mechanical alignment.

Adjusting offset by using an ILS

Learn how to adjust the offset by using an Intelligent Lens System™ (ILS).

Always adjust the offset before adjusting boresight.



As boresight is adjusted, the lens offset may require additional minor adjustments.

1. Project an image with the primary lens.
2. Make sure lens calibration is completed before creating the ILS file.
3. Select **Test Patterns** and select a framing test pattern.
4. In the left navigation menu, select **Image Settings > ILS File Setup**.
5. Select the directional arrows in the Offset area.

For best optical performance, make sure to minimize keystone error by using the offset more than aiming to center the image in an off-axis installation. Avoid extreme tilts or offsets. Corner vignettes on a white test pattern indicates extreme offset that should be corrected by using mechanical alignment.

Correcting vignetting

An image that is brighter at the center than it is at the sides needs vignetting correction.

If your image suffers from vignetting, the lens has reached the end of its offset travel range.

If your installation does not allow the image to be centered with the center of the screen, move the entire projector in the direction of lens travel.

Correcting keystone effect

Keystone effect occurs when you project an image onto the screen at an angle. As a result, the image appears distorted and resembles a trapezoid.

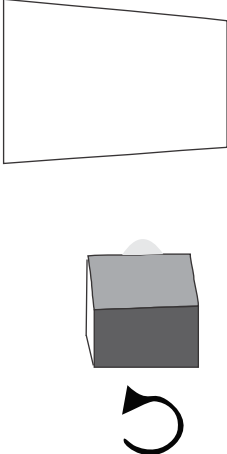
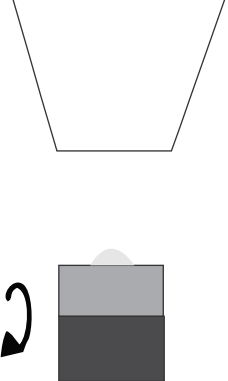

When making the adjustments, set the light source to minimum power.

Horizontal keystone	Vertical keystone
	
<p>Projector skewed horizontally to the screen</p>	<p>Projector tilted vertically to the screen</p>

1. If the image suffers from slight keystone effect, it can be corrected with electronic cropping.
2. If the keystone effect is severe, unevenly adjust the feet to compensate for projector tilt. Christie recommends using the lens offset to align the center of the image to the center of the screen before correcting the keystone effect.
3. If one side of the image is longer than another, adjust the tilt and level of the projector.

Adjusting the left and right boresight

Learn how to adjust the left and right boresight.



Warning! If not avoided, the following could result in death or serious injury.

- This procedure must be performed by Christie qualified technicians.



Caution! If not avoided, the following could result in minor or moderate injury.

- Do not look directly into the lens when the light source is on. The extremely high brightness can cause permanent eye damage.

When performing boresight adjustments, the goal is to balance the tilt of the lens mount to compensate for screen-to-projector tilt but also to precisely maintain the original factory settings of the lens mount axial position.

1. Loosen the lock screws highlighted in the image below.

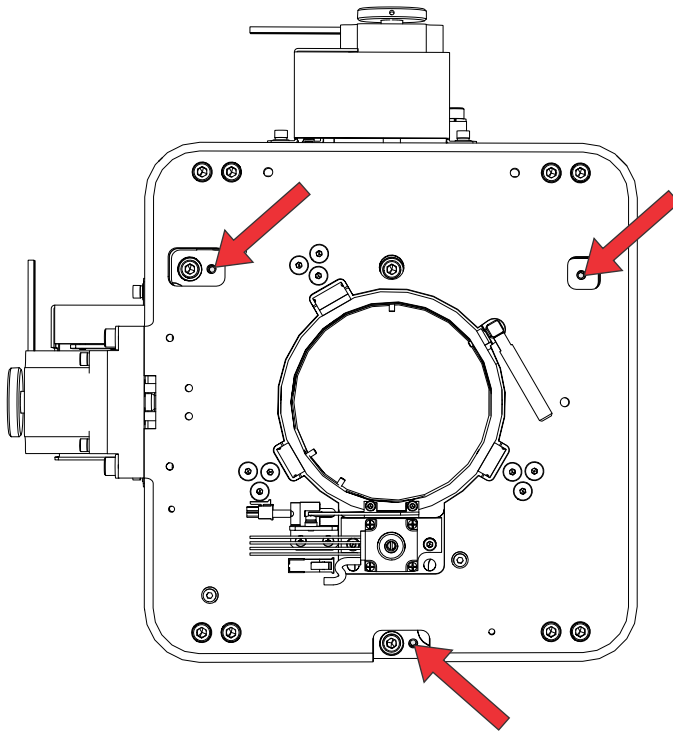

2. Extend the lens focus completely.
3. Adjust the Focus using the focus knob to retract the lens.
 Watch the image at the left edge of the screen until it comes into focus. If the entire screen is in focus, proceed to step 7.

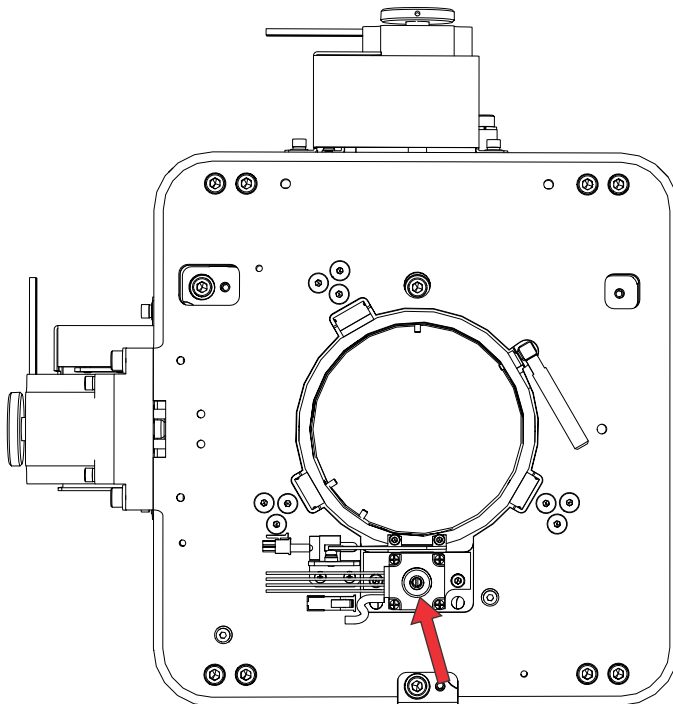

4. Continue retracting the lens.
 - a) If the right edge of the image comes into focus before the lens is completely retracted, adjust the horizontal boresight screw to direct or aim the lens mount towards the left of the screen to balance out the left and right edges.

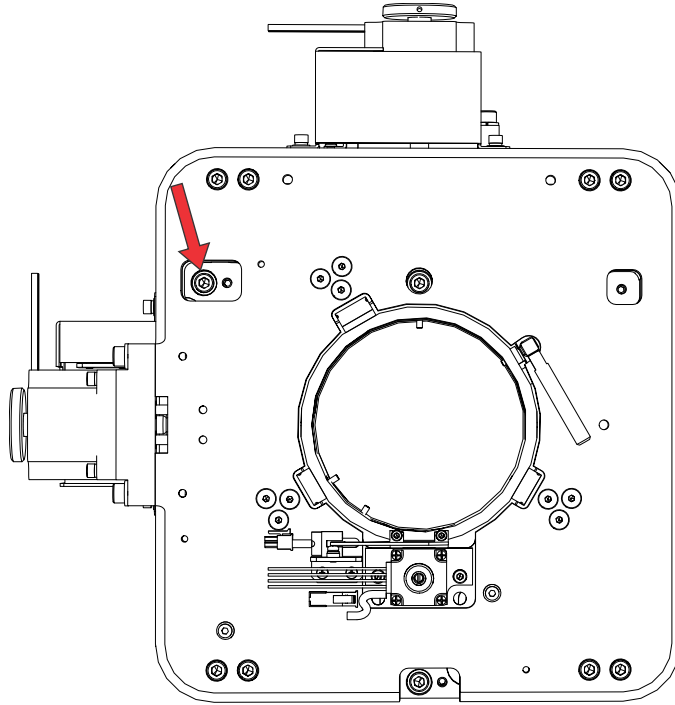

- b) If the left edge of the image is not in focus, adjust the horizontal boresight screw to direct or aim the lens mount toward the right side of the screen.
5. When both sides appear equally blurry, adjust the horizontal or vertical offset to re-center the image.
6. Repeat steps 1 to 5 until both sides of the image are focused.
7. Tighten the horizontal hold screw to maintain the adjustments.
8. Check the boresight again.

Adjusting the top and bottom boresight

Learn how to adjust the top and bottom boresight.



Warning! If not avoided, the following could result in death or serious injury.

- This procedure must be performed by Christie qualified technicians.



Caution! If not avoided, the following could result in minor or moderate injury.

- Do not look directly into the lens when the light source is on. The extremely high brightness can cause permanent eye damage.

1. Focus the image at the top edge of the screen.
2. Loosen the lock screws highlighted in the image below.

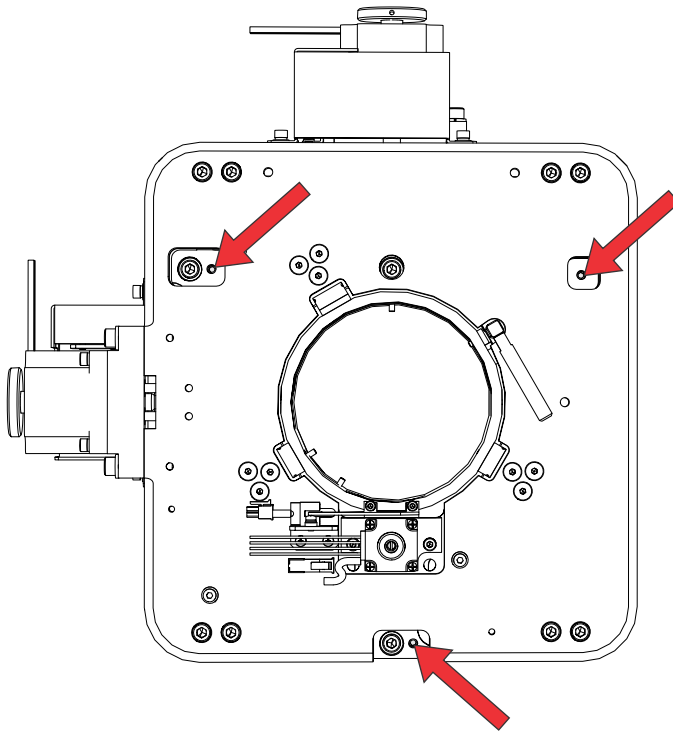

3. Extend the lens focus completely.

4. Adjust the focus knob to retract the lens.

Watch the image at the top edge of the screen until it comes into focus. If the entire screen is in focus, proceed to step 8.

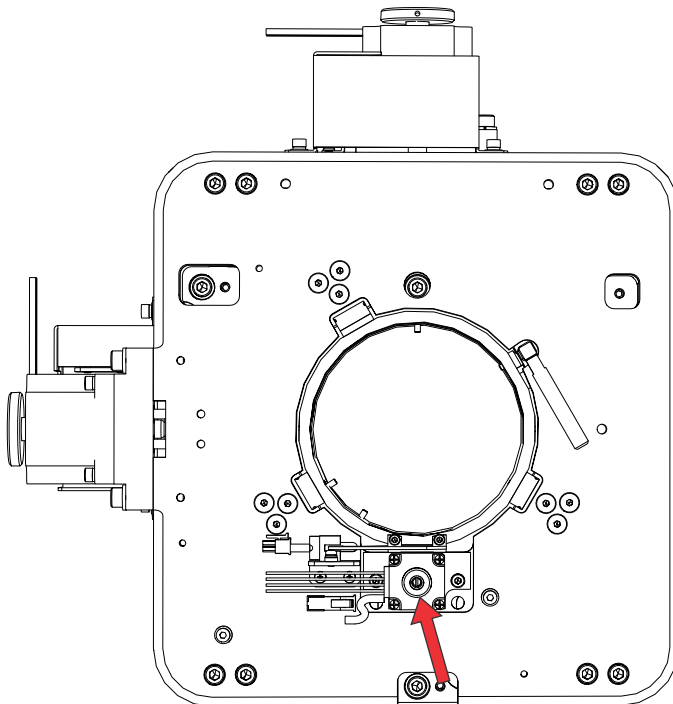

5. Continue retracting the lens.
 - a) If the bottom edge of the image comes into focus before the lens is completely retracted, adjust the vertical boresight screw to direct or aim the lens mount up towards the top of the screen to balance out the top and bottom edges.

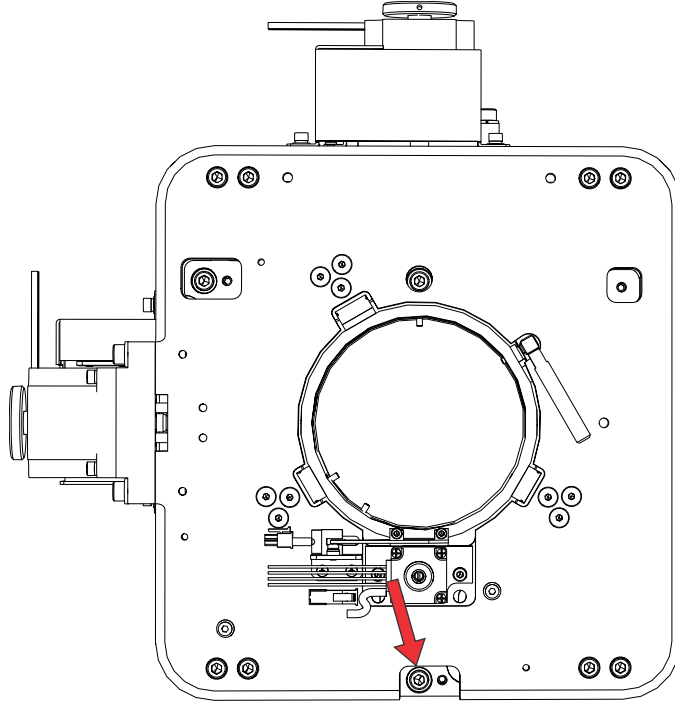

- b) If the top edge of the image is not in focus, adjust the vertical boresight screw to direct or aim the lens mount toward the bottom of the screen.
6. When both sides appear equally blurry, adjust the horizontal and/or vertical offset to re-center the image on the screen.
7. Repeat Steps 2 to 5 until the top and bottom of the screen are both focused.
8. Re-focus the center of the image.
The image should be focused at the center and on all sides.
9. Tighten the vertical hold screw to maintain the adjustments.
10. Check the boresight again.

Electronic Color Correction (ECC)

A lateral convergence error occurs when the red, green, and blue (RGB) primary colors are not converged through projected lenses and is most noticeable at the edges of the screen. To address this, use ECC.

Electronic Color Correction (ECC) is accomplished by aligning a red, green, and blue sprite, which is displayed at the four corners of the displayed image. For electronic convergence all three colors can be adjusted.

Always align the color components of the sprite to the inner most line color (for each axis). When converged, the three colors should overlap to form white lines. Applying the sprite alignment settings to the screen results in the three colors overlapping to form white lines throughout the image.

One or more poorly converged individual colors may appear adjacent to some or all of the lines.

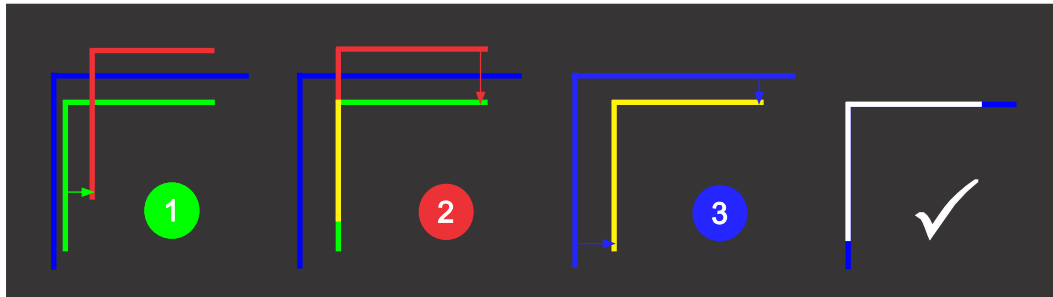

If you wear glasses with corrective lenses when performing this adjustment, make sure you are viewing the test pattern on a straight angle through the optical axis of your glasses and not from a tilted or angled perspective. This avoids a prismatic effect that can appear to shift convergence when viewing at an angle.

Mechanically adjusting digital micromirror device (DMD) convergence for CP2420-Xe

A convergence problem can be identified when one or more projected colors (red, green, and blue) appears misaligned when examined with a convergence test pattern.

Only applies to: CP2420-Xe

The physical layout of the red and green formatter boards dictates the behavior of the twist and vertical adjustments:

- The adjustment of the two is more like a twist with the left-side of the screen as a sliding hinge point to allow vertical travel.
- The vertical adjustment screw and twist adjustment screw interact with each other so if one is turned in the opposite direction of the other, the twist is affected.
- If both screws are turned equal amounts in the same direction, the image moves vertically.

1. Before adjusting digital micromirror device (DMD) convergence, make sure the projector has reached a steady operational state.

If switching from a white or bright test pattern to a dark convergence test pattern or if warming up the projector after a shutdown, allow 15 minutes for stabilization so the optics can reach a steady state.

2. In the right toolbar, select **Test Patterns**. 
3. Select the **RGB-2K-Convergence** test pattern and display it full screen.

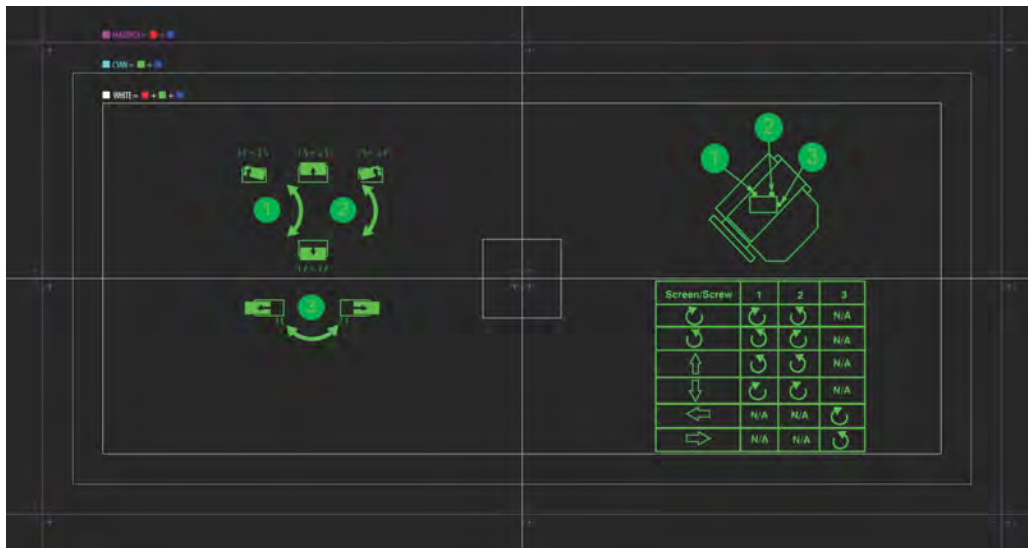

4. Access the screws on the light engine.

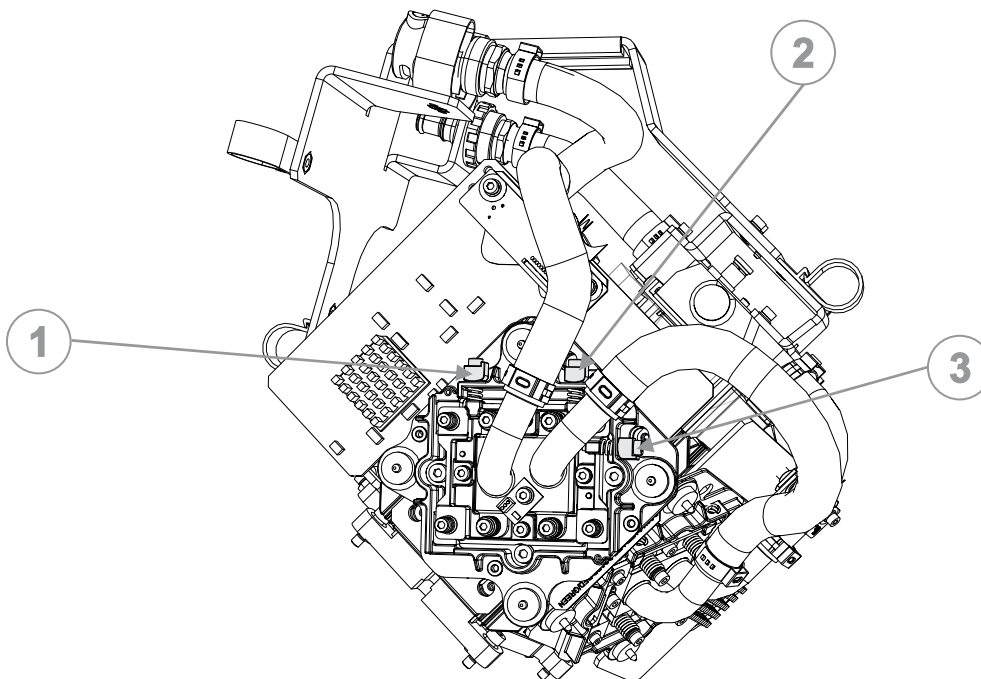

5. Use the Convergence test pattern to assist with adjusting the horizontal and vertical lines.

















6. Locate the shorter blade 2.5 mm driver on adjusting screw #2 (especially on the red) and use the longer blade 2.5 mm driver for screw#1 and horizontal (screw #3).

Do not apply excessive force on the adjustment screws. This can cause the convergence adjustment to become misaligned once you remove the adjustment tool.

7. Locate the twist adjustment screw with the 2.5 mm Allen driver and leave it in place, resting against the lens mount/formatter board.

You do not always have to turn the screws simultaneously; however, adjusting one at a time causes the need for an equal or equal and opposite turn on the other to prevent binding to

achieve the required adjustment. If attempting to adjust the twist and increased resistance is encountered on the twist adjustment screw, do the following:

Screen/screw	1	2	3
			—
			—
			—
			—
	—	—	
	—	—	

8. Insert and remove a second driver to adjust the horizontal/twist adjustment screw or the vertical adjustment screw.

Mechanically adjusting digital micromirror device (DMD) convergence for CP4420-Xe

A convergence problem can be identified when one or more projected colors (red, green, and blue) appears misaligned when examined with a convergence test pattern.

Only applies to: CP4420-Xe

When adjusting the convergence, you are adjusting red and green to blue.

1. Before adjusting digital micromirror device (DMD) convergence, make sure the projector has reached a steady operational state.
If switching from a white or bright test pattern to a dark convergence test pattern or if warming up the projector after a shutdown, allow 15 minutes for stabilization so the optics can reach a steady state.
2. In the right toolbar, select **Test Patterns**. 
3. Select the **RGB-4K-Convergence** test pattern and display it full screen.

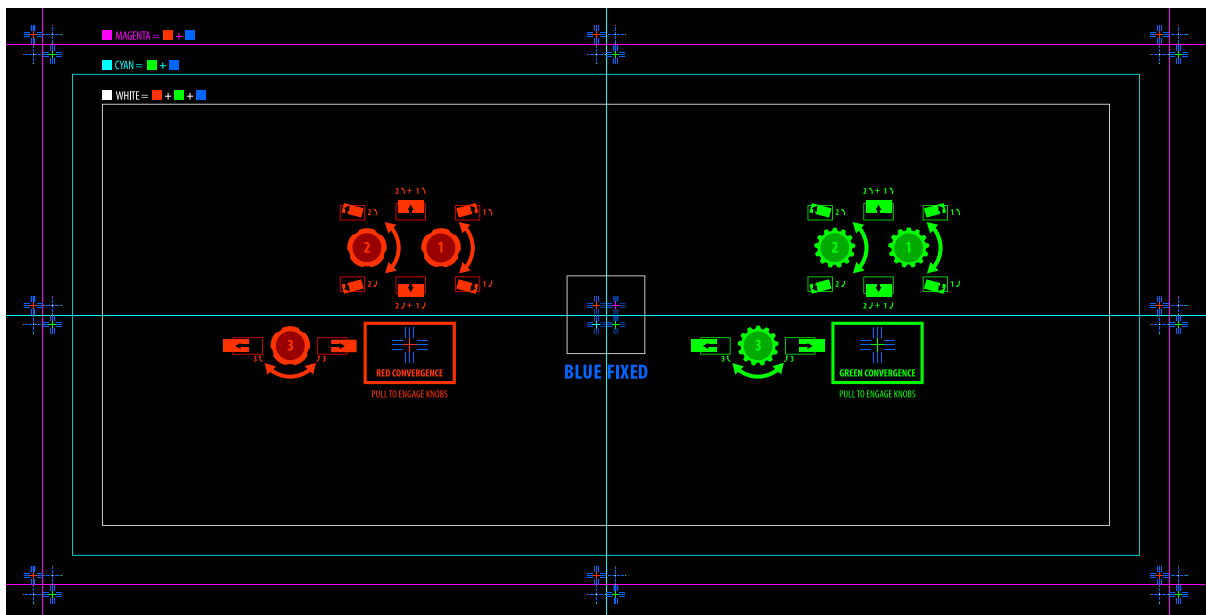

4. Remove the front top cover.
5. To adjust the convergence knobs, use the 3 mm driver included with the projector.
If adjusting by hand without using the tool, pull out the convergence adjustment knobs to engage them.

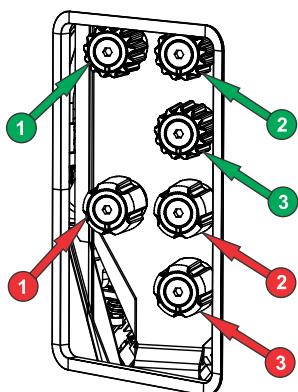

6. Use the Convergence test pattern to assist with adjusting the horizontal and vertical lines.
Horizontal adjustments are controlled by adjusting knob 3.
Vertical convergence and rotation are controlled by adjusting knobs 1 and 2. Christie recommends rotating a single knob a maximum of a quarter rotation before adjusting the second knob a quarter rotation. For example, if using one hand, turn the left knob a quarter rotation and then the right knob a quarter rotation, and so on. Adjusting a single knob for vertical or rotational adjustment to an extreme before adjusting the second knob may result in the convergence mechanism binding.



For the best stability, Christie recommends setting convergence while rotating the knobs in a clockwise direction. This may require first adjusting convergence by turning the knobs counter-clockwise and finalizing the convergence with a clockwise approach. This applies to all knobs.

7. When complete, push in all the convergence adjustment knobs to disengage them.

Electronically adjusting convergence

Use the electronic convergence feature in the menu to adjust convergence. Only perform electronic convergence when satisfied with the position of the image on the screen.

1. In the left navigation menu, select **Image Settings > ILS File Setup**.
2. Use the arrow to select an ILS file to store the ECC settings.
3. On the ILS File Setup page, select **ECC**. 

Each corner of the screen displays three separate sprites, one for each primary color. The user interface displays the Test Pattern controls.

4. Set the Screen Type to **Flat** or **Scope**.

This sets the test pattern and the location of the sprites on the screen. Each sprite appears as the letter L.

5. Set the Sprite Color to **Move** and **Show**.

When first opening the ECC, all Show and all Move colors are selected, so all three sprites are displayed and all three sprites are moved by the directional pad.

6. Select a **Step Size** to control the granularity of the steps from coarse (1/8 pixel per step) to fine (1/64 pixel per step) when using the directional pad.

Sprites can be moved a maximum of 20 pixels.

7. Choose a corner by selecting the circle at a corner of the dashed rectangle.

The selected corner is indicated by a green circle. The X/Y pixel offset (from no correction) displays in red, green, and blue text corresponding to each sprite.

8. Use the directional pad to move the sprites towards the center of the screen.
9. Adjust each sprite so they overlap to create a single white sprite.

In the example below, the red sprite (in image 1 below) was moved down and the blue sprite (in image 1 below) was moved to the right so they overlap to create the single white sprite (image 2 below).

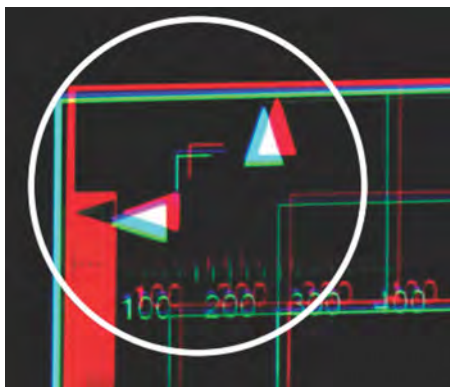

1



2

10. To set the convergence for that corner of the screen, select **Apply**.

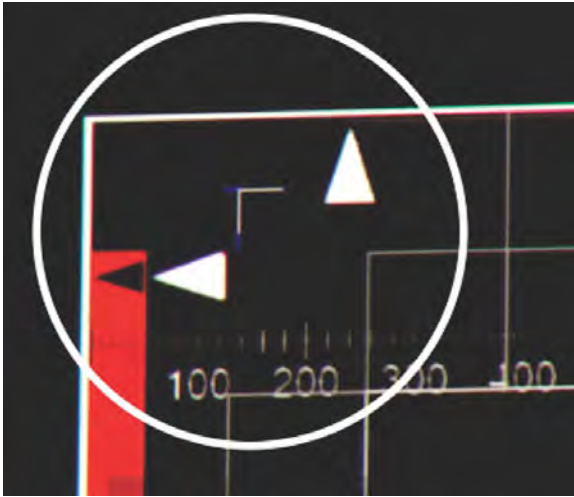

11. Repeat steps 7 to 10 for the remaining corners.
12. If necessary, reset the correction back to zero (no correction) or the previously saved correction by selecting **Reset**.
In the Reset dialog, reset the current corner or all four corners. When the locations and value are set, select **Reset**.
13. To save the current ECC settings, when the convergence is complete, select **Save** beside the ILS file named at the top of the panel.

Adjusting the fold mirror

When properly aligned, the fold mirror directs light from the integrator fully and precisely onto the digital micromirror device (DMD) pixels. If a corner or edge of an image is missing, the fold mirror might be misaligned with the optical system.

After moving or replacing the fold mirror, check for consistent light over-spill around the perimeter of a full white or black field—if the shadows vary or disappear completely along any edge or corner, the fold mirror is cropping light from the DMDs and must be realigned. When corrected, the shadows cast by the integrator edges form an even perimeter around the full active display area without interfering with the image and all of the image is displayed.

1. To raise or lower the image, adjust the screw closest to the right side on the base of the projector.

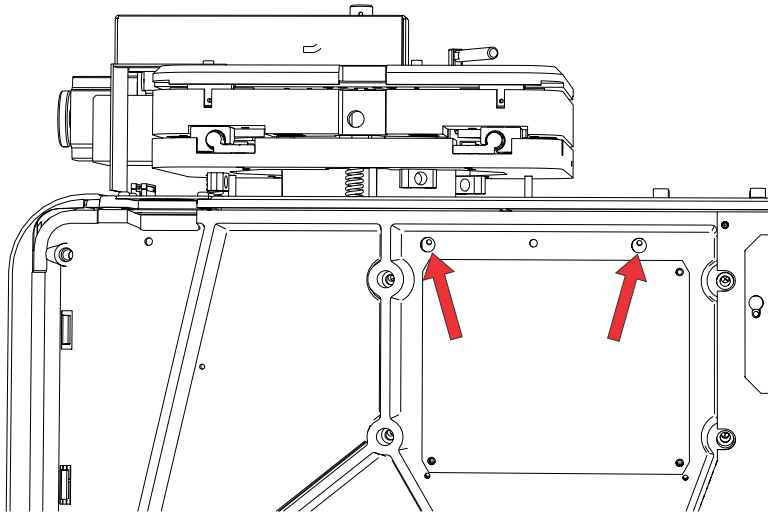

2. To move the image left or right, adjust the screw farthest from the right side.

Aligning the integrator module

The integrator module is located early in the light path, between the UV filter and cold mirror.

The main component of the integrator module, the internal solid silica pipe, efficiently converts the initial round light beam supplied from the lamp into a uniform rectangle that passes through the remainder of the optical system and eventually illuminates the three DMDs at the opposite end of the light path. Therefore, when the integrator module is moved or replaced, its end-to-end position and its rotation must be correct for proper focus and full illumination of the three DMDs.



Caution! If not avoided, the following could result in minor or moderate injury.

- UV EXPOSURE! Protective UV safety glasses with side shields and protective safety clothing approved by Christie must be worn when performing optical adjustments or servicing the product.

1. Display a full white field.
2. Loosen the integrator assembly so it can be manually moved.
3. Adjust the focus.

Corners should be equal in focus, although they may appear slightly blurry. As necessary, move the integrator forward or backward along its axis for an equal level of focus in all corners. For best results, double-check the perimeter shadows with a full black field.

4. Center the white field.

Confirm all shadowy edges cast by the integrator are projected off the screen, with the white field fully visible and centered between shadows. If necessary, use the fold mirror adjustment screws to precisely direct the white field between all edge shadows. Centering signifies the rectangle of light passed from the integrator completely illuminates the DMDs.

Calibrating the color

Use Measured Color Gamut Data (MCGD) files to correct on-screen colors.

1. Using a colorimeter, measure the colors displayed on the screen from the center of the audience viewing location to determine the Measured Color Gamut Data (MCGD) value.
2. In the left navigation menu, select **Color Settings > MCGD File Setup** and enter the color values in the x and y fields for the different colors.
3. Select **Save**.
4. Update the relevant channel settings to use the MCGD file created.
5. Select the TCGD file suitable for the content played while the channel is active.

Regulatory

This product conforms to the latest regulations and standards related to product safety, environmental, and electromagnetic compatibility (EMC) requirements.

Safety

- CAN/CSA C22.2 No. 60950-1
- EN 60950-1
- IEC 60950-1 IEC/EN 60950-1 – Information Technology Equipment – Safety – Part 1: General Requirements
- IEC 60950-1 – Information Technology Equipment – Safety – Part 1: General Requirements
- IEC 62368-1: 2014 – Audio/video, information and communication technology equipment - Part 1: Safety requirements
- EN 62368-1:2014 + A11:2017 – Audio/video, information and communication technology equipment - Part 1: Safety requirements
- UL 62368-1: 2014 – Audio/video, information and communication technology equipment - Part 1: Safety requirements
- CAN/CSA-C22.2 No. 62368-1: 2014 – Audio/video, information and communication technology equipment - Part 1: Safety requirements
- IEC/EN 62471-5 – Photobiological Safety of Lamps and Lamp Systems – Part 5: Image projectors

Electro-magnetic compatibility

Emissions

- CAN ICES-003 (A)/NMB-003 (A) – Information Technology Equipment (Including Digital Apparatus) – Limits and Methods of Measurement
- CISPR 22/EN 55022, Class A
- FCC CFR47, Part 15, Subpart B, Class A – Unintentional Radiators

Immunity

- CISPR 24/EN55024 EMC Requirements – Information Technology Equipment

Environmental

- China Ministry of Information Industry (along with 7 other Government Agencies) Order No.32 (01/2016) on the control of pollution caused by electronic information products, hazardous substances concentration limits (GB/T 26572 - 2011), and the applicable product marking requirement (SJ/T 11364 - 2014).
- EU Directive (2011/65/EU) on the restriction of the uses of certain hazardous substances (RoHS) in electrical and electronic equipment and the applicable official amendment(s).
- EU Directive (2012/19/EU) on waste and electrical and electronic equipment (WEEE) and the applicable official amendment(s).
- Regulation (EC) No. 1907/2006 on the registration, evaluation, authorization and restriction of chemicals (REACH) and the applicable official amendment(s).

