

Preparing Christie Eclipse for initial use

The reservoir plug is used during transit to prevent coolant leaks. It must be removed during the installation of the projector.

Affected products

The following products are affected:

- Christie Eclipse

Removing the reservoir plug

Prior to using the projector, remove the plug from the reservoir assembly.

1. To access the 2K liquid cooling pump, remove the rear lower cover:
 - a) Remove the three screws along the top of the rear lower cover.

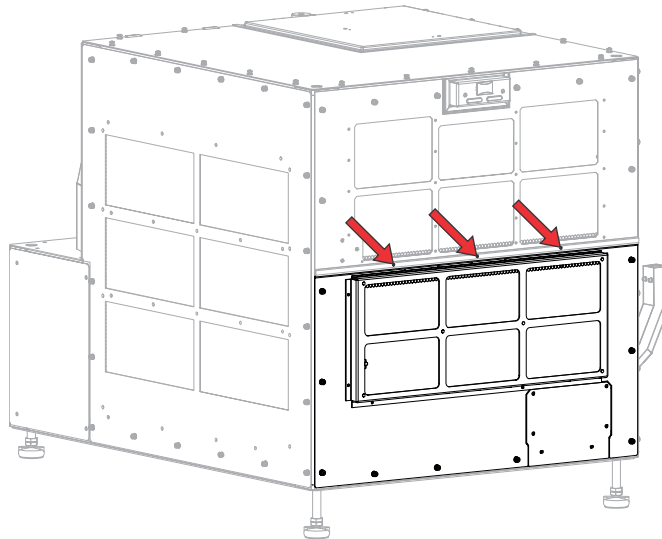

- b) Loosen the nine screws and remove the rear lower cover.

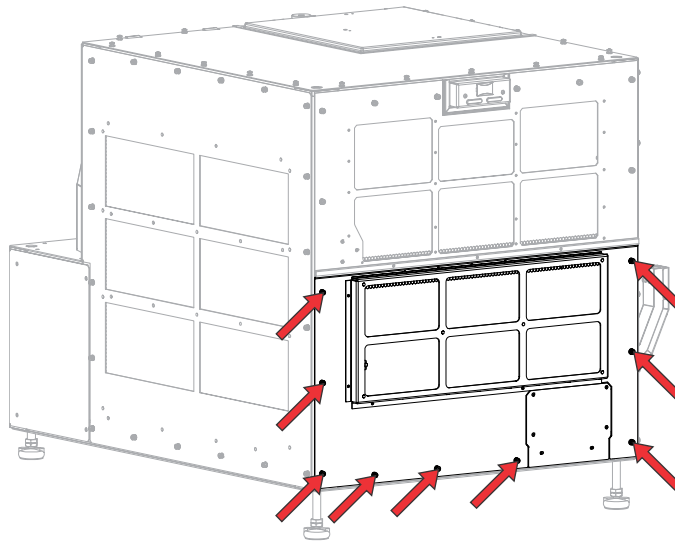

2. Locate the 2K liquid cooling pump.

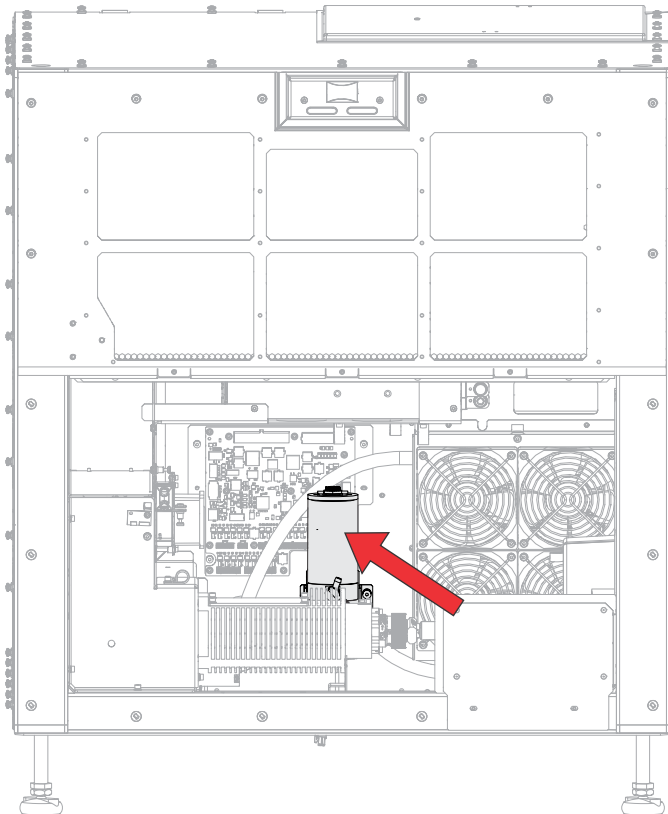

3. Leaving the 2K liquid cooling pump in the projector, remove the plug from the reservoir's cap.

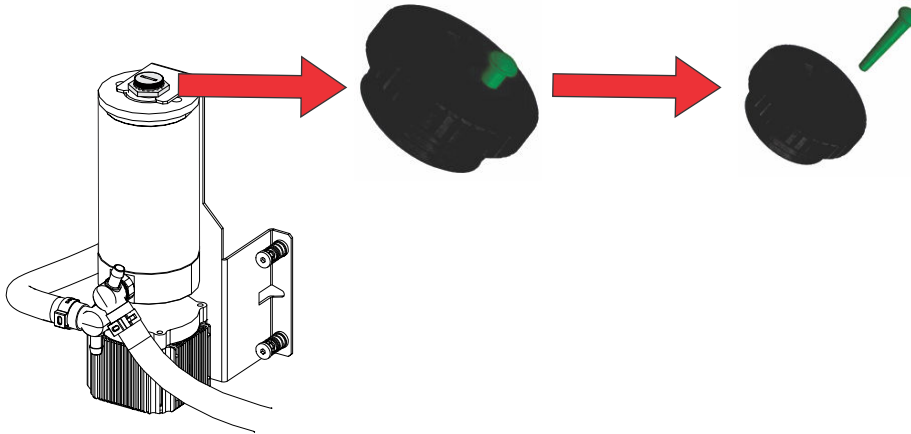

4. Tape the plug to the top of the cap so it is available for reinsertion if the projector is to be transported in the future.
Alternatively, order a new plug in the Reservoir Cap service kit (P/N: 003-200638-XX).
5. Replace the rear lower cover.

Technical support

Technical support for Christie Enterprise products is available at:

- North and South America: +1-800-221-8025 or Support.Americas@christiedigital.com
- Europe, Middle East, and Africa: +44 (0) 1189 778111 or Support.EMEA@christiedigital.com
- Asia Pacific (support.apac@christiedigital.com):
 - Australia: +61 (0)7 3624 4888 or tech-Australia@christiedigital.com
 - China: +86 10 6561 0240 or tech-supportChina@christiedigital.com
 - India: +91 (80) 6708 9999 or tech-India@christiedigital.com
 - Japan: 81-3-3599-7481
 - Singapore: +65 6877-8737 or tech-Singapore@christiedigital.com
 - South Korea: +82 2 702 1601 or tech-Korea@christiedigital.com
- Christie Professional Services: +1-800-550-3061 or NOC@christiedigital.com