

Motor kit installation instructions

This instruction sheet provides information on how to replace the Fixed Motor (P/N 003-002552-XX) and Zoom Motor kits (P/N 003-002553-XX) onto a projection lens.

Affected products

The following products are affected.

- | | | | |
|--------------|-------------------|--------------------|--------------------|
| • CP2000-M | • HD14K-M | • Mirage HD10K-M | • Roadster S+10K-M |
| • DS+6K-M | • Matrix HD350 | • Mirage HD14K-M | • Roadster WU12K-M |
| • DS+10K-M | • Matrix HD200 | • Mirage WU7K-M | • Roadster WU14K-M |
| • DS+14K-M | • Matrix S+200 | • Mirage WU12K-M | • WU7K-M |
| • DVL1400-DL | • Matrix S+350 | • Mirage WU14K-M | • WX7K-M |
| • DLV1920-DL | • Mirage DS+10K-M | • Roadster DS+14K | • WU14K-M |
| • HD6K-M | • Mirage DS+14K-M | • Roadster HD10K-M | • WX10K-M |
| • HD10K-M | • Mirage HD6K-M | • Roadster HD14K-M | • WU12K-M |

Required components and tools

The following components and tools are required for the motorized projection lens replacement.

- Motor Fixed kit (P/N 003-002552-XX)
- Motor Zoom kit (P/N 003-002553-XX)
- 2.5 mm hex key

Replacing the motorized projection lens



Caution! If not avoided, the following could result in minor or moderate injury.

- Do not operate the product without a lens installed.
1. Turn off the projector and disconnect it from AC power.
 2. Turn off the light source and cool the projector for at least 15 minutes.
 3. Make sure the protective lens cap is in place before removing the lens.
 4. Position the lens on a flat/stable surface.

- Turn the two screws securing the cover 1/4 of a turn (one screw shown as A in the image below).



- Slide off the cover (B in the image in step 6).
- Remove the two screws from each motor.

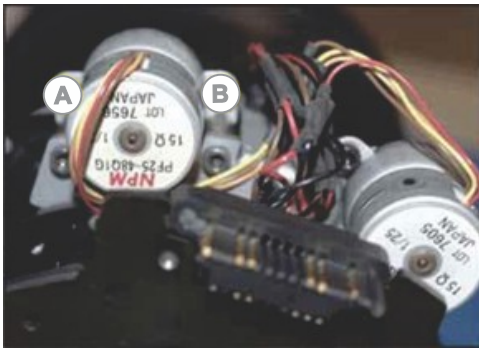

- Remove the two screws (A in the image below) securing the motor harness to the lens.



- Identify the lens type being used and pin the jumper wires into the connector according to the below chart.

Pin connection chart:

Signal	Wire	1.5-2.0SX+ ILS/ 1.4-1.8 HD	2.0-2.8SX+ ILS/ 1.8-2.6 HD	2.8-4.5SX+ ILS/ 2.6-4.1 HD	4.5-7.5SX+ ILS/ 4.1-6.9 HD	7.5-11.2SX+ ILS/ 6.9-10.4 HD	1.25-1.6SX+ ILS/ 1.16-1.49 HD	1.2SX+ ILS/ 1.1 HD	0.73SX+ ILS/ 0.67 HD	All DLP lenses
Zoom_Step_A1	Pin-1									
Zoom_Step_A2	Pin-2									
Zoom_Step_B1	Pin-3									
Zoom_Step_B2	Pin-4									
GND	Pin-5									
LensID_0	Pin-6	←		←	←	←		←		←
Focus_Step_A1	Pin-7									
Focus_Step_A2	Pin-8									
Focus_Step_B1	Pin-9									
Focus_Step_B2	Pin-10									
Zoom-SW-Gnd	Pin-11									
Zoom-SW-Vcc	Pin-12									
Zoom-SW-Out	Pin-13									
GND	Pin-14	←	←		←	←		←	←	←
LensID_1	Pin-15	←	←		←	←		←	←	←
GND	Pin-16						←	←	←	←
LensID_2	Pin-17				←	←	←	←	←	←
Focus-SW-Gnd	Pin-18									
Focus-SW-Vcc	Pin-19									
Focus-SW-Out	Pin-20									

Connector for pinning jumper wires:

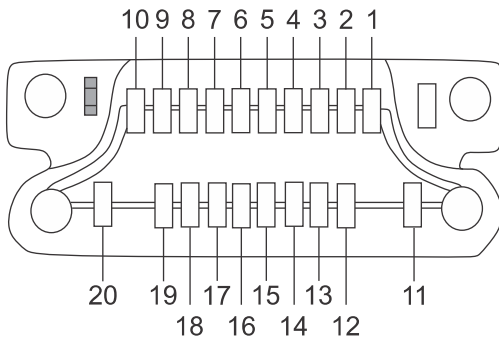

Supported lenses and part numbers:

Lens	Part number
1.5-2.0SX+ ILS/1.4-1.8 HD	118-100112-XX
2.0-2.8SX+ ILS/1.8-2.6 HD	118-100113-XX
2.8-4.5SX+ ILS/2.6-4.1 HD	118-100114-XX
4.5-7.5SX+ ILS/4.1-6.9 HD	118-100115-XX
7.5-11.2SX+ ILS/6.9-10.4 HD	118-100116-XX
1.25-1.6SX+ ILS /1.16-1.49 HD	118-100111-XX
1.2SX+ ILS/1.1 HD	118-100117-XX
0.73SX+ ILS/0.67 HD	118-100110-XX
1.39-1.9 .98" DLP zoom	108-327103-XX
1.2-1.75 .98" DLP zoom	108-350109-XX
2.4-3.9 .98" DLP zoom	108-322108-XX
1.05:1 .98" DLP zoom	108-319104-XX
1.9-3.0 .98" DLP zoom	108-328104-XX
1.75-2.4 .98" DLP zoom	108-321107-XX
1.5-2.2 .98" DLP zoom	108-329105-XX

Lens	Part number
3.9-6.5 .98" DLP zoom	108-323109-XX
1.3-1.75 .98" DLP zoom	108-320106-XX

10. When installing the new motors, apply loctite to the motor and the motor harness screws. Make sure the screws remain centered in the mounting holes when tightening to prevent the motor gears from binding. Failure to do so could result in the motors skipping.

Technical support

Technical support for Christie Enterprise products is available at:

- North and South America: +1-800-221-8025 or *Support.Americas@christiedigital.com*
- Europe, Middle East, and Africa: +44 (0) 1189 778111 or *Support.EMEA@christiedigital.com*
- Asia Pacific (*support.apac@christiedigital.com*):
 - Australia: +61 (0)7 3624 4888 or *tech-Australia@christiedigital.com*
 - China: +86 10 6561 0240 or *tech-supportChina@christiedigital.com*
 - India: +91 (80) 6708 9999 or *tech-India@christiedigital.com*
 - Japan: 81-3-3599-7481
 - Singapore: +65 6877-8737 or *tech-Singapore@christiedigital.com*
 - South Korea: +82 2 702 1601 or *tech-Korea@christiedigital.com*
- Christie Professional Services: +1-800-550-3061 or *NOC@christiedigital.com*