

D4K35



Setup Guide

020-100855-02

D4K35

Setup Guide

020-100855-02

NOTICES

COPYRIGHT AND TRADEMARKS

Copyright ©2014 Christie Digital Systems USA Inc. All rights reserved.

All brand names and product names are trademarks, registered trademarks or trade names of their respective holders.

GENERAL

Every effort has been made to ensure accuracy, however in some cases changes in the products or availability could occur which may not be reflected in this document. Christie reserves the right to make changes to specifications at any time without notice. Performance specifications are typical, but may vary depending on conditions beyond Christie's control such as maintenance of the product in proper working conditions. Performance specifications are based on information available at the time of printing. Christie makes no warranty of any kind with regard to this material, including, but not limited to, implied warranties of fitness for a particular purpose. Christie will not be liable for errors contained herein or for incidental or consequential damages in connection with the performance or use of this material. Canadian manufacturing facility is ISO 9001 and 14001 certified.

WARRANTY

Products are warranted under Christie's standard limited warranty, the complete details of which are available by contacting your Christie dealer or Christie. In addition to the other limitations that may be specified in Christie's standard limited warranty and, to the extent relevant or applicable to your product, the warranty does not cover:

- a. Problems or damage occurring during shipment, in either direction.
- b. Projector lamps (See Christie's separate lamp program policy).
- c. Problems or damage caused by use of a projector lamp beyond the recommended lamp life, or use of a lamp other than a Christie lamp supplied by Christie or an authorized distributor of Christie lamps.
- d. Problems or damage caused by combination of a product with non-Christie equipment, such as distribution systems, cameras, DVD players, etc., or use of a product with any non-Christie interface device.
- e. Problems or damage caused by the use of any lamp, replacement part or component purchased or obtained from an unauthorized distributor of Christie lamps, replacement parts or components including, without limitation, any distributor offering Christie lamps, replacement parts or components through the internet (confirmation of authorized distributors may be obtained from Christie).
- f. Problems or damage caused by misuse, improper power source, accident, fire, flood, lightning, earthquake or other natural disaster.
- g. Problems or damage caused by improper installation/alignment, or by equipment modification, if by other than Christie service personnel or a Christie authorized repair service provider.
- h. Problems or damage caused by use of a product on a motion platform or other movable device where such product has not been designed, modified or approved by Christie for such use.
- i. Problems or damage caused by use of a projector in the presence of an oil-based fog machine or laser-based lighting that is unrelated to the projector.
- j. For LCD projectors, the warranty period specified in the warranty applies only where the LCD projector is in "normal use" which means the LCD projector is not used more than 8 hours a day, 5 days a week.
- k. Except where the product is designed for outdoor use, problems or damage caused by use of the product outdoors unless such product is protected from precipitation or other adverse weather or environmental conditions and the ambient temperature is within the recommended ambient temperature set forth in the specifications for such product.
- l. Image retention on LCD flat panels.
- m. Defects caused by normal wear and tear or otherwise due to normal aging of a product.

The warranty does not apply to any product where the serial number has been removed or obliterated. The warranty also does not apply to any product sold by a reseller to an end user outside of the country where the reseller is located unless (i) Christie has an office in the country where the end user is located or (ii) the required international warranty fee has been paid.

The warranty does not obligate Christie to provide any on site warranty service at the product site location.

PREVENTATIVE MAINTENANCE

Preventative maintenance is an important part of the continued and proper operation of your product. Please see the Maintenance section for specific maintenance items as they relate to your product. Failure to perform maintenance as required, and in accordance with the maintenance schedule specified by Christie, will void the warranty.

REGULATORY

The product has been tested and found to comply with the limits for a Class A digital device, pursuant to Part 15 of the FCC Rules. These limits are designed to provide reasonable protection against harmful interference when the product is operated in a commercial environment. The product generates, uses, and can radiate radio frequency energy and, if not installed and used in accordance with the instruction manual, may cause harmful interference to radio communications. Operation of the product in a residential area is likely to cause harmful interference in which case the user will be required to correct the interference at the user's own expense.

CAN ICES-3 (A) / NMB-3 (A)

(A)

, 가

Environmental

The product is designed and manufactured with high-quality materials and components that can be recycled and reused. This symbol  means that electrical and electronic equipment, at their end-of-life, should be disposed of separately from regular waste. Please dispose of the product appropriately and according to local regulations. In the European Union, there are separate collection systems for used electrical and electronic products. Please help us to conserve the environment we live in!

1: Introduction

1.1 Labels and Markings 1-1

1.2 AC / Power Precautions..... 1-2

 Power Cords and Attachments 1-2

1.3 Lamp Precautions 1-2

1.4 Contacting Your Dealer 1-3

2: Installation and Setup

2.1 Site Requirements..... 2-1

2.2 Tools Required for Installation..... 2-1

2.3 Projector Components 2-2

 Air Filter Cover and Air Filter 2-2

 Manual Douser Override 2-2

 Exhaust Duct and Vane Switch 2-2

 Adjustable Feet 2-2

 Lamp Door and Lamps 2-2

 LED Status Indicators 2-3

 Motorized Auxiliary Lens Mount (MALM) 2-3

 Projection Lens 2-3

 RS-422 Connector 2-3

 Security Locks 2-3

 Shroud 2-3

 Input Panel 2-3

 Touch Panel Controller (TPC) 2-4

 Lamp Power Supply (LPS) 2-4

2.4 General Installation Safety and Warning Guidelines 2-5

2.5 Position the Projector and lamp Power Supply 2-5

2.6 Secure the Projector..... 2-8

2.7 Adjust Tilt and Level the Projector 2-8

2.8 Install the Touch Panel Controller (TPC)..... 2-9

2.9 Connect External Exhaust Ducting..... 2-10

 2.9.1 Determine the Projector Exhaust CFM Value 2-10

2.10 Remove the Shroud..... 2-11

2.11 Install the Primary Lens..... 2-11

2.12 Install the Optional Anamorphic Lens..... 2-15

2.13 Install the Optional Wide Converter Lens 2-15

2.14 Install The Lamp..... 2-15

2.15 Connect Lamp Power Supply (LPS) 2-16

2.16 Connect the Projector to an Optional Uninterrupted Power Supply 2-20

2.17 Connect Sources and Turn the Projector On 2-20

3: Connect Devices to the Projector

3.1 Connect a Computer or Server 3-3

3.2 Connect Devices to the SCCI Port 3-4

3.3 Connect Devices to the GPIO Port..... 3-5

3.4 Connect Devices to the 3D Connector3-7

4: Adjust the Image

4.1 Maximize Light Output4-1
 4.2 Calibrate Screen Brightness (fL)4-1
 4.3 Basic Image Alignment4-1
 4.4 Adjust Offset.....4-2
 4.5 Adjust Offset with an ILS4-2
 4.6 Adjust Left and Right Boresight.....4-2
 4.7 Adjust Top and Bottom Boresight4-4
 4.8 Adjust Top and Bottom Boresight with an ILS4-5
 4.9 Adjust DMD Convergence4-5
 4.10 Fold Mirror Adjustment.....4-6
 4.11 Calibrate the System4-6
 4.12 Color Calibration4-6
 4.13 Electronic Screen Masking4-7

5: Projector Operation

5.1 Turn the Projector On5-1
 5.2 Turn the Projector Off.....5-1
 5.3 Using the Touch Panel Controller (TPC)5-1

6: Maintenance

6.1 Ventilation6-1
 6.2 Filling the Coolant Reservoir.....6-1
 6.3 Inspect the Lamp.....6-2
 6.4 Inspect and Clean Optics6-2
 6.4.1 Clean the Lens.....6-2
 Remove Fingerprints, Smudges, or Oil6-2
 6.4.2 Cleaning the Lamp Reflector6-3
 Remove Dust6-3
 Remove Fingerprints, Smudges, or Oil6-3
 6.5 Inspect and Clean the Lamp Blower.....6-3
 6.6 Clean the Igniter.....6-3
 6.7 Inspect and Clean the Airflow Interlocks6-3
 6.8 Inspect the Laminar Airflow Device (LAD).....6-4
 6.9 Replace the Lamp6-4
 6-4
 6.10 Rotating the Lamp6-7
 6.11 Replace the Light Engine Air Filter.....6-7
 6.12 Replace the Liquid Cooling Air Filter6-8
 6.13 Replace the Lens6-8

7: Troubleshooting

7.1 Projector Does Not Power ON.....7-1

7.2 Lamp Does Not Ignite 7-1

7.3 Lamp Suddenly Turns OFF 7-2

7.4 Flicker, Shadows Or Dimness 7-2

7.5 LampLOC™ Not Working 7-2

7.6 LiteLOC™ Not Working..... 7-2

7.7 Touch Panel Controller (TPC)..... 7-3

7.8 Trouble Establishing Communication with Projector 7-3

7.9 Blank Screen, No Display of Image 7-3

7.10 Inaccurate Display Colors 7-3

7.11 Display is Not Rectangular..... 7-3

7.12 Display is Noisy..... 7-3

7.13 Display has Suddenly Frozen 7-4

7.14 Data is Cropped from Edges..... 7-4

7.15 The Projector is ON, but There is No Image..... 7-4

7.16 The Display is Jittery or Unstable 7-4

7.17 Portions of the Display are Cut OFF or Warped to the Opposite Edge..... 7-4

7.18 The Display is Faint..... 7-4

 7.18.1 Display Appears Compressed (Vertically Stretched) 7-5

7.19 Inconsistent Picture Quality..... 7-5

1 Introduction

This manual is intended for professionally trained operators of Christie high-brightness projection systems. These operators are qualified to replace the lamp and air filter, but should not attempt to install or service the projector.

Only accredited Christie technicians who are knowledgeable about the hazards associated with high-voltage, ultraviolet exposure, and the high temperatures generated by the projector lamp are authorized to assemble, install, and service the projector.

1.1 Labels and Markings

These warning labels can appear on the projector:

⚠ DANGER Indicates a hazardous situation which that result in death or serious injury.

⚠ WARNING Indicates a hazardous situation which, if not avoided, could result in death or serious injury.

⚠ CAUTION Indicates a hazardous situation that could result in minor or moderate injury.

NOTICE! *Addresses practices not related to personal injury.*

⚠ WARNING Never look directly into the projector lens or at the lamp. The extremely high brightness can cause permanent eye damage. For protection from ultraviolet radiation, keep all projector housings intact during operation. Protective safety gear and safety goggles are recommended when servicing.

⚠ WARNING FIRE HAZARD! Keep hands, clothes, and all combustible material away from the concentrated light beam of the lamp.

⚠ CAUTION Position all cables where they cannot contact hot surfaces or be pulled or tripped over.

⚠ CAUTION 1) The American Conference of Governmental Industrial Hygienists (ACGIH) recommends occupational UV exposure for an 8-hour day to be less than 0.1 microwatts per square centimeters of effective UV radiation. An evaluation of your workplace is advised to assure employees are not exposed to cumulative radiation levels exceeding the government guidelines for your area. 2) Be aware that some medications are known to increase sensitivity to UV radiation.



This projector must be operated in an environment that meets the operating range specification.

1.2 AC / Power Precautions

To correctly install this projector, a certified electrician must install a permanent a single-phase connection from the projector to the AC supply. Operate the projector at the recommended voltage.

⚠ WARNING

Disconnect projector from AC before opening any enclosure.

⚠ CAUTION

- 1) **DO NOT** allow anything to rest on the power cord. Locate the projector where the cord cannot be abused by persons walking on it or objects rolling over it. Never operate the projector if the power cable appears damaged in any way.
- 2) **DO NOT** overload power outlets and extension cords as this can result in fire or shock hazards.
- 3) Note that only qualified service technicians are permitted to open any enclosure on the product and only if the AC has been fully disconnected from the product.

Power Cords and Attachments

⚠ WARNING 1) Verify that you are using a line cord, socket and power plug that meets the appropriate local rating standards. 2) Use only an AC power cord recommended by Christie. Do not attempt operation if the AC supply and cord are not within the specified voltage and power range.

Use only the attachments and/or accessories recommended by Christie. Use of others may result in the risk of fire, shock or personal injury.

1.3 Lamp Precautions

Lamps used in the projector are under high pressure and you must handle them with caution. Lamps can explode and cause serious personal injury if they are dropped or mishandled.

⚠ DANGER EXPLOSION HAZARD! Wear authorized protective safety gear whenever the lamp door is open!

Recommended protective clothing includes, but may not be limited to a polycarbonate face shield, protective gloves, and a quilted ballistic nylon jacket or a welder's jacket. This equipment is included in included in the Christie Protective Clothing Safety Kit #598900-095.

NOTE: Christie's protective clothing recommendations are subject to change. Any local or federal specifications take precedence over Christie recommendations.

⚠ DANGER Lamp may explode causing bodily harm or death. 1) Always wear protective clothing whenever lamp door is open or while handling lamp. 2) Verify those within the vicinity of the projector are also suited with protective clothing. 3) Never attempt to access the lamp while the lamp is on. Wait at least 10 minutes after the lamp turns OFF before powering down, disconnecting from AC and opening the lamp door.

The arc lamp operates at a high pressure that increases with temperature. Failure to allow the lamp to sufficiently cool prior to handling increases the potential for an explosion causing personal injury or property damage.

1.4 Contacting Your Dealer

If you encounter a problem with your Christie projector, contact your dealer. To assist with the servicing of your projector, enter the information in the tables and keep this information with your records.

Table 1.1 Purchase Record

Dealer:
Dealer or Christie Sales/Service Contact Phone Number:
Projector Serial Number*:
Purchase Date:
Installation Date:

** The serial number can be found on the license label located on the front panel.*

Table 1.2 Ethernet Settings

Default Gateway	
Projector IP Address	
Subnet Mask	

2 Installation and Setup

This section explains how to install, connect, and optimize the projector display.

2.1 Site Requirements

To safely install and operate the D4K35 projector, the installation location must meet these minimum requirements:

- **Physical Operating Environment**

- Maximum Ambient Temperature (operating) 35°C
- Minimum Ambient Temperature (operating) 10°C

- **External Exhaust Ducting**

- The installation site must provide a minimum of 450 CFM (ft³/min) external exhaust airflow to ensure adequate cooling of the Xenon arc lamp at less than or equal to 25°C ambient and less than 3,000 feet elevation. Above 25°C or 3,000 feet, 600 CFM is required. For detailed instructions for measuring CFM, see [Section 2.9 Connect External Exhaust Ducting](#).

- **Power Connection**

- A 30-32A double pole, UL listed wall circuit breaker is required. It must be part of the building installation and easily accessible.
- Single-phase 30A connection of AC supply to the terminal block.
- Protection from overcurrents, short circuits, and earth faults must be part of the building installation. The disconnect device (double pole switch or circuit breaker with minimum 3mm contact gap) must be readily accessible within the projection room.

NOTE: *The requirements listed above are applicable for permanently wired installation or power cord connection.*

2.2 Tools Required for Installation

You need these tools to install the D4K35 projector:

- 12" screwdrivers: Phillips #2 (magnetic) and flat
- 19mm and 7/8" wrenches
- Assorted Allen keys (metric)
- Heat extractor
- Christie approved protective safety clothing if you are working with the lamp
- Lamp
- Lens cleaning tissue and solution

2.3 Projector Components

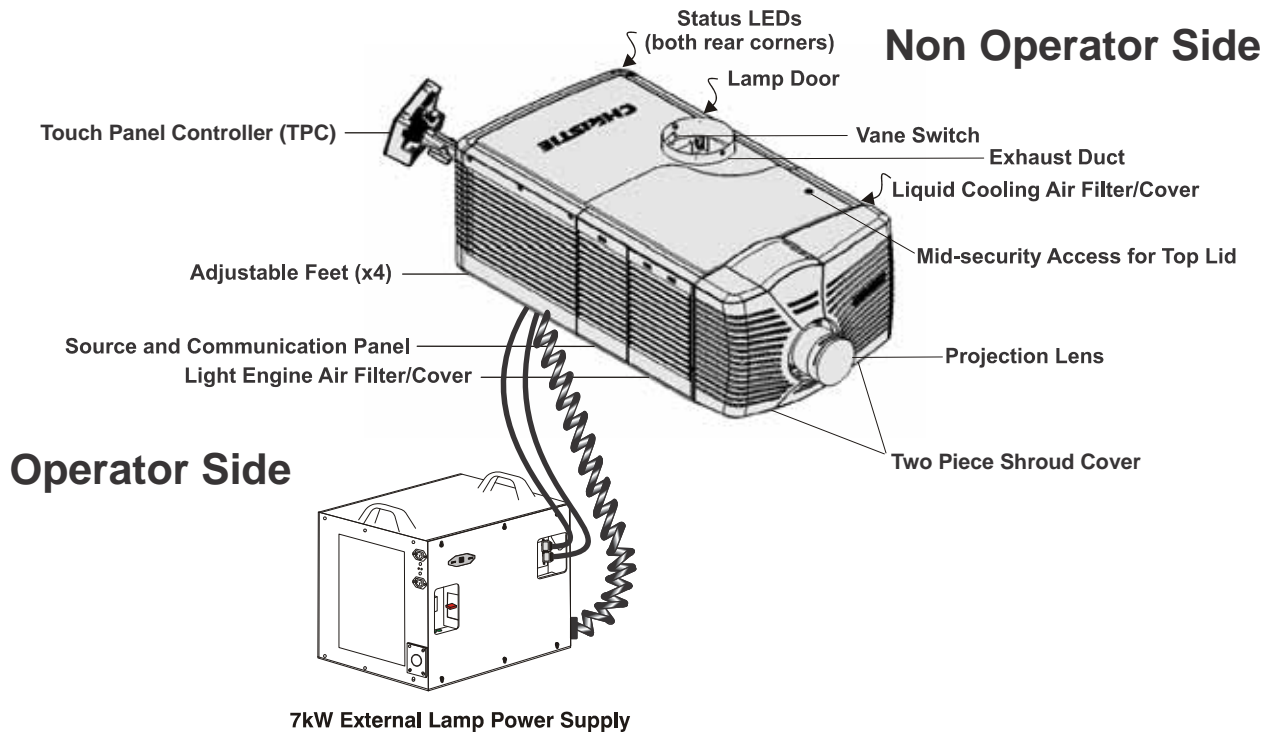

Figure 2-1 Projector Overview

Air Filter Cover and Air Filter

The air filter filters the intake air before it circulates in the front compartment to cool the main electronics. See [Section 6.11 Replace the Light Engine Air Filter](#).

Manual Douser Override

Closes the douser. Closing the douser rotates a shutter blade in front of the lamp and reduces lamp power to 2kW to conserve lamp life. The override switch is meant for emergency use only.

Exhaust Duct and Vane Switch

Extracts heated air from the lamp compartment. The vane switch inside the rigid port monitors the amount of airflow. See [Section 2.1 Site Requirements](#).

Adjustable Feet

Adjusts the tilting angle of the projector.

Lamp Door and Lamps

Provides access to the lamp. The lamp door must remain closed and locked for normal operation. Lamp replacement should only be performed by qualified technicians.

The projector is designed to operate with 2.0kW, 3.0kW, 4.5kW, and 6.0kW lamps.

LED Status Indicators

Provide information about the status of the projector. See [Section 5.3 Using the Touch Panel Controller \(TPC\)](#) for information about projector status.

Motorized Auxiliary Lens Mount (MALM)

An optional auxiliary lens mount can be installed adjacent to the primary lens mount to provide motorized positioning of a 1.25x Anamorphic lens or a 1.26 Wide Converter lens in front of the primary lens. The Wide Converter lens “zooms” the image from flat to scope image formats. The Anamorphic lens horizontally spreads the image back into its wider 2.39:1 “scope” image and is most typically used on larger screen sizes.

Projection Lens

A variety of lenses can be used with the D4K35.

RS-422 Connector

Connects the motorized lens mount to the projector.

Security Locks

Prevents unauthorized access to projector components.

Shroud

Covers the motorized lens mount assembly. Remove the shroud to install a lens, a MALM, or 3D hardware.

Input Panel

Connects the projector to external devices. You use these faceplates to connect devices.

- **PIB3G** (Projector Intelligence Board) Faceplate Connections:
 - **10Base-T/100Base-TX Ethernet:** Connects the projector to a network.
 - **GPIO:** Connects the projector to external Input and output devices. See [3.3 Connect Devices to the GPIO Port](#) for GPIO pinouts.
 - **DVI-A / DVI-B:** Connects the projector to video and graphics sources. These are single-link ports for single-link cables and connectors.
 - **3G-SDI-A/3G-SDI-B:** Connect a variety of high-definition sources to these SMPTE 292M/425 bit serial standard interface BNCs. The connectors can be used together to deliver Dual Link HD-SDI following the SMPTE 372M standard. Also supports quad link 4K sources (refer to supported inputs), with each connector input a quarter’s image at 2K resolution in SDI format.
 - **SCCI:** A Simple Contact Closure Interface (SCCI) port that uses a simple dry contact closure to turn the lamp on or off or to open or close the douser. See [3.2 Connect Devices to the SCCI Port](#) for SCCI pinouts.
 - **RS232 ICP:** Connects a projector to a computer for direct DLP communication.
 - **RS232 PIB3G:** Connects the projector to Christie accessories or third-party automation equipment.
 - **Emergency Start:** Starts the projector, turns the lamp on, and opens the douser when the Touch Panel Controller is unavailable or disconnected. Press and hold this button, to close the douser and turn the lamp off; the power remains on.
 - **Reset:** Resets the projectors electronics. After the projector restarts, the projector returns to the standby mode.

- **3D:** Connects the projector to 3D products, such as MasterImage or Real D for polarizing and de-ghosting 3D content during projection.

ICP Faceplate Connections

The ICP board provides the image processing electronics for the projector. The ICP faceplate includes a number of LEDs that are only functional when the projector is in full power mode.

- **REGEN:** (Regulators Enabled) Indicates the presence of the internal regulator enable signal. When illuminated BLUE the internal regulators are enabled. When OFF, not enabled.
- **SOFTST:** (Software State) Indicates the state of the software application. When OFF, in a Fail state (0). When RED, in a Fail state (1). When YELLOW, in a Fail state (2). When GREEN, status OK.
- **OSST:** (Operating System State) Indicates the state of the operating system. When OFF, in a Fail state (0). When RED, in a Fail state (1), When YELLOW, in a Fail state (2). When GREEN, status OK.
- **FMTST:** (FMT FPGA State) Indicates the configured state of the FMT FPGA. When RED, unable to configure FPGA with Main or Boot application. When YELLOW, in Boot application. When Green, in Main application.
- **ICPST:** (ICP FPGA State) Indicates the configured state of the ICP FPGA. When RED, unable to configure FPGA with Main or Boot application. When YELLOW, in Boot application. When Green, in Main application.
- **Port A / Port B:** Indicates the status of the ICP input port A or B. When OFF, no source is present. When GREEN, active source present.

Touch Panel Controller (TPC)

The TPC is a touch-sensitive screen that you use to control the projector. It is mounted on the rear of the projector and you can use the flexible connection to adjust the viewing angle. In general, the TPC provides users with a means for monitoring operation and status of the projector. You typically use the TPC to turn the lamp on or off, select an input device, and view status information.

You can install the TPC on a wall near the projector, or you can use the optional extension cable to control the projector from a maximum distance of 100 feet.

Lamp Power Supply (LPS)

The Lamp Power Supply (LPS) (P/N 129-003104-XX) is an external component for the D4K35 projector. To connect it to the projector, you use a twisted-pair high power lamp cable assembly, a RS-232 serial cable and an Interlock (Lamp Enable) cable. You can install the LPS in the optional rack stand with the projector.

The LPS provides DC power for 2.0, 3.0, 4.5 and 6.0kW lamps. A breaker on the side of the LPS acts as a power switch, and provides protection against over-current conditions of 50A or more. If a fault occurs or excessive voltage is detected, the breaker automatically switches OFF to prevent damage.

The LPS includes two AC power outlets that you can use to power projector electronics or an approved extraction unit. Do not use these outlets to power other devices. The outlets must be wired accordingly for the local region.

2.4 General Installation Safety and Warning Guidelines

⚠ WARNING QUALIFIED TECHNICIAN REQUIRED for all installations. This product must be installed in a restricted access location.

⚠ WARNING Never operate the projector without all of its covers in place.

⚠ WARNING The projector uses a high-pressure lamp that may explode if improperly handled. Always wear manufacturer approved protective safety clothing (gloves, jacket, face shield) whenever the lamp door is open or when handling the lamp. Only qualified technicians should install projector lamps.

⚠ WARNING To prevent the projector from tipping unexpectedly, you must install the safety strap on the rear of the projector.

⚠ WARNING Four or more people are required to safely lift and hand-carry one projection head a short distance. Recommend removing the lamp before transporting the projector.

⚠ CAUTION Keep the projector level when you lift or transport it. Avoid tilting the projector to the right. This can introduce an air bubble into the coolant hoses that can result in an air lock and the overheating of the projector.

⚠ CAUTION Perform a automatic LampLOC™ adjustment when you move, level, or install a new lamp in the projector.

2.5 Position the Projector and lamp Power Supply

1. Position the projector at an appropriate throw distance (projector-to-screen distance) and vertical position. Ideally, center the projector with the theatre screen. If space is limited, aim the projector slightly off-center. This increases side keystoneing, but reduces the horizontal lens offset required.

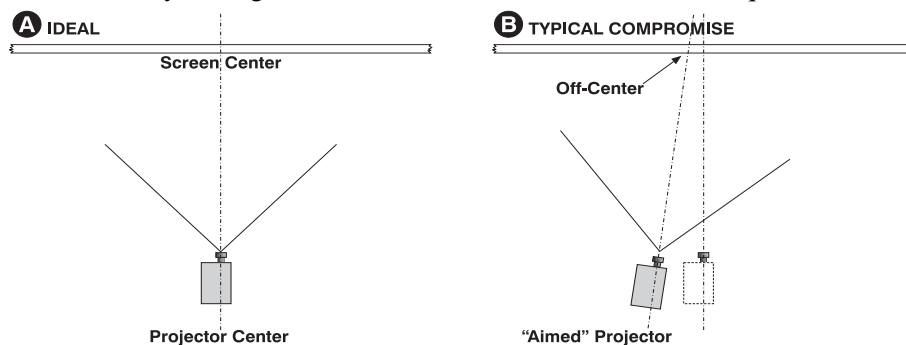

Figure 2-2 Position the Projector

NOTE: Keep the projector lens as parallel to the screen as possible, even if significantly above the screen center. When a particularly short throw distance combines with a very wide screen, you may have to forfeit some aim and stay more parallel to the screen. In such cases, some lens offset can reduce the keystone distortion.

2. Locate the lamp power supply so that its cables can reach the left side of the projector.

3. If you are using an optional rack stand assemble the rack stand using the instructions provided with the rack stand. **NOTES: 1)** For better access, wire the LPS before installing it into the rack stand. **2)** Use the hold down clamp (P/N 116-100101-01) when securing the projector to the rack stand.
4. Install and secure the lamp power supply (LPS) in the rack stand:
 - a. Remove the right (the operator's side) panel of the rack stand.
 - b. Remove cross bar.

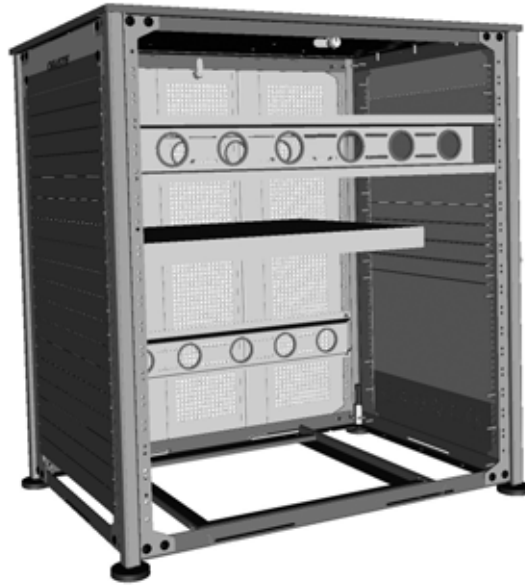

Figure 2-3 Side View of Rack Stand

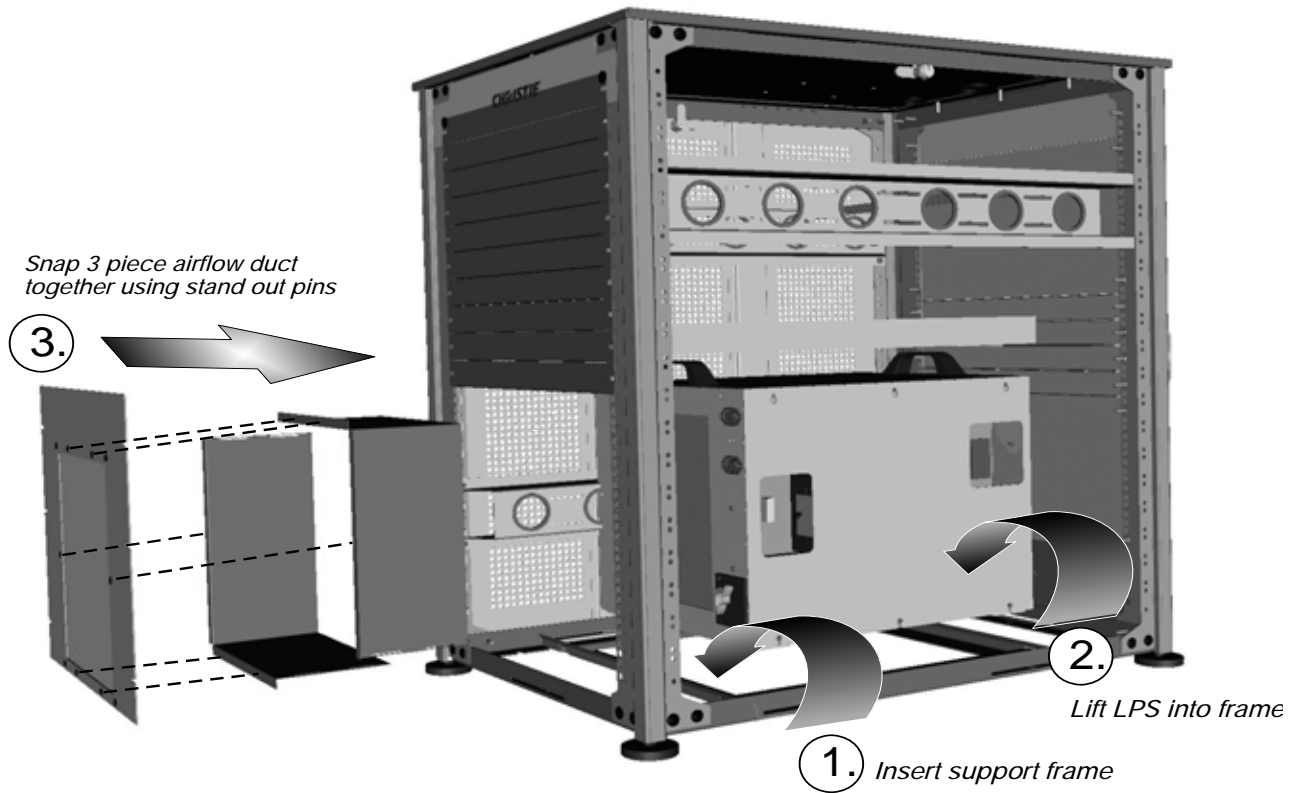

Figure 2-4 Steps to Installing LPS

- c. Insert the LPS support into the rack stand and align the pins with the holes.
- d. Lift the LPS into the frame.
- e. Remove the bottom 10 panels from the back of the rack stand.
- f. Assemble the three piece airflow duct (supplied with LPS). See **Figure 2-4**. First snap the 2 “L” shaped parts together, and then snap this into the 6 stand out pins of the third piece (flat panel)..
- g. Position the airflow duct directly behind the LPS.
CAUTION! Do not install any components in front of the lamp power supply that will restrict airflow.. See **Figure 2-5**.
- h. Insert airflow duct into rack stand from the outside. See **Figure 2-4**.
- i. Secure airflow duct to rack stand using screws from the rack stand panels.
- j. When installing other components in the rack stand allow at least 2” clearance above the LPS handles for ease of servicing. See **Figure 2-5**.
- k. Wire all components within the rack stand and replace the side panel.
- l. Twist LPS cable 12 twist/meter.

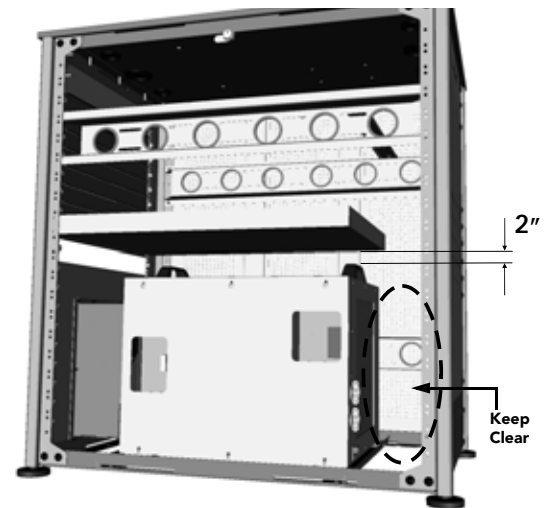

Figure 2-5 Steps to Installing LPS

2.6 Secure the Projector

⚠ WARNING Use of the projector's rear safety strap is **MANDATORY** to prevent it from tipping. Secure the strap between the projector and the optional rack stand or any other surface it is mounted to.

2.7 Adjust Tilt and Level the Projector

⚠ WARNING The projector's rear safety strap must be in place before you adjust the projector's feet.

⚠ WARNING DO NOT over-extend the feet. Make sure several threads are engaged into the projector's baseplate.

The D4K35 lens should be centered and parallel with the screen. This orientation ensures ideal lens performance with minimal offset. If this position is not possible (such as when the projector is significantly higher than the center of the screen), it is better to rely on offset rather than extra tilt.

Use a protractor to measure the degree of screen tilt and then extend or retract the projector feet to match this angle.

NOTES: *The front-to-back tilt of the projector must not exceed 15°. This limit ensures safe lamp operation and the proper positioning of the liquid cooling reservoir.*

To adjust the vertical or horizontal position of the projector, extend or retract the adjustable feet on the bottom of the projector by rotating them. Once the required adjustment is made, tighten the lock nut. (**Figure 2-6**)

If you need to adjust the vertical or horizontal position of the projector beyond what the standard feet allow, you can install two 6 inch extension rods to increase the amount of adjustment. To install the extension rods safely:

1. Prop the rear of the projector up to access and remove the two rear feet. This can be done by one person holding the back end of the projector up slightly so another person can unthread the feet OR by propping up the back of the projector with a sturdy object.
2. Add the extension rods to the standard feet.
3. Thread the extended feet into the projector's baseplate. Adjust the feet until the desired tilt is achieved.
4. Lock the feet in place by turning each lock nut until it fits tight against the projector.

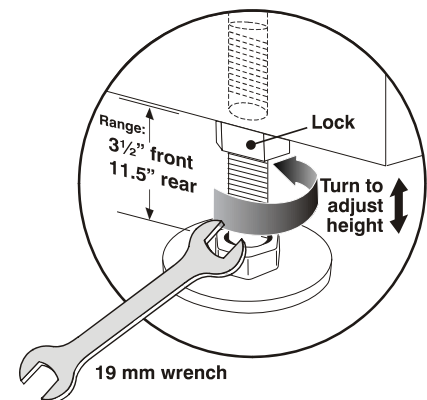

Figure 2-6 Adjust Feet

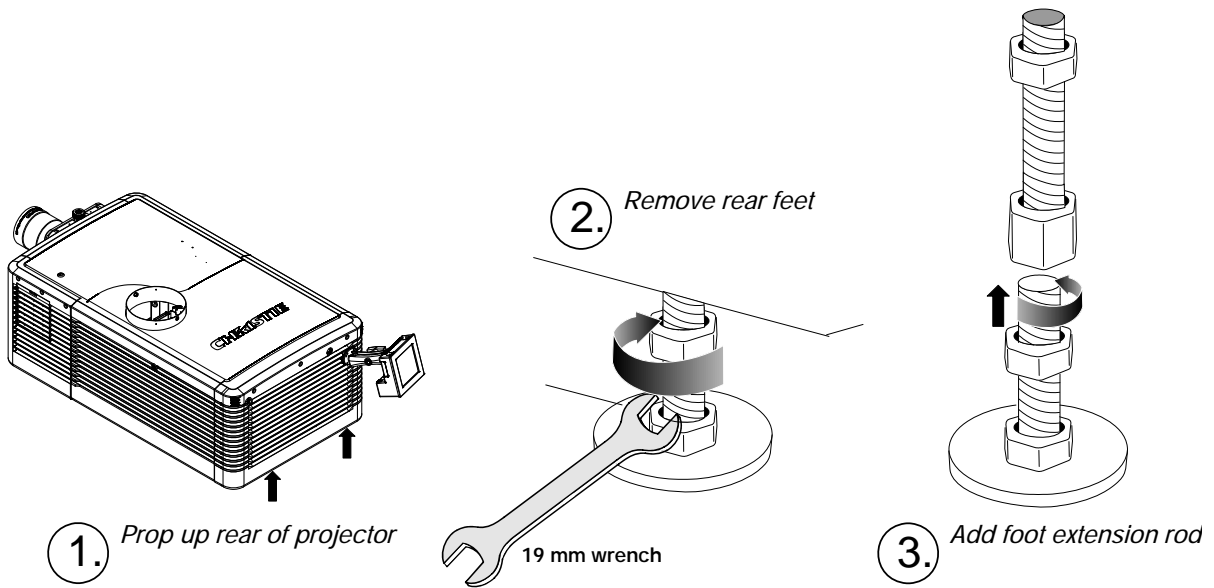

Figure 2-7 Using the Foot Extension Rods

2.8 Install the Touch Panel Controller (TPC)

1. Loosen the mounting arm just enough for the end to fit over the ball joint located on the rear panel of the projector.

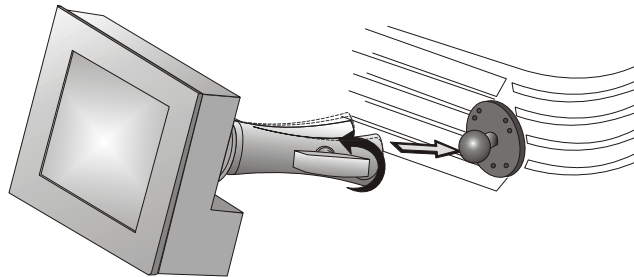

Figure 2-8

2. Tighten the mounting arm until it fits tightly on the joint.

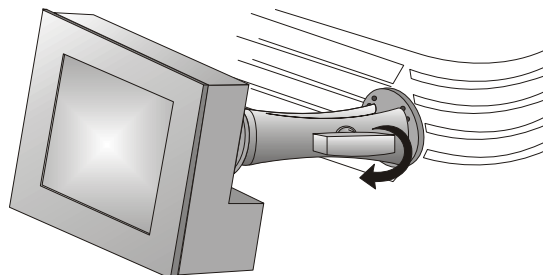

Figure 2-9

3. Connect the cable from the TPC to the connector on the rear panel of the projector.
4. Adjust the angle of the TPC.

2.9 Connect External Exhaust Ducting

Connect the existing outside-venting ductwork to the 8 inch diameter exhaust port on the top of the projector. Confirm that there are no obstructions or bends in the ducting, all air intakes are free of obstructions, and the vane switch at the exit duct moves freely.

The pre-installed outside-venting duct should be rigid at the projector and must also include a heat extractor and blower that maintains a minimum of 450 CFM* when the projector is operating at less than or equal to 25°C ambient and less than 3,000 feet, when measured at the projector exhaust opening.

! WARNING

- ***600 CFM is required in projection rooms with an ambient temperature above 25°C or located at an elevation greater than 3000 feet above sea level.**
- **At minimum, a 10" long, strong metal duct must be installed at the projector to prevent glass shards from exiting the duct in the event of a lamp explosion.**

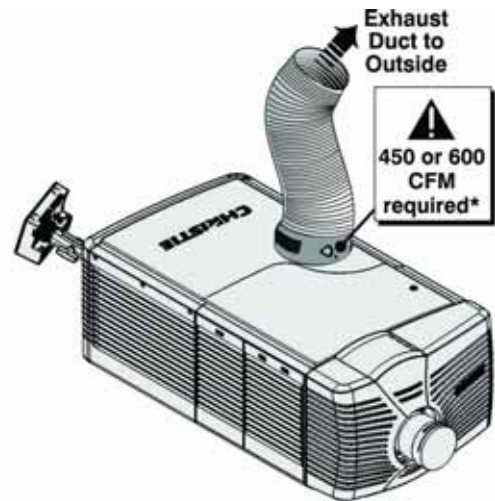

Figure 2-10 Connect Exhaust Ducting

2.9.1 Determine the Projector Exhaust CFM Value

Use an airflow meter to measure the ft/min or ft/sec at the rigid end of the open exhaust duct that connects to the projector. Take the measurement at the very end of the duct without the projector connected. Use this formula to determine the CFM value for the projector:

$$\text{Measured linear ft/min} \times 0.35 = \text{CFM}$$

Table 2.1 Airflow Requirement

Lamp Type	Min. Airflow (CFM) Required
2.0 kW	450 CFM*
3.0 kW	450 CFM*
4.5 kW	600 CFM
6.0 kW	600 CFM

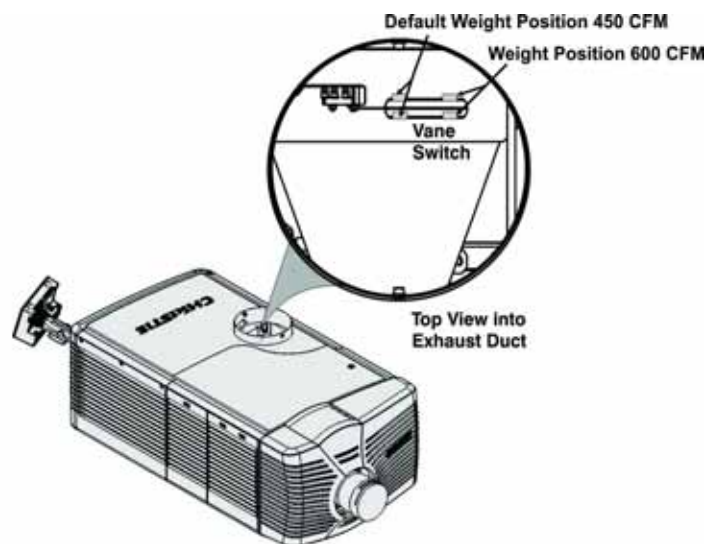

Figure 2-11 Exhaust Duct Vane Switch

*600 CFM is required in projection rooms with ambient temperature above 25°C or elevation (above sea level) greater than 3000 feet.

Add an extractor or a booster if there is insufficient airflow. Do not mount the extractor on the projector as this may introduce some vibration into the image. **NOTE:** *To prevent the projector from overheating or becoming unsafe, an alarm sounds if the duct is obstructed or a fan fails. It is recommended that you regularly verify that the exhaust is functioning correctly.*

⚠ CAUTION Never disable the vane switch. Attempting to operate the projector with inadequate airflow can result in dangerous overheating of the projector.

2.10 Remove the Shroud

To access the MLM and lens, you need to remove one shroud. You must remove the second shroud when you use a Motorized Auxiliary Lens Mount or plug AC power cord into front face of the projector.

1. Using finger pressure, push down on the locations specified by the red arrows in the diagram.
2. Carefully slide the shroud sideways and forward away from the MLM and lens.
3. Place the shroud cover on a clean surface to prevent scratches.

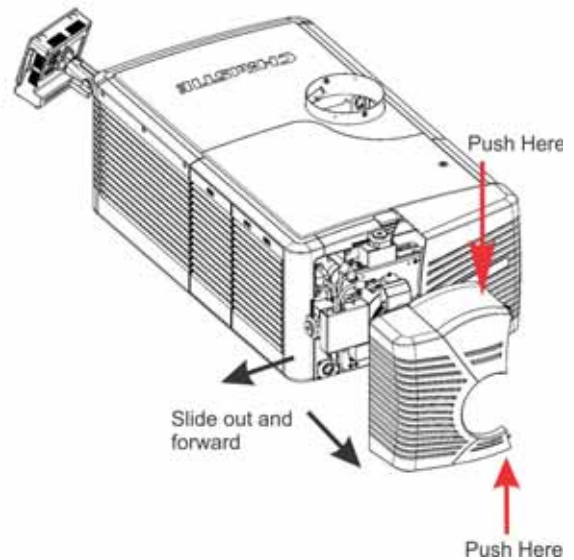

Figure 2-12 Shroud Removal

2.11 Install the Primary Lens

The lens seals the projection head, preventing contaminants from entering the main electronics area. Do not operate the projector without a lens installed. Install a lens plug when you install or transport the projector.

⚠ CAUTION Never operate a projector without a lens.

⚠ WARNING To prevent a collision between the projection lens and the Motorized Auxiliary Lens Mount (MALM), move it to the OUT position before you calibrate the lens or perform reset functions. Keep your fingers and other body parts away from the moving parts in the projector. Motors and fans may start without warning. Tie back long hair, remove jewelry and loose clothing before manually adjusting the projector.

Installing a Primary Lens:

NOTE: **1)** Make sure the zoom ring is against the front of motor mount for lenses: 1.6-2.4:1, 1.8-3.0:1, 2.15-3.6:1. **2)** Make sure the zoom ring is against the back of motor mount for lenses: 1.45-2.05:1, 1.25-1.83:1. **3)** All other lenses: Leave a gap between the rotating zoom section of lens and motor mount.

1. Unpack the zoom motor kit.

2. Use a flathead screwdriver to install the zoom motor mount onto the lens with screw clamp.

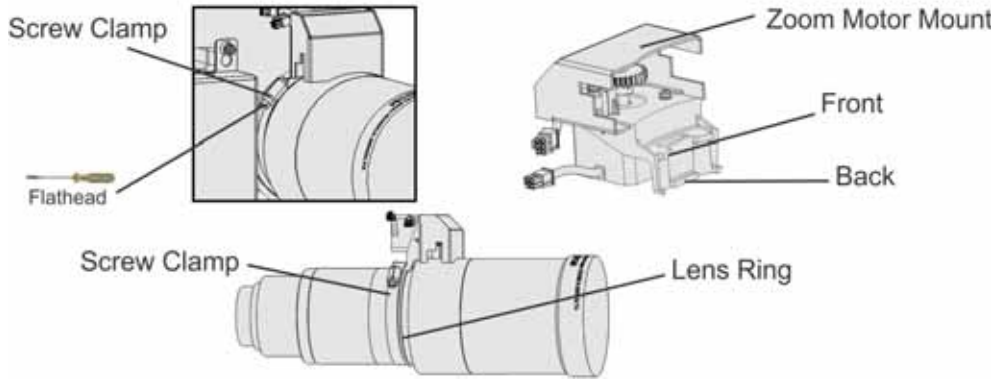

Figure 2-13

3. Remove the cover from the zoom motor mount with phillips screwdriver. Keep the hardware and cover.

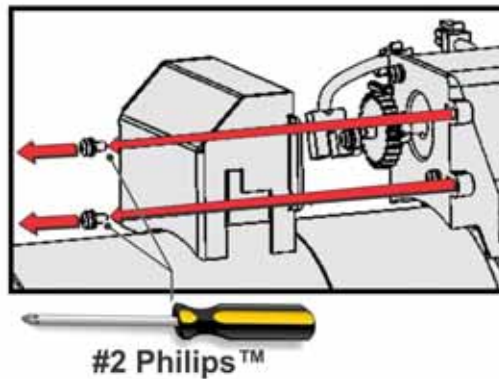

Figure 2-14

4. Install zoom gear ring and adapter onto lens.

NOTE: 1) Use small adapter for lens 1.8-3.0. **2)** Use large adapter for lens 1.45-2.05, 2.15-3.6, 1.25-1.83:1 **3)** All other lenses do not need an adapter.

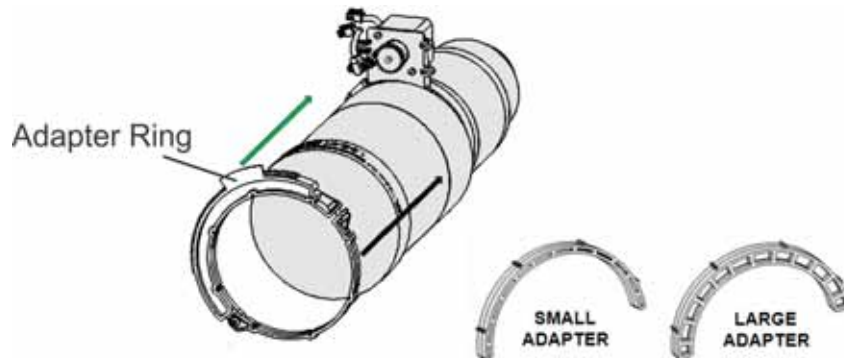

Figure 2-15

5. Verify that there is full travel of the gear ring, and the alignment of the sensor is correct.

NOTE: There must be a small gap between the gears to prevent binding. To ensure there is a gap, loosen the screws and readjust the gap. Tighten the screws when you have completed the adjustment.

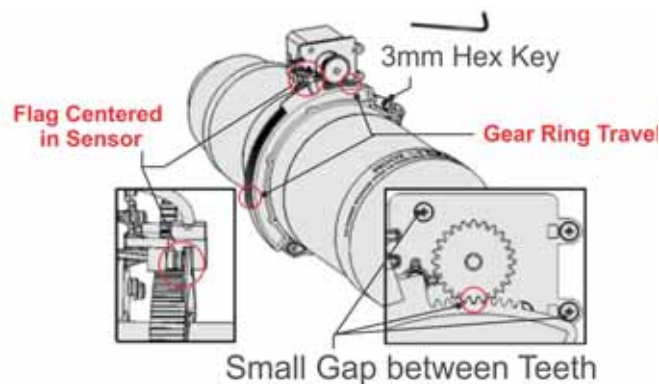

Figure 2-16

6. Turn the lens clamp to the OPEN position on the MLM and fully insert the assembly straight into the lens mount opening without turning. When the lens is fully inserted it is seated properly within the lens mount and the aperture is installed correctly.

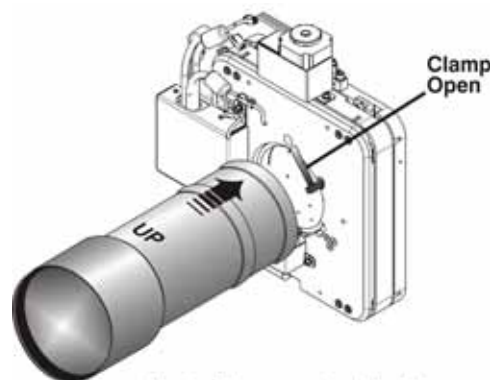

Figure 2-17

7. Install the cover with the screws.

NOTE: Make sure the cover is between the mounting tabs.

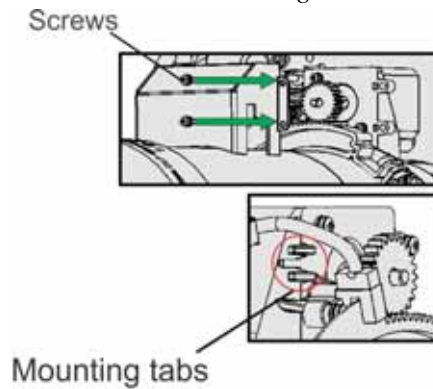

Figure 2-18

8. Connect the harness wires.

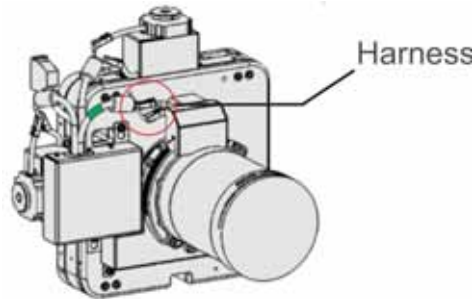

Figure 2-19

9. Position the lens clamp DOWN to lock the lens assembly in place.

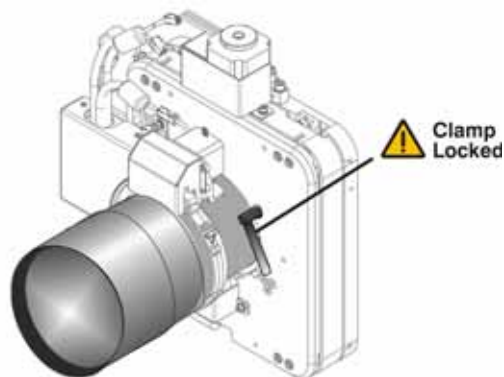

Figure 2-20

10. Calibrate the lens. See [Figure 2-20](#) for details.
11. Install the shroud.
12. Install the shroud.

2.12 Install the Optional Anamorphic Lens

1. Install the M-MALM according to the instructions provided with the kit. Ensure the primary lens is optimized first for best optical alignment, offset and boresight.
2. Loosen the holding clamp on the auxiliary lens mount and adjust rotation of the whole anamorphic lens so the image remains perfectly square with anamorphic in and out.
3. Adjust location of anamorphic lens so the image does not shift left or right with the anamorphic lens IN and OUT.
4. Adjust location of anamorphic lens so the image passes through the center as much as possible without vignetting or reducing side or corner brightness, especially in wide angle projection.
5. With the anamorphic lens not in place, re-focus the primary lens. The goal is good focus at center and on all sides. Now add the anamorphic lens and check focus again.
6. If center-to-edge horizontal focus in the image needs improvement, rotate the focus barrel.

2.13 Install the Optional Wide Converter Lens

1. Install the Auxiliary Lens Mount and WCL according to the instructions provided with the kit. Ensure the primary lens is optimized first for best optical alignment, offset and boresight.
2. Adjust the vertical and horizontal position of the WCL to align it with the already adjusted prime lens.
3. Adjust pitch, either up or down to equalize the top and bottom clearance to the prime lens barrel.
4. Adjust yaw so the clearance between both lens barrels is equal from side-to-side.

2.14 Install The Lamp

⚠ DANGER This procedure should only be performed by a Christie accredited technician. High-pressure lamp may explode if improperly handled. Always wear approved protective safety clothing whenever lamp door is open or when handling the lamp.

1. If the projector is operating, turn it off and allow it to cool a minimum of 10 minutes.
2. Turn the breaker switch for the projector off.
3. Disconnect the projector from AC power.
4. Put on your protective clothing and face shield.
5. Use the security key to open the lamp door and access the lamp cooling compartment. Do not place heavy objects on the open lamp door.
6. Install the anode yoke assembly. Use this table to determine the correct position of the anode yoke assembly:

Table 2.2 Lamp Types Available for D4K35 and Anode Yoke Position

LAMP	TYPE	ANODE YOKE POSITION
2.0 kW and 3.0kW	CDXL-20 CDXL-30 CXL-20* CXL-30	Move the lamp cradle to the rear position, which is approximately 1" closer to the reflector. *NOTE: A lamp adapter kit must be used with the CXL-20 lamp.
4.5 and 6.0kW	CDXL-45 CDXL-60	Move the lamp cradle as far forward as possible (position closest to igniter)

7. Install the lamp. See [Section 6.9 Replace the Lamp](#) for lamp replacement instructions.

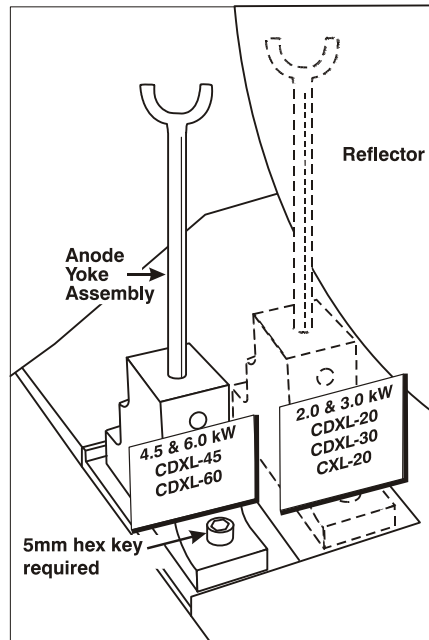

Figure 2-21 Anode Clamp Location

2.15 Connect Lamp Power Supply (LPS)

⚠ CAUTION When connecting the LPS and the Igniter the black (-) power cable must be connected to the cathode lead and the red (+) power cable must be connected to the anode lead. Reversing the connections can damage the projector.

⚠ WARNING You must connect the LPS to the projector before you connect it to AC power.

⚠ WARNING 1) Certified electrician required. 2) Ground (earth) connection is necessary for safety. Never compromise safety by returning the current through the ground. 3) Connect ground FIRST to reduce shock hazard.

⚠ WARNING Use an appropriate strain relief connector on the AC supply cable to prevent the cable from rubbing against the LPS knockout plate and becoming damaged

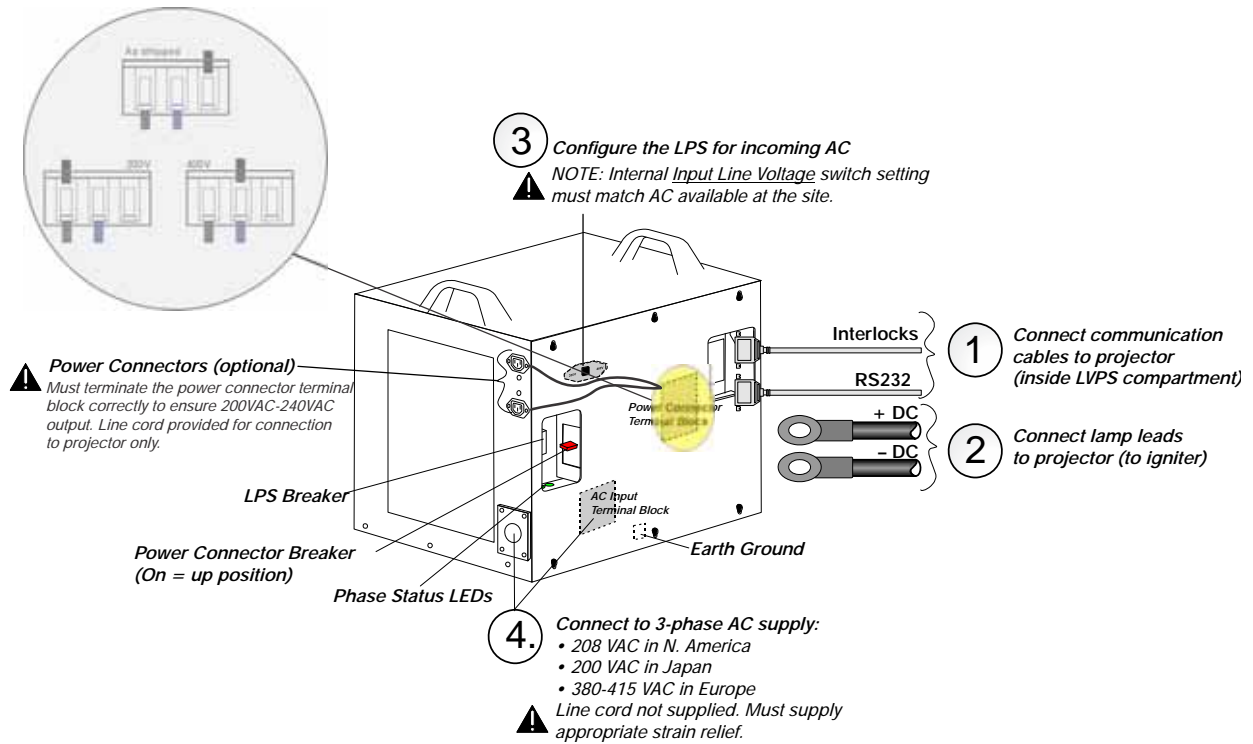

Figure 2-22 Connect LPS

1. Connect the LPS Communication Cables:
 - a. Remove the 2 cover plate thumbscrews from the projector’s baseplate in the LVPS compartment.
 - b. Connect one end of the RS232 cable to the port on the LPS labeled RS232. Route the cable up through the opening in the projector’s baseplate into the LVPS compartment. Connect the other end of the RS232 cable to the port labeled RS232 in the LVPS compartment.
 - c. Connect one end of the Interlock cable to the port on the LPS labeled Interlocks. Route the cable up through the opening in the projector’s baseplate that you ran the RS232 cable. Connect the other end of the Interlock cable to the port labeled Interlock in the LVPS compartment.

2. Connect the Lamp Leads:
 - a. Open the LVPS access door and use a 3 mm driver to remove the four M4 hex head screws from the safety cage front panel. Lift the front panel over the igniter.
 - b. Loosen the 6 screws to remove the LPS side panel.
 - c. Route the cables through the strain reliefs in the LPS cover.
 - d. Connect the positive (+) and negative (-) lamp leads to the terminals on the LPS.
 - e. Tighten the strain reliefs.
 - f. Route the positive and negative leads from the LPS through the two strain reliefs in the projector base-plate.

⚠ CAUTION When connecting the high current lamp leads between the LPS and the igniter make sure the black (-) power cable (cathode lead) is securely connected with the washers and lock washers properly in place and tighten to 175 inch-lbs, 14 ft-lbs or 20Nm at both ends as to prevent them from coming loose.

- g. Connect the negative (-) black lamp lead to the negative (-) igniter terminal, left terminal. Connect the positive (+) red lamp lead to the positive (+) igniter terminal, right terminal. **CAUTION!** *When tightening the positive and negative leads, do not tighten to the point that the brackets start to bend. Use an adjustable wrench to support the brackets when tightening.*
 - h. Tighten the strain reliefs.
 - i. Replace the igniter safety cage.
3. Move the AC Input Line Voltage switch in the upper-left corner of the LPS to the left if you are using a 200 VAC supply, or right if you are using a 400 VAC supply.
4. Use an AC Input Terminal Block that is correct for your region to connect the AC directly to the LPS. **CAUTION!** *Use an appropriately sized strain relief connector with the knockout plate provided to ensure adequate environmental sealing and to prevent the cable from accidentally being torn out.*
 - **For North America, Japan, Korea and most of Central/South America (200-230 VAC):**
Wire Phase 1, 2, 3 and Ground
 - **For Europe and China (380-415 VAC):**
Wire Phase 1, 2, 3, Neutral and Ground

- Using the line cord provided with the LPS, connect one end into the power connector labeled “Projector ONLY” and the other end into the plug on the projector’s front bezel (**Figure 2-23**).

⚠ WARNING DO NOT access power for the projector directly from the building electrical source.

WARNING! *If you choose to use the power connectors to power the D4K35 Projector and/or the Extraction Unit, you must terminate the power connector terminal block correctly to allow 200VAC-240VAC output. These connectors are controlled with the power connector breaker. For details, refer to the Interconnect Drawing provided with your projector and to [Figure 2-22 Connect LPS](#).*

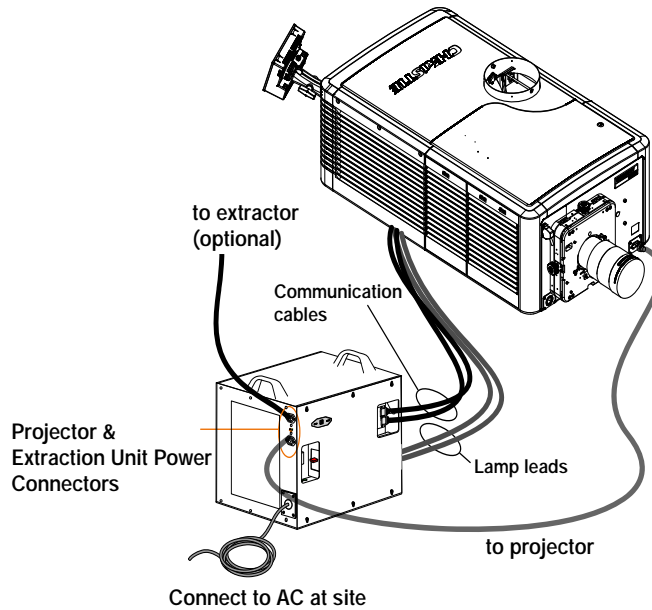

Figure 2-23 LPS Connection

- Turn LPS Breaker ON.
- If you are using the extraction unit and projector power connectors, turn them on.
- Connect AC from the site to the projector (plug located on front bezel, bottom-right corner).(**Figure 2-24**)

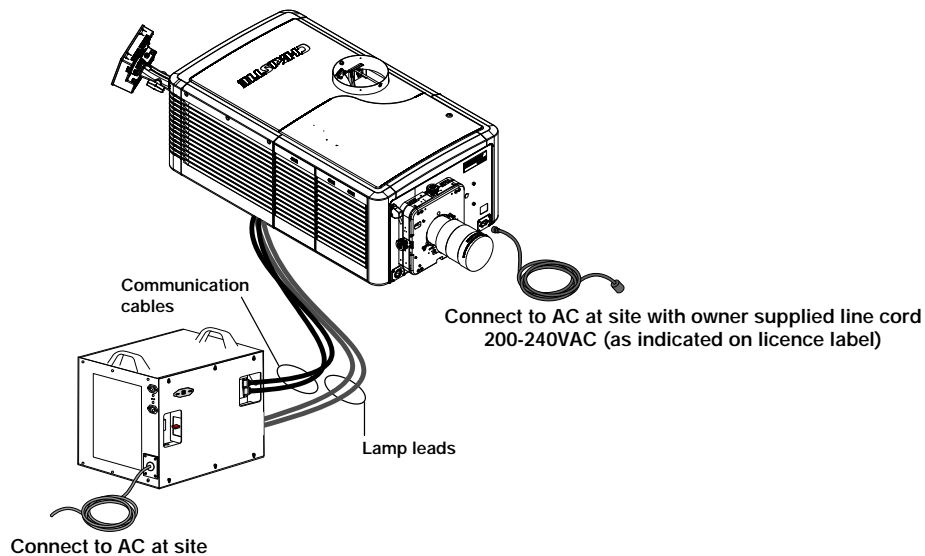

Figure 2-24 Connection to AC

2.16 Connect the Projector to an Optional Uninterrupted Power Supply

A UPS allows the projector head electronics to remain operable during a power failure.

It is recommended that you install a 200-240VAC UPS in-line between the LPS and the projector. To connect the projector to a UPS, unplug the LVPS input from the main power and then connect it to the UPS input socket.

⚠ WARNING Do not connect a UPS directly to the projector UPS input.

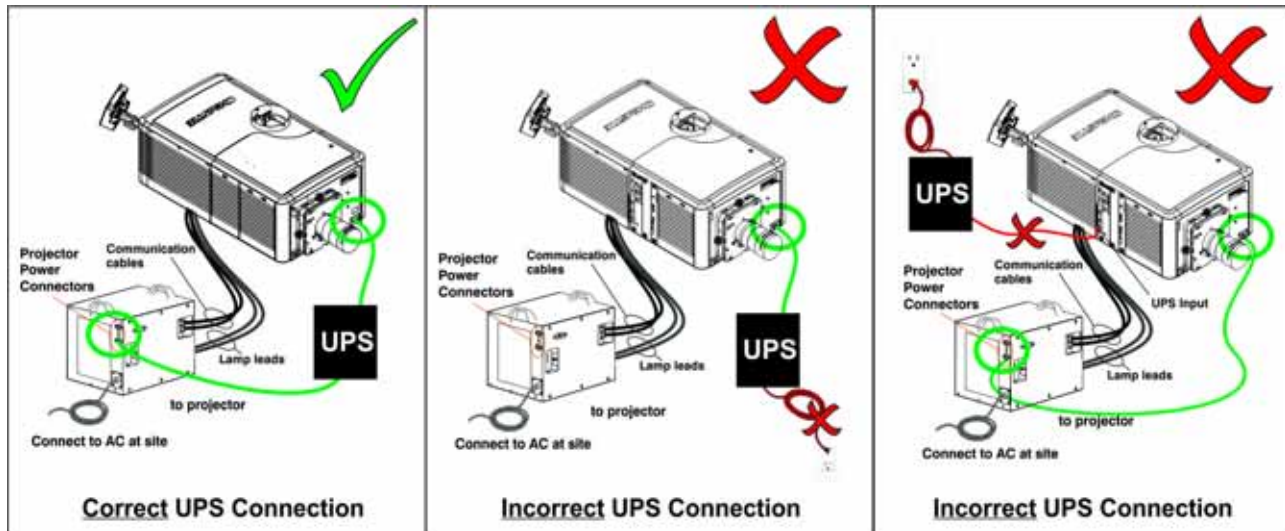

2.17 Connect Sources and Turn the Projector On

After you install the lamp, you can connect external servers and sources. Before you ignite the lamp for the first time, use this procedure to ensure successful communication with input devices.

- Assign the projector a unique IP address and enter a baud rate:
 - Tap **Menu > Administrator Setup > Communications Configuration**.
 - Enter the IP address for the projector in the **IP Address** field.
 - Select a baud rate for the input device in the **Serial Speed (Baud)** list.
- Enter lamp information:
 - Tap **Menu > Advanced Setup > Lamp History**.
 - Tap **Add Lamp**.
 - Complete the fields in the **Add Lamp** dialog.
 - Tap **Save**.
- Tap and hold the green power button to turn the projector on.
- Complete a LampLOC™ alignment on the new lamp:
 - Tap **Menu > Advanced Setup > LampLOC™ Setup**.
 - Tap **Do Auto**.
- Complete an optical alignment to optimize images displayed on screen.
- Adjust optical components if required.

3 Connect Devices to the Projector

This section provides information and procedures for connecting input devices to the projector. You connect input devices to the Projector Intelligence Board (PIB3G) located on side of the projector.

These communication ports are accessible by removing the side source and communication access panel. When connecting devices, route all cables along the channels located on the bottom of the projector and up through the opening in the frame to the communication connection port.

Replace the access panel to ensure server and source connections remain secure.

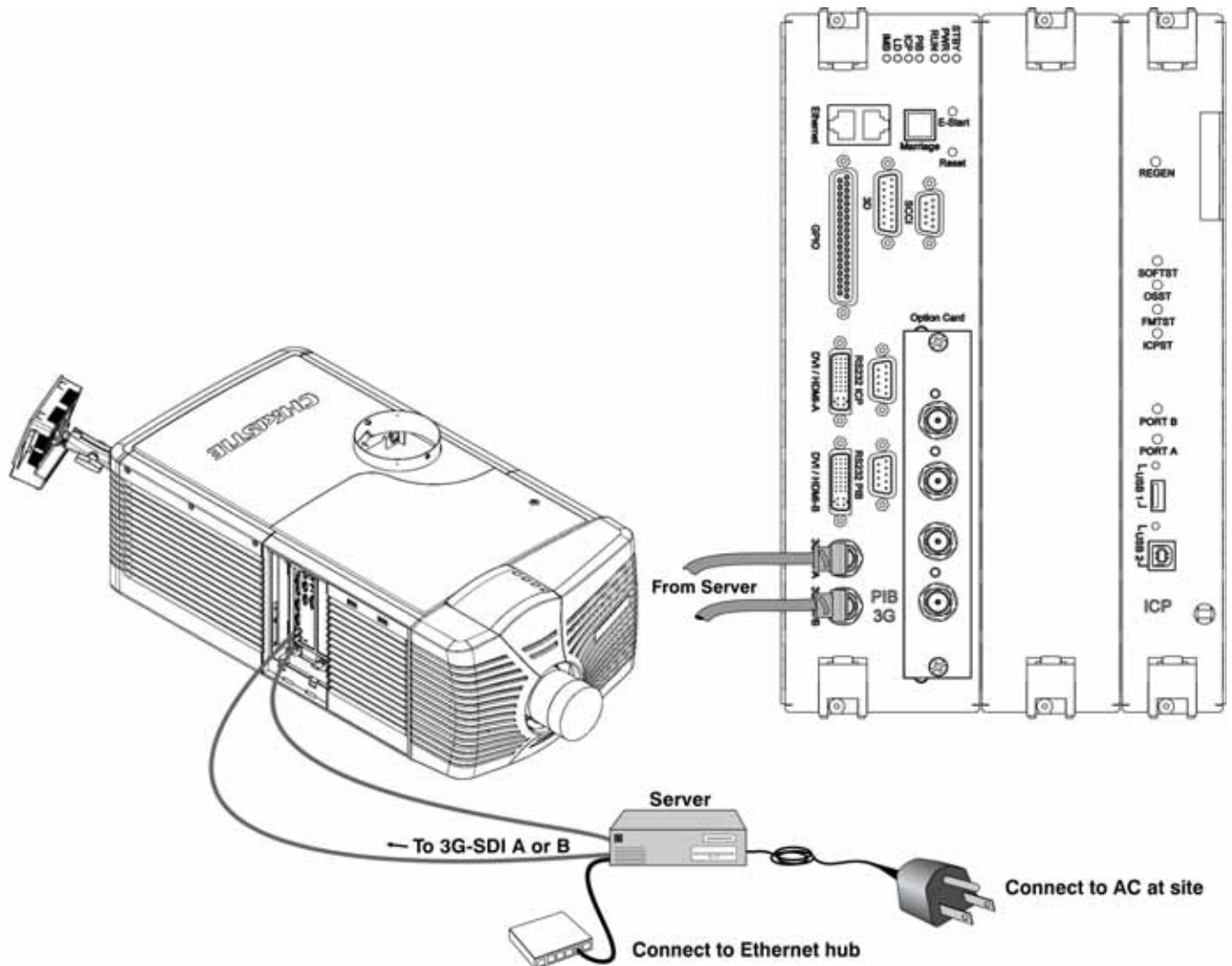

Figure 3-1 Connecting Server Sources

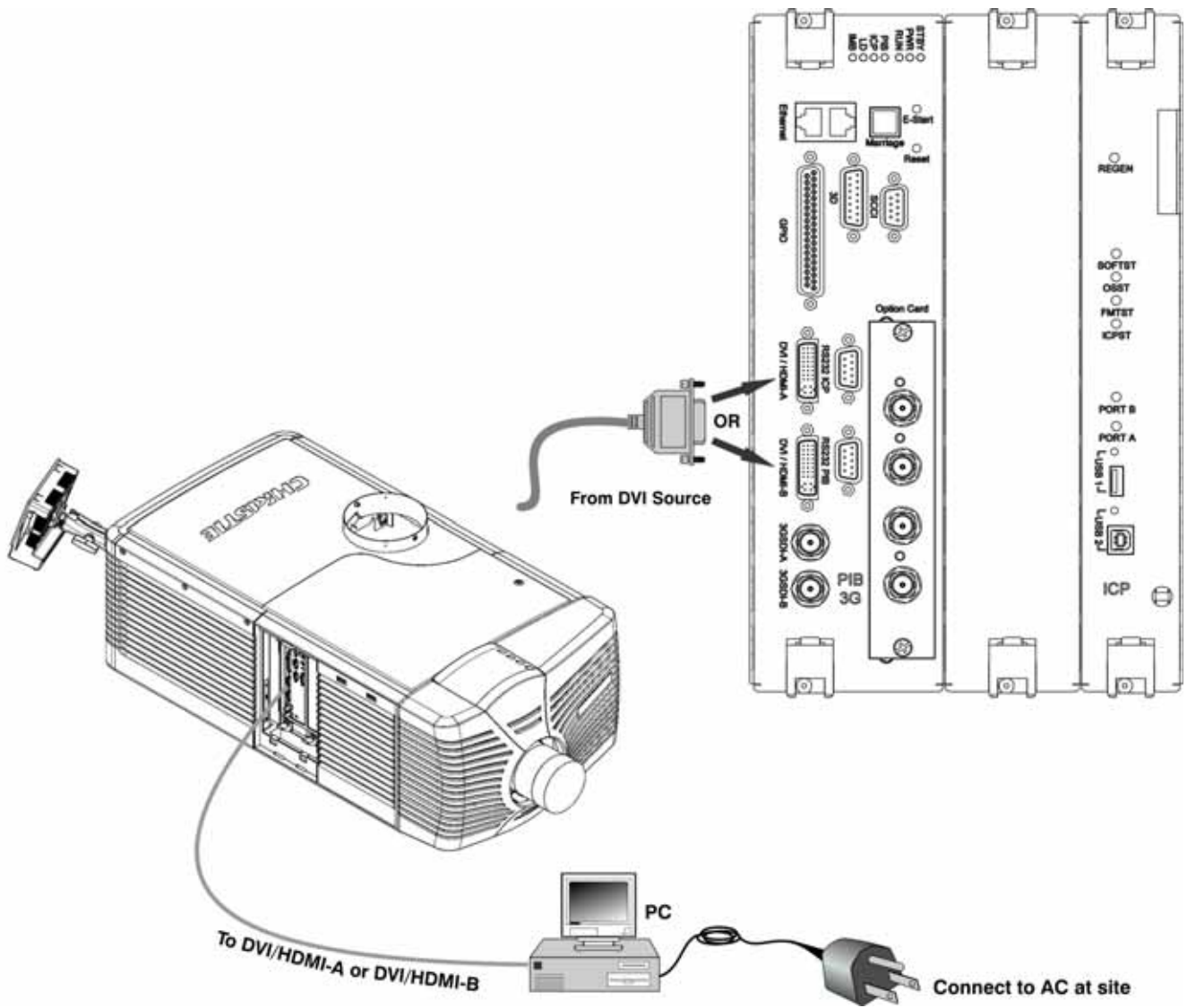

Figure 3-2 Connecting PC Sources

3.1 Connect a Computer or Server

To communicate with the projector from a computer, server or an existing network, connect the equipment to the Ethernet hub or switch.

For applications or equipment utilizing serial communications, use the Christie-proprietary serial protocol to connect to the RS232 PIB3G port on the PIB3G. When using Christie serial protocol over Ethernet connect to port 5000. **NOTICE:** The RS232 PIB3G port located on the PIB3G faceplate utilizes Christie-proprietary protocol and is intended for Christie accessories or automation controllers only.

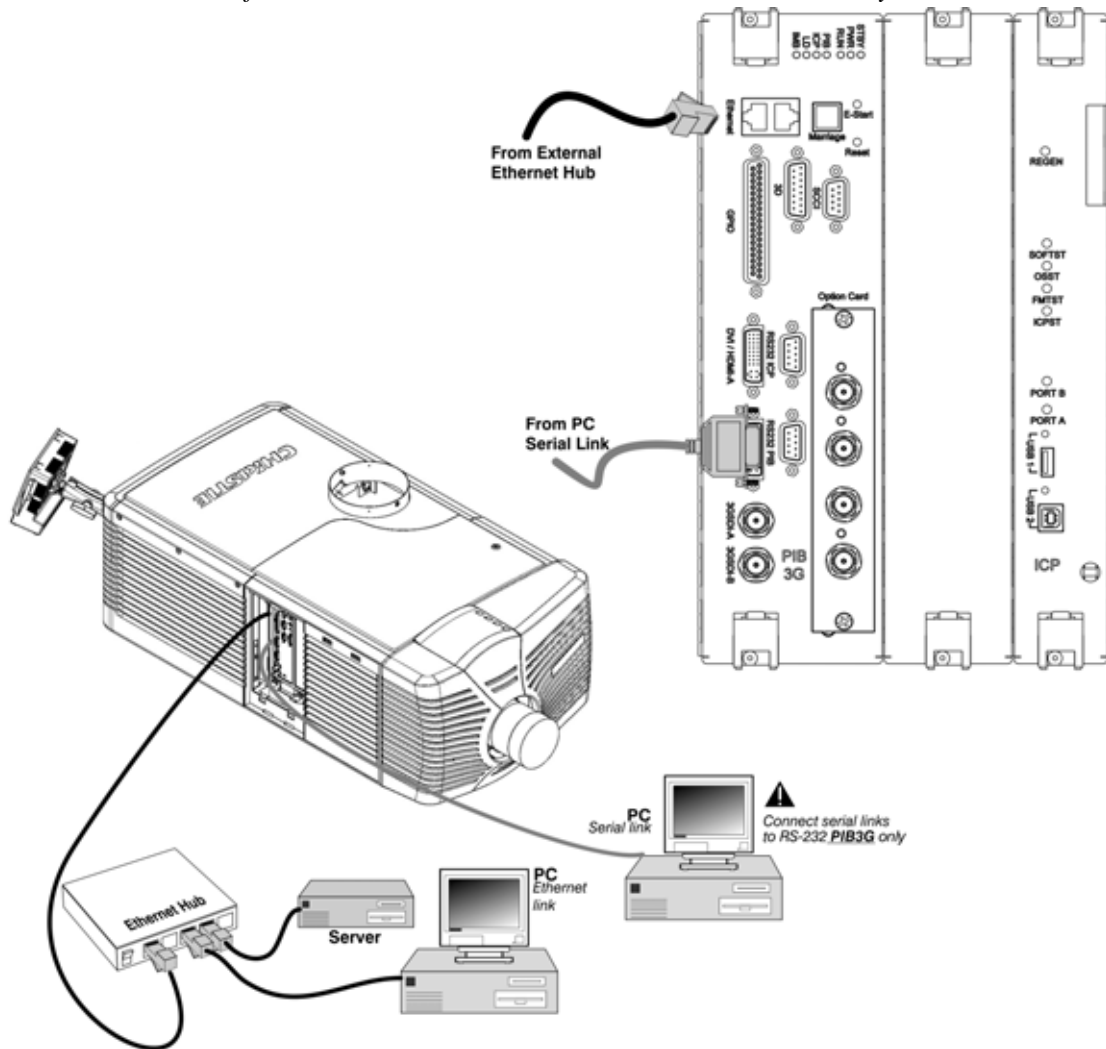

Figure 3-3 Connecting Communications

3.2 Connect Devices to the SCCI Port

The Simple Contact Closure Port (SCCI) port is a DB-9 (male) connector is located on the PIB3G input panel and is used to control a limited set of projector functionality through contact closures. This table lists the control functions available through the SCCI:

Table 3.1 SCCI Connector Pinouts

PIN	SIGNAL NAME	DIRECTION	DESCRIPTION
1	+5V Standby	Out	Current limited 5VDC supply
2	Lamp ON	In	Projector at Power ON mode, lamp is ON
3	+5V Standby	Out	Current limited 5VDC supply
4	Lamp OFF	In	Projector at full power, lamp is OFF
5	+5V Standby	Out	Current limited 5VDC supply
6	Douser Closed	In	Close douser
7	Douser Open	In	Douser open
8	Health Output	Out	<p>Open Collector Low when one of the following interlocks is tripped or conditions present:</p> <ul style="list-style-type: none"> • Lamp Door • Lamp Blower • Extractor • Tamper • Ballast Communication <p>The show will not be able to play. Open Collector High when all interlocks relevant to CineLink and Lamp are not tripped. The show is able to play.</p>
9	Ground	Out	Ground

NOTE: All SCCI inputs require a pulse input of 50ms to several seconds to operate reliably. Inputs are 5V resistor current limited LED's inside of optocouplers.

A “Health Output” on this connector is also provided for locations that require a projector Health Output. The output is an open-collector circuit which only draws power when the projector is deemed to be “un-healthy”. The primary use of the Projector Health Output is to ensure that patrons are not left in a dark location due to projector fault. Therefore, any fault that results in the content playback stopping should cause this circuit to draw power and indicate an un-healthy state. The projector is always considered to be “healthy” in Standby Mode since there is no fear of projector fault causing an impact to patrons in this mode.

3.3 Connect Devices to the GPIO Port

The GPIO port is a 37-pin D-sub connector (female) located on the PIB3G input panel and provides 8 input and 7 output signals for connecting external devices to the projector. To configure the pins on the connector, tap **Menu > Administrator Setup > GPIO Setup**.

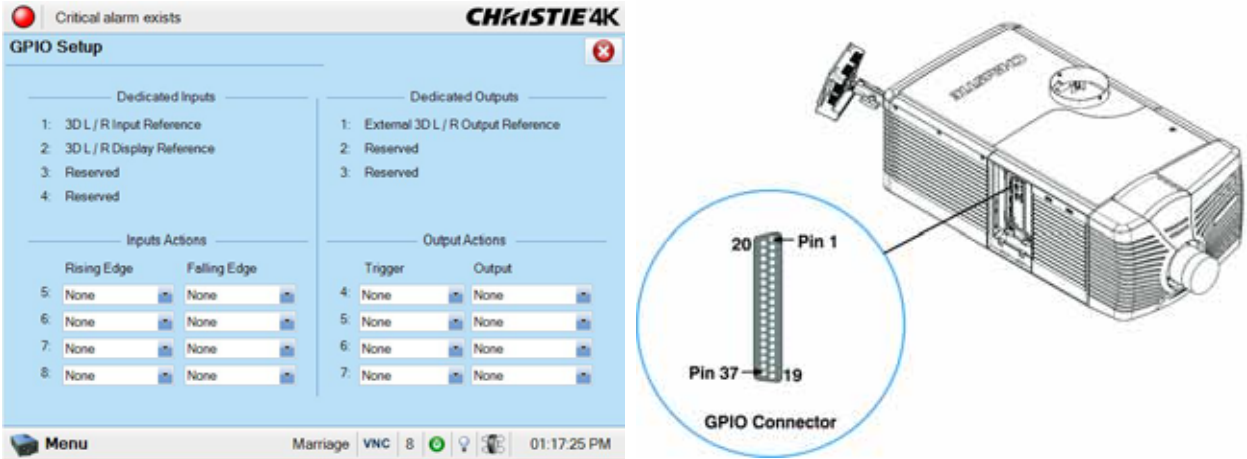

Figure 3-4 Admin: GPIO Setup Window and GPIO Port Location on Projector

As shown below, each available pairing of pins (+/-) is defined as either an *input* or *output*. Four inputs and three outputs have already been predefined. Configure a pin as an input if you want the projector to respond to an incoming signal, or as an output if you want an external device to respond to the projector.

Inputs	Positive	Negative	Description
GPIN #1	Pin 1	Pin 20	3-D L/R Input Reference
GPIN #2	Pin 2	Pin 21	3-D L/R Display Reference
GPIN #3	Pin 3	Pin 22	Reserved
GPIN #4	Pin 4	Pin 23	Reserved
GPIN #5	Pin 5	Pin 24	Input
GPIN #6	Pin 6	Pin 25	Input
GPIN #7	Pin 7	Pin 26	Input
GPIN #8	Pin 8	Pin 27	Input

Outputs	Positive	Negative	Description
GPOUT #1	Pin 9	Pin 28	External 3-D L/R Output Reference
GPOUT #2	Pin 10	Pin 29	Reserved
GPOUT #3	Pin 11	Pin 30	Reserved
GPOUT #4	Pin 12	Pin 31	Output
GPOUT #5	Pin 13	Pin 32	Output
GPOUT #6	Pin 14	Pin 33	Output
GPOUT #7	Pin 15	Pin 34	Output
PROJ_GOOD	Pin 16	Pin 35	Projector Good

If you are wiring your own GPIO cable for use with a server or 3D device such as an IR emitter or a polarizer, follow the circuit diagram.

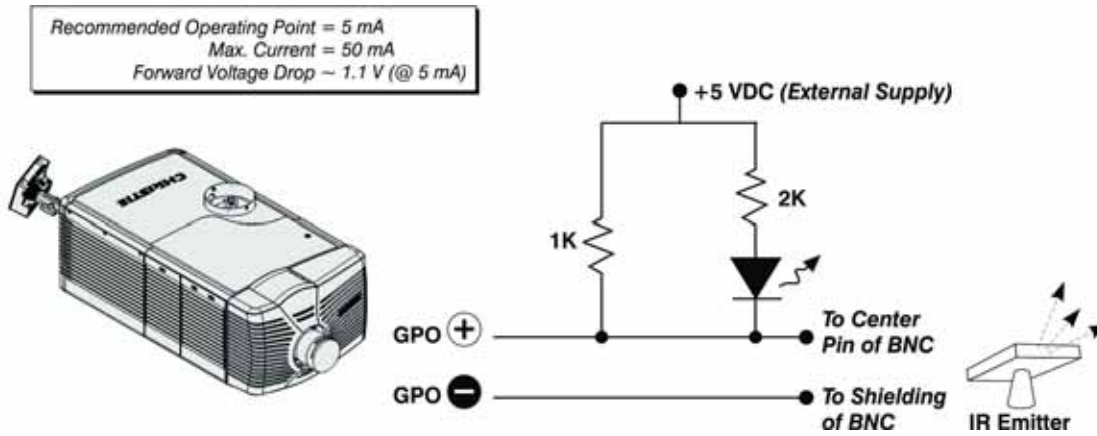

Figure 3-5 GPIO Circuit Diagram

3.4 Connect Devices to the 3D Connector

The 3D connector is a 15-pin D-sub connector (female) located on the PIB3G Board. The following table lists the control functions available through the 3D connector.

PIN	SIGNAL NAME	DIRECTION	DESCRIPTION
1	+12V	Out	Power to 3D device. Maximum 1A (total between both +12V pins).
2	GND	/	Ground
3	GND	/	Ground
4	RS232_RX	In	Data to projector from 3D device. 1200 Baud, 8 bits, no parity. Currently unsupported.
5	RS232_TX	Out	Data to projector from 3D device. 1200 Baud, 8 bits, no parity. Currently unsupported.
6	CONN_3D_MODE+	Out	SYNC from projector. To projector GPO collector. Compatible with current projector GPIO requirements and restrictions. (24VDC max, 50mA max) 3D ON = Hi logic level = O/P transistor ON 3D OFF = Low logic level = O/P transistor OFF
7	CONN_SYNC+	Out	SYNC from projector. To projector GPO collector. Compatible with current projector GPIO requirements and restrictions. (24VDC max, 50mA max)
8	3D_INPUT_REFERENCE+	In	3D L/R Input Reference (P) (Voltage Limit: 1.4VDC to 12VDC)
9	+12V	Out	Power to 3D system. Maximum 1A (Total between both +12V pins)
10	3D_INPUT_REFERENCE-	In	3D L/R Input Reference (N) (Voltage limit: 1.4VDC to 12VDC)
11	3D_DISPLAY_REFERENCE+	In	3D L/R Input Reference (P) (Voltage limit: 1.4VDC to 12VDC)
12	3D_DISPLAY_REFERENCE-	In	3D L/R Input Reference (P) (Voltage limit: 1.4VDC to 12VDC)
13	CONN_3D_MODE-	Out	3D mode state from projector. From projector GPO emitter. Compatible with current projector GPIO requirements and restrictions. (24VDC max, 50mA max)
14	CONN_SYNC-	Out	SYNC from projector. From projector GPO emitter. Compatible with current projector GPIO requirements and restrictions. (24DC max, 50mA max)
15	Not connected		

4 Adjust the Image

This section provides information and procedures for adjusting the projector image.

4.1 Maximize Light Output

To ensure optimal operation and peak screen brightness, use LampLOC™ to adjust the lamp position whenever you install a new lamp. When you complete the LampLOC adjustment, the lamp is centered and is the correct distance from the illumination system. Before running LampLOC, verify that:

- The anode yoke is in the correct position for the lamp type.
 - The lamp extension nut is installed when using a CDXL-30SD lamp. Remove the nut if you are not using a CDXL-30SD lamp.
 - The lamp is on and the douser is open.
1. On the Touch Pad Controller, tap the **Test Patterns** icon.
 2. Tap the **Full Screen White** test pattern.
 3. Tap **Menu > Advanced Setup > LampLOC™ Setup**.
 4. Tap **Do Auto**.

4.2 Calibrate Screen Brightness (fL)

1. On the Touch Pad Controller, tap **Menu > Administrator Setup > Foot Lamberts Calibration**.
2. Complete the **Foot Lamberts Calibration** wizard.

4.3 Basic Image Alignment

This procedure ensures that the image reflected from the digital micromirror device (DMD) is parallel and centered with the lens and screen. This procedure must be completed before you complete a boresight adjustment.

1. Verify the projector is properly positioned relative to the screen. See 2.3 Position the Projector.
2. Display a test pattern that you can use to analyze image focus and geometry. The framing test pattern works well for this.
3. Perform a preliminary focus and (if available) a zoom adjustment with the primary lens. Focus the center of the image first.
4. Hold a piece of paper at the lens surface and adjust the offsets until the image is centered within the lens perimeter.
5. With the framing test pattern on screen, re-check projector leveling so the top edge of the image is parallel to the top edge of the screen.

4.4 Adjust Offset

Project an image with the primary lens. Always adjust offset before boresight.

Select a framing test pattern and then adjust the horizontal and vertical offset to display a square image on the screen with minimal projector aiming error. (Figure 4-1)

NOTES: 1) For the best optical performance and minimize keystone error, use offset and not aiming to center the image in off axis installations. **2)** Avoid extreme tilts or offsets. Corner vignettes on a white test pattern indicate extreme offset that should be avoided using mechanical alignment.

4.5 Adjust Offset with an ILS

Project an image with the primary lens. Always adjust offset before boresight. Ensure the correct lens is selected in the Advanced Setup: Lens Adjust window before calibration to ensure you remain within the applicable boundary of the installed lens.

1. Tap **Menu > Advanced Setup > Lens Setup**.
2. Tap **Enable Automatic ILS**. Enabling Automatic ILS overwrites the pre-defined settings for the channel.
3. Tap the Test Patterns icon and select a framing test pattern.
4. Tap **Menu > Advanced Setup > ILS File Setup**.
5. Tap the directional arrows in the **Offset** area. For best optical performance, make sure to minimize keystone error by using offset more than aiming to center the image in off axis installations. Avoid extreme tilts or offsets. Corner vignettes on a white test pattern indicates extreme offset that should be avoided using mechanical alignment.

4.6 Adjust Left and Right Boresight

When performing these adjustments the goal is to balance the tilt of the lens mount to compensate for screen to projector tilt, but also to precisely maintain the original factory settings of the lens mount axial position.

1. Loosen the horizontal hold screw.
2. Extend the lens focus completely.

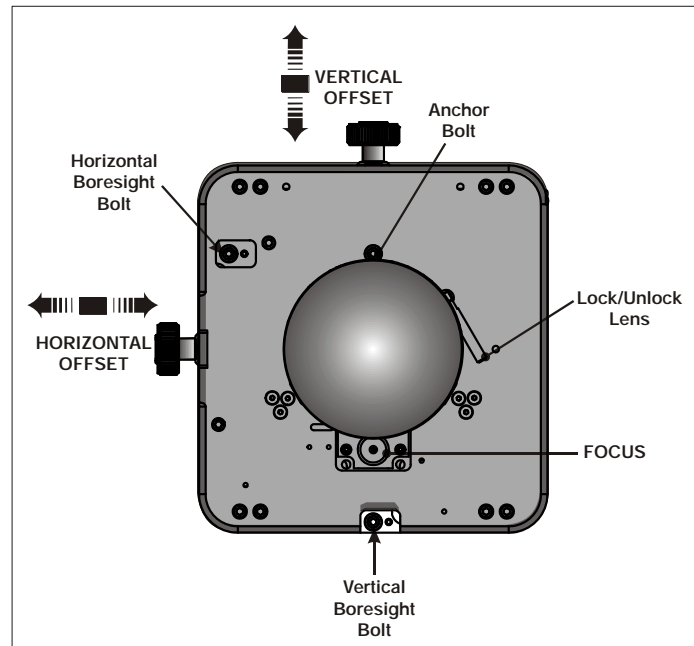

Figure 4-1 Standard Lens Mount

3. Adjust the **Focus** using the focus knob to retract the lens. (**Figure 4-2**) Watch the image at the left edge of the screen until it comes into focus. If the entire screen is in focus, proceed to step 7.

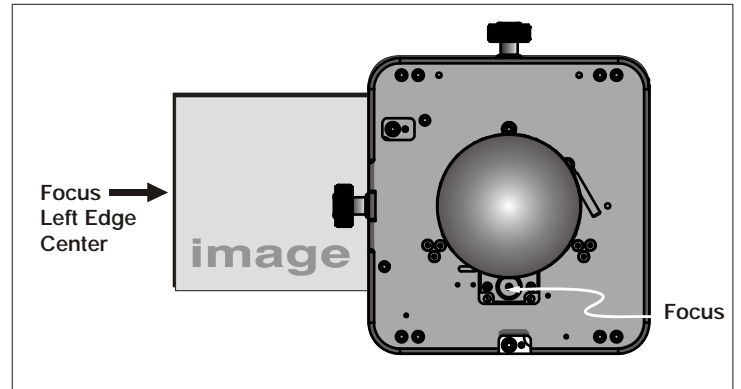

Figure 4-2 Adjust Focus

4. Continue retracting the lens.
 - a. If the right side of the image comes into focus before the lens is completely retracted, adjust the horizontal boresight bolt to balance the left and right edges.
 - b. If the right side of the image fails to come into focus, adjust the horizontal boresight bolt.
5. When both sides appear equally blurry, adjust the horizontal or vertical offset to re-center the image.

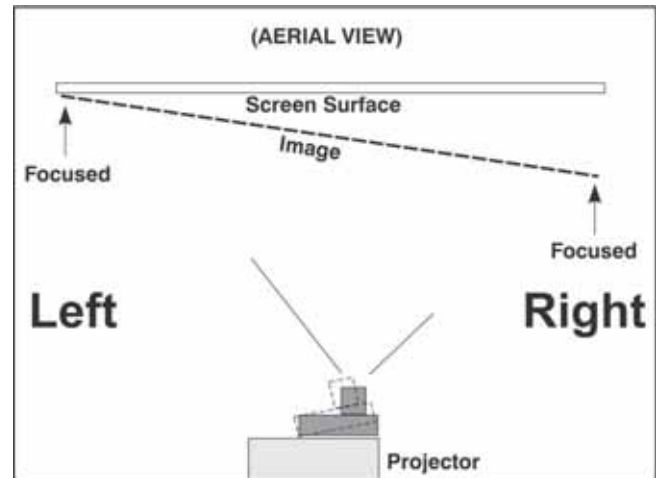

Figure 4-3 Aerial View Illustrating Misaligned Boresight

6. Repeat steps 1 - 5 until both sides of the image are focused.
7. Tighten the horizontal hold screw to maintain your adjustments.
8. Check the boresight again.

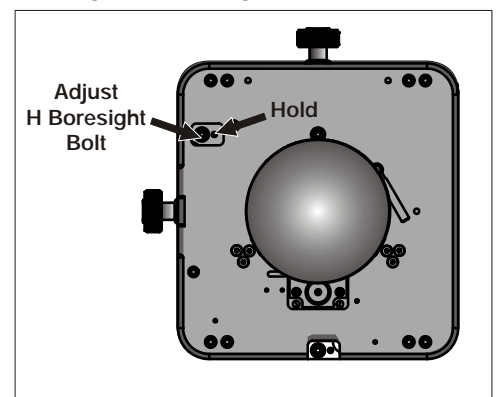

Figure 4-4 Adjust Horizontal Boresight Bolt

4.7 Adjust Top and Bottom Boresight

1. Focus the image at the top edge of the screen.
2. Loosen the vertical hold screw.
3. Extend the lens focus completely.
4. Adjust the **Focus** knob to retract the lens. Watch the image at the top edge of the screen until it comes into focus. If the entire screen is in focus, proceed to step 8.

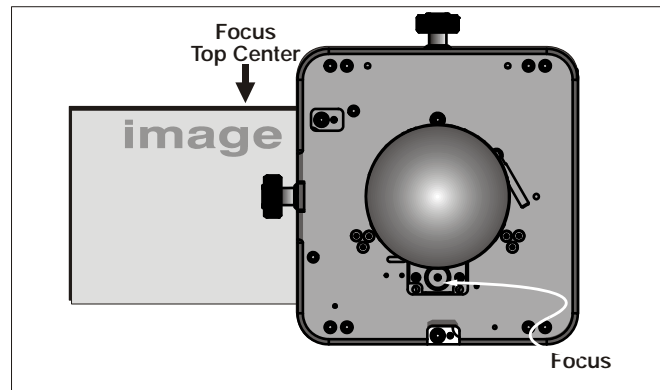

Figure 4-5 Focus Top Center of Screen

5. Continue retracting the lens.
 - a. If the bottom edge of the image comes into focus before the lens is completely retracted, adjust the vertical boresight bolt to direct or aim the lens mount UP towards the top of the screen to balance out the top/bottom edges.
 - b. If the top edge of the image is not in focus, adjust the vertical boresight bolt to direct or aim the lens mount toward the bottom of the screen.
6. When both sides appear equally blurry, adjust the horizontal and/or vertical offset to re-center the image on the screen.
7. Repeat Steps 2 - 5 until the top and bottom of the screen are both well-focused.
8. Re-focus the center of the image. The goal is for good focus at the center and on all sides.
9. Tighten the vertical hold screw to maintain your adjustments.
10. Check the boresight again.

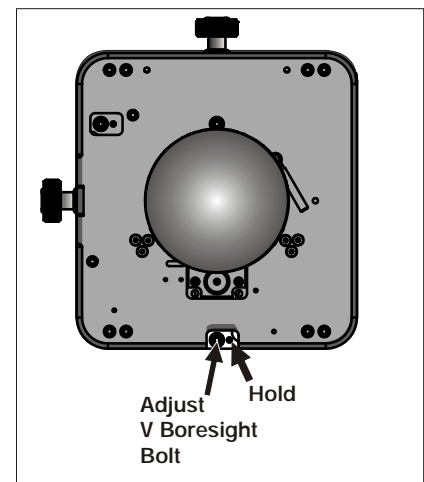

Figure 4-6 Adjust Vertical Bore-sight Bolt

4.8 Adjust Top and Bottom Boresight with an ILS

1. Loosen the **Vertical Locking Screw**.
2. Extend the lens focus completely.
3. Adjust the Focus to retract the lens using the counter-clockwise button on the ILS Adjust window. Watch the image at the top edge of the screen until it comes into focus. If the image appears well focused on the top edge but not on the bottom, we need to determine if the bottom edge focuses in front of or behind the screen. If the entire screen comes into focus, skip to step 8.
4. Continue retracting the lens.
 - a. If the bottom edge of the image comes into focus before the lens is completely retracted, then the image focuses in front of the screen. To correct this problem, adjust the **Vertical Boresight Bolt** to direct or aim the lens mount UP towards the top of the screen to balance out the top/bottom edges.
 - b. If the top edge of the image fails to come into focus then the image focuses behind the screen. To correct this problem, adjust the **Vertical Boresight Bolt** to direct or aim the lens mount DOWN towards the bottom of the screen.
5. When both sides appear equally blurry, tap **Menu > Advanced Setup > ILS File Setup** and tap the directional arrows in the **Offset** area to center the image on the screen.
6. Repeat Steps 2 - 5 until the top and bottom of the screen are both well-focused.
7. Although all sides of the image should now be in focus, the center of the image may be slightly blurry at this point. Re-focus the center of the image. The goal is for good focus at the center and on all sides.
8. Adjust the **Vertical Locking Screw** to lock the lens mount in place and check boresight again.

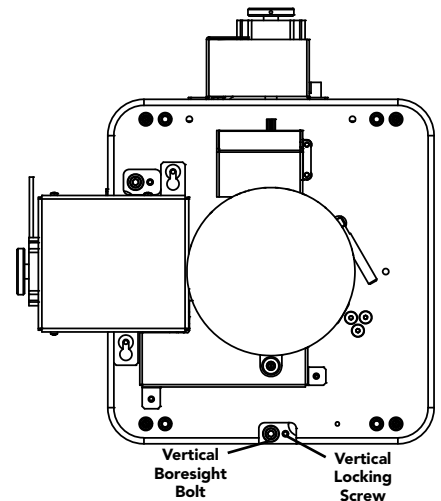

Figure 4-7 Vertical Boresight

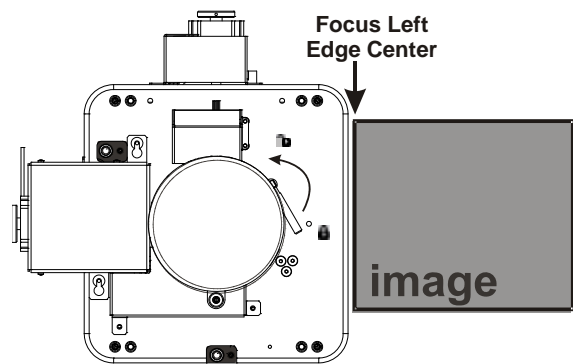

Figure 4-8 Adjust Vertical Boresight

4.9 Adjust DMD Convergence

⚠ DANGER UV EXPOSURE! Protective UV glasses must be worn when performing convergence adjustments.

A convergence problem occurs when one or more projected colors (red, green, blue) appears misaligned when examined with a convergence test pattern. Normally, the three colors should overlap precisely to form pure white lines throughout the image and one or more poorly converged individual colors may appear adjacent to some or all of the lines. Contact your Christie accredited service technician to correct DMD convergence issues.

4.10 Fold Mirror Adjustment

If a corner or edge of an image is missing, the fold mirror might be misaligned with the optical system. To correct this issue:

- Adjust the screw closest to the operator's side (right side, when facing screen) to raise or lower the image.
Adjust the screw on the left side to move the image left or right.

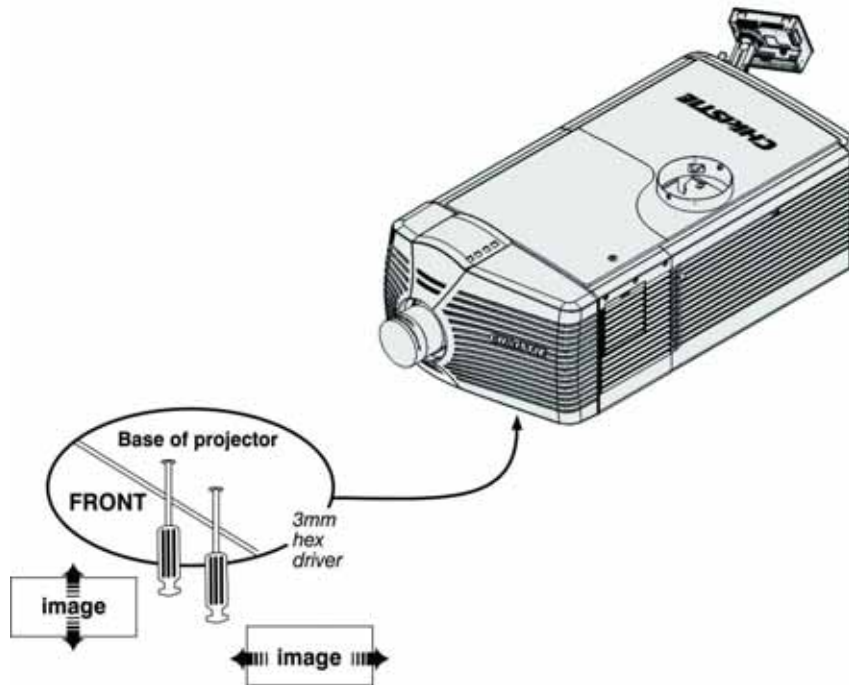

Figure 4-9 Fold Mirror Adjustment

4.11 Calibrate the System

Use the TPC to calibrate the image color performance and define electronic screen masking. This is required in your particular installation for the creation of Source, Screen, MCGD and TCGD files necessary for proper display of incoming material. You can also define the system/network configuration for communication links to the projector and transmit information to and from the D4K35 via an Ethernet or RS-232 connection.

4.12 Color Calibration

To ensure an accurate color display:

1. Measure the colors displayed on the screen from the center of the audience viewing location to determine the Measured Color Gamut Data (MCGD) value.
2. On the Touch Pad Controller tap **Menu > Advanced Setup > MCGD File Setup** and enter the color values in the x and y fields for the different colors.

Tap **Save**. The software automatically determines the Target Color Gamut Data (TCGD) value. The TCGD value determines what corrections are needed to display the correct colors.

4.13 Electronic Screen Masking



You can use the masking tool to correct image edge blanking. The masking tool produces results that are similar to filing the aperture plate in a film projector. After you create the Flat and Scope screen files you can use them in multiple channels.

5 Projector Operation



This section provides information and procedures for operating the projector.

5.1 Turn the Projector On

WARNING! Do not attempt to turn the projector on if the AC supply is not within the specified voltage range.

1. Turn the circuit breaker for the projector on.
2. On the Touch Panel Controller (TPC), tap and hold the green power  icon.
3. On the TPC, tap and hold the light bulb  icon to ignite the lamp.

5.2 Turn the Projector Off

1. On the Touch Panel Controller (TPC), tap and hold the light bulb  icon to turn the lamp off.
2. On the TPC, tap and hold the red power  icon. The projector enters a cool down mode and the fans and electronics stay on for 10 minutes. After this cool down period, the projector enters standby mode.
3. If you are servicing the projector, or removing the protective cover, disconnect AC and turn the breaker OFF.

5.3 Using the Touch Panel Controller (TPC)

The TPC is a touch-sensitive screen that you use to control the projector. You can use the TPC to turn the projector and lamp on or off, select channels, and view status information. The TPC is mounted on the rear of the projector. You can tilt and turn the TPC to improve the viewing angle. There are two USB ports under a cover on the rear of the TPC that you can use to download log files and install software upgrades. You can disconnect the TPC from the projector and an optional cable allows you to control the projector from a maximum distance of 100 feet.

If the TPC fails or is disconnected, press the emergency start button that is recessed on the faceplate. This starts the projector, turns the lamp on, and opens the douser.

6 Maintenance

This section provides information and procedures for performing projector maintenance. You should read through this section in its entirety before performing maintenance activities. When you perform projector maintenance, obey all warnings and precautions.

 **DANGER**

ELECTRICAL SHOCK HAZARD! Always turn off, disconnect, and disengage all power sources to the projector before servicing. Failure to comply results in death or serious injury.

 **CAUTION**

Only Christie accredited service technicians are permitted to open any enclosure on the projector and only if the AC power has been fully disconnected. Failure to comply could result in minor or moderate injury.

6.1 Ventilation

Vents and louvers in the projector covers provide ventilation, both for intake and exhaust. Never block or cover these openings. Do not install the projector near a radiator, heat register, or within an enclosure. To ensure adequate airflow around the projector, keep a minimum clearance of 50cm (19.69”) on the left, right, and rear sides of the projector.

6.2 Filling the Coolant Reservoir

⚠ DANGER HAZARDOUS SUBSTANCE! The coolant used in the projector contains ethylene glycol. Use caution when handling. **DO NOT ingest.**

⚠ WARNING Only use coolant recommended by Christie in your projector. Using unapproved coolant can result in projector damage and voids the projector warranty

The liquid cooler system sends and receives coolant from the digital micromirror device (DMD) heat sinks. Check the coolant level every 6 months, by removing the top projector lid. The coolant level should always be above the minimum level indicator. If the liquid cooling system fails, an over-temperature alarm window appears in the Touch Pad Controller (TPC). The lamp turns off if the projector enters an over-temperature state for longer than one minute.

Top up the coolant with the Christie approved coolant JEFFCOOL E105. Use the refill bottle (with the nozzle) provided in the Liquid Coolant Fill Service Kit (P/N: 003-001837-xx). When refilling, use caution not to spill or let any of the coolant drip on or near the electronics. After filling the reservoir, check the coolant hoses for kinks which may restrict fluid flow.

If coolant drips on electronics or other components, blot the affected area using a dust-free optical grade tissue. It is recommended you blot a few times, discard the tissue and use a new tissue to blot the area again. Keep repeating this cycle until the coolant is removed. Then lightly moisten a new tissue with de-ionized water and blot the area again. Use a dry tissue to dry the area.

6.3 Inspect the Lamp

⚠ DANGER Always disconnect the projector from AC power and wear authorized protective safety gear.

- Check the contact surfaces of the anode (positive) and the cathode (negative) connections for cleanliness.
- Clean electrical contact surfaces regularly to prevent contact resistance from scorching connectors. Use an approved contact cleaner.

Verify that all electrical and lamp connections are secure.

6.4 Inspect and Clean Optics

Unnecessary cleaning of optics can increase the risk of degrading delicate coatings and surfaces. If you are not a qualified service technician, you can only inspect and clean the lens and lamp reflector. Do not perform maintenance on other optical components. Check these components periodically in a clean, dust-free environment using a high-intensity light source or flashlight. Clean them only when dust, dirt, oil, fingerprints or other marks are obvious. Never touch an optical surface with your bare hands. Always wear latex lab gloves.

- These are the recommend tools for removing dust or grease:
- Soft camel-hair brush
- Dust-free blower - filtered dry nitrogen blown through an anti-static nozzle.
- Dust-free lens tissue, such as Melles Griot Kodak tissues (18LAB020), Opto-Wipes (18LAB022), Kim Wipes or equivalent.
- For the lens only - lens cleaning solution such as Melles Griot Optics Cleaning Fluid 18LAB011 or equivalent
- For the reflector only - Methanol.
- Cotton swabs with wooden stems.
- Lens cleaning cloth or microfiber such as Melles Griot 18LAB024 or equivalent.

6.4.1 Clean the Lens

A small amount of dust or dirt on the lens has minimal effect on image quality-to avoid the risk of scratching the lens, clean the lens only if absolutely required.

Remove Dust

1. Brush most of the dust off with a camelhair brush or use a dust-free blower.
2. Fold a microfiber cloth and wipe the remaining dust particles off the lens with the smooth portion of the cloth that has no folds or creases. Do not apply pressure with your fingers. Instead, use the tension in the folded cloth to remove the dust.
3. If significant dust remains on the lens surface, dampen a clean microfiber cloth with lens cleaning solution and wipe gently until clean.

Remove Fingerprints, Smudges, or Oil

1. Brush most of the dust off with a camelhair brush or use a dust-free blower.
2. Wrap a lens tissue around a swab and soak it in lens cleaning solution. The tissue should be damp but not dripping.

3. Gently wipe the surface using a figure eight motion. Repeat until the blemish is removed.
lean the lens only if absolutely required.

6.4.2 Cleaning the Lamp Reflector

Inspect the mirror surface (reflector) for cleanliness when you remove the lamp for replacement. Wear protective clothing while inspecting or cleaning. Color variations on the reflector are normal.

Remove Dust

1. Brush most of the dust off with a camelhair brush or use a dust-free blower.
2. If some dust remains, leave it. Some dust is inevitable. Avoid unnecessary cleaning.

Remove Fingerprints, Smudges, or Oil

1. Brush most of the dust off with a camelhair brush or use a dust-free blower.

Fold a microfiber cloth and wipe the remaining dust particles off the lens with the smooth portion of the cloth that has no folds or creases. Do not apply pressure with your fingers. Instead, use the tension in the folded cloth to remove the dust.

6.5 Inspect and Clean the Lamp Blower

NOTICE! DO NOT bend the impeller blades or loosen the balancing weights.

A clogged lamp blower impeller or motor can reduce air flow leading to overheating and failure of the lamp.

1. Vacuum loose dirt from the lamp blower impeller.
2. If necessary, use a brush with hot water.
3. Fold a clean microfiber cloth and dampen with methanol and wipe evenly with the smooth portion of the cloth that has no folds or creases. **Do not apply pressure with your fingers.** Use the solution in the cloth to collect the dirt.

6.6 Clean the Igniter

Clean the high voltage terminal and insulator to remove accumulated dust or dirt.

6.7 Inspect and Clean the Airflow Interlocks

The D4K35 uses two airflow interlocks; a lamp blower vane switch and an extractor vane switch.

The lamp blower vane switch is located within the lamp cooling compartment. The extractor vane switch is located just inside the top duct on the projector lid. Check and clean the switches to remove accumulated dust or dirt that could impede movement if necessary. Within the exhaust duct connected at the top of the projector, adequate airflow must be maintained and routed outside of the building. Inspect regularly and confirm that 1) there are no obstructions or “kinks” within the ducting, 2) all air intake areas are unobstructed, and 3) exhaust airflow is at least 450 CFM* (measured at the rigid end of the duct when not connected to the projector). Refer to [6.1 Ventilation](#).

* 600 CFM is required in projection rooms with ambient temperature above 25°C or elevation (above sea level) greater than 3000 feet.

6.8 Inspect the Laminar Airflow Device (LAD)

The LAD filter is attached to the light engine assembly handle in the light engine compartment. Inspect the LAD filter every six months. If the LAD filter is dark grey, contact Christie or your dealer for replacement.

6.9 Replace the Lamp

⚠ DANGER 1) Lamp replacement must be performed by a qualified service technician only. 2) **EXPLOSION HAZARD.** Wear authorized protective clothing whenever the lamp door is open and when handling the lamp. Never twist or bend the quartz lamp body. Use the correct wattage lamp supplied by Christie. 3) Ensure those within the vicinity of the projector are also wearing protective safety clothing. 4) Never attempt to remove the lamp when it is hot. The lamp is under a great deal of pressure when hot and may explode, causing personal injury or death and/or property damage. Allow the lamp to cool completely before replacing it.

1. Tap and hold the red power button  on the TPC **Main** panel to turn the lamp and projector off.
2. Allow the lamp to cool for a minimum of 10 minutes.
3. Unplug the projector.
4. Put on your protective clothing and face shield.
5. Unlock and open the lamp door. Release the tethered latch mechanism to remove the door entirely.
6. Remove the old lamp and inspect the reflector:
 - a. Remove the front lamp duct to reveal the cathode end (-) of the lamp.
 - b. Loosen the set screw securing the anode connector.
 - c. Loosen the set screw securing the cathode connector.
 - d. Slip the positive anode connector off the front of the lamp.
 - e. Hold the lamp from the cathode end and carefully unscrew the lamp from the cathode connector ensuring not to make contact with the reflector.
 - f. With your free hand guide the cathode end out of the reflector, on an angle.
 - g. Before placing the old lamp into the protective case ensure the cathode nut is reinstalled. Place the lamp, within the case, on the floor where it cannot fall or be bumped. **WARNING! Handle box with extreme caution - the lamp is hazardous even when packaged. Dispose of lamp box according to local area safety regulations.**
 - h. With the lamp removed, visually inspect the reflector for dust. If necessary, clean the reflector.

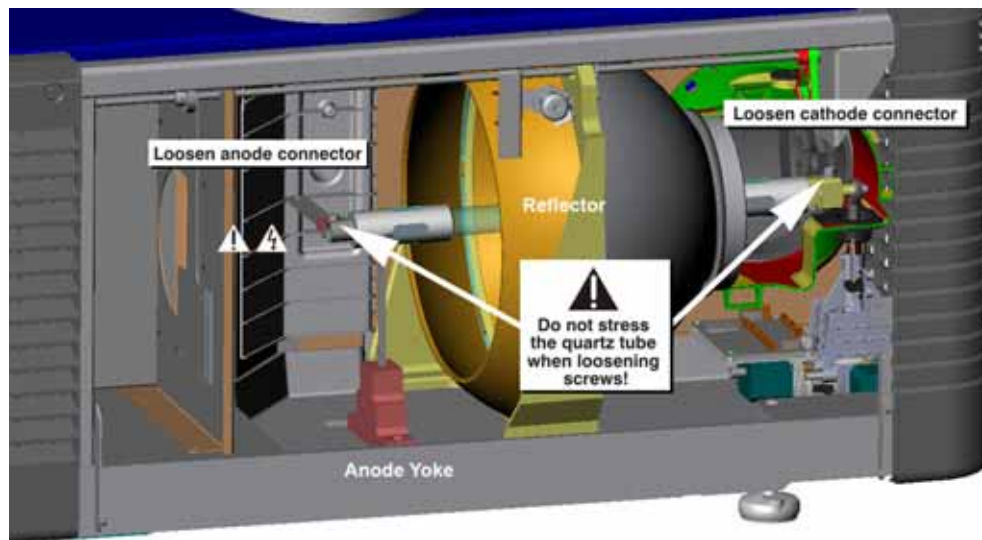

Figure 6-1 Removing the Lamp

7. Remove the new lamp from the protective case. **NOTE:** Before removing the lamp from the case loosen the cathode screw and remove the cathode nut from the lamp.
8. Install the new lamp:

⚠ CAUTION Handle the lamp by the cathode/anode end shafts only, never the glass. **DO NOT over-tighten. DO NOT stress the glass in any way. Check leads. Ensure the anode (+) lead between the lamp and igniter is well away from any projector metal, such as the reflector or firewall.**

- a. Hold the anode end of the lamp in your left hand and angle it up through the hole in the back of the reflector assembly. Insert your right index and middle finger through the back front of the reflector and guide the lamp onto the cathode clamp. **Be careful** not to hit the lamp against the reflector.
- b. Insert the threaded cathode (-) end of the lamp into the negative lamp connector nut located in the rear of the lamp compartment. (**Figure 6-2**) Using both hands, hand-tighten this end into the threaded nut.
- c. **Caution! 1)** Handle the lamp by the cathode/anode end shafts only, never the glass. **DO NOT over-tighten. DO NOT stress the glass in any way. 2)** Check leads. Make sure the anode (+) lead between the lamp and igniter is well away from any projector metal such as the reflector or firewall.
- d. Rest the anode (+) end of the lamp on the anode yoke and slip the positive lamp connector over the bulb end. (**Figure 6-2**) Using the 5mm Allen key, squeeze together with the anode clamp making sure not to place any torque on the lamp quartz tube. **Important!** For CDXL-30SD lamps, make sure the “flat” part of the anode end of the lamp (if applicable) is facing in the 10 or 2 o’clock position once the lamp finger is installed in the 14mm threads and the clamp screw is tightened. For all other lamp types, keep the “flat” part of the anode end of the lamp facing up. **WARNING! Explosion hazard - Do not apply torque to the anode end of the lamp.**
- e. Tighten the anode and cathode set screws.

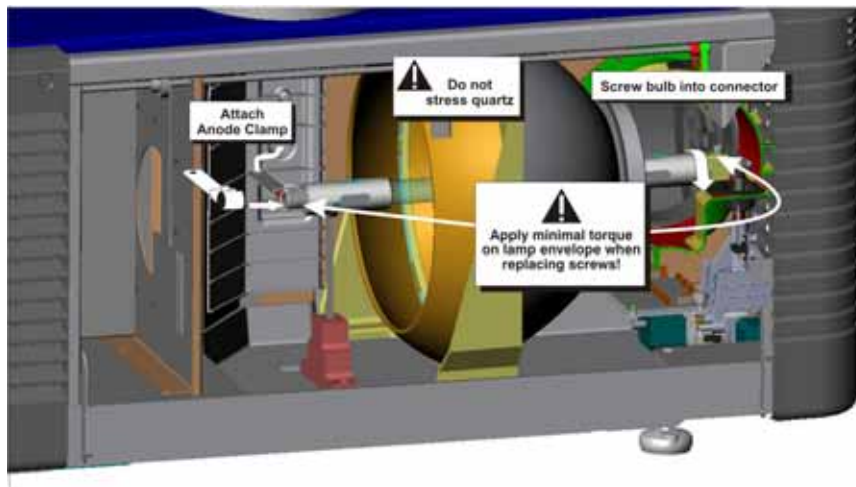



Figure 6-2 Installing the Lamp

9. Re-install the front lamp duct. As you install the front lamp duct, lift the small light shield on the rear lamp duct cover so that it does not get jammed between the two pieces when they come together. (**Figure 6-3**) To ensure a good fit between the two pieces, squeeze the top and bottom cover snaps to ensure they are locked in place. The light shield should move freely to the touch.
10. Close the internal lamp door and manually turn the 2 thumbscrews to lock it in place.
11. Turn the circuit breaker for the projector on.
12. On the Touch Panel Controller (TPC), tap and hold the green power  icon.
13. Record the new lamp information:
 - a. Tap **Menu > Advanced Setup > Lamp History**.
 - b. Tap **Add Lamp**.
 - c. Complete the fields in the **Add Lamp** dialog.
 - d. Tap **Save**.
14. On the TPC, tap and hold the light bulb  icon to ignite the lamp.
15. Run a LampLOC™ on the new lamp:
 - a. Tap **Menu > Advanced Setup > LampLOC™ Setup**.
 - b. Tap **Do Auto**.

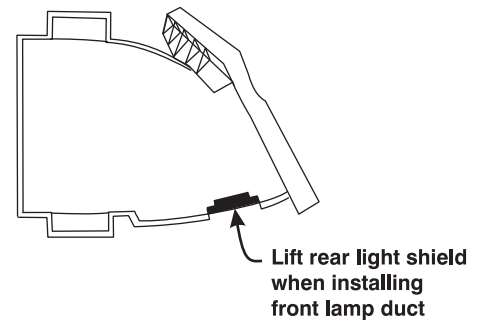



Figure 6-3 Light Shield on Front Lamp Duct

6.10 Rotating the Lamp

⚠ DANGER 1) Lamp rotation must be performed by a qualified service technician only. 2) **EXPLOSION HAZARD!** Wear authorized protective clothing whenever the lamp door is open and when handling the lamp. Never twist or bend the quartz lamp body. Use the correct wattage lamp supplied by Christie. 3) Ensure those within the vicinity of the projector are also wearing protective safety clothing. 4) Never attempt to remove the lamp when it is hot. The lamp is under pressure when hot and may explode, causing personal injury, death, or property damage. Allow the lamp to cool completely.

When the operational life of the lamp reaches halfway, it is recommended that you rotate it 180° to ensure an even burn of the lamp, improve lamp performance, and extend the life of the lamp. An alarm window appears on the TPC after you complete the lamp rotation.

1. Tap and hold the red power button  on the TPC **Main** panel to turn the lamp and projector off.
2. Allow the lamp to cool for a minimum of 10 minutes.
3. Unplug the projector.
4. Put on your protective clothing and face shield.
5. Unlock and open the lamp door. Release the tethered latch mechanism to remove the door entirely.
6. Remove the cathode cable and rotate the lamp 180°.
7. Replace the cathode cable.
8. Replace and lock the lamp door.
9. Remove your protective clothing and face shield.
10. Tap and hold the green power button to turn the projector on.
11. Tap **Menu > Advanced Setup > Lamp History**.
12. Tap **Acknowledge Lamp Rotation**.

6.11 Replace the Light Engine Air Filter

⚠ CAUTION Use only high efficiency Christie approved filters. Never operate the projector without the filter installed. Always discard used air filters.

You should check the condition of the light engine air filter monthly. Replace the light engine air filter when you replace the lamp module or sooner if you are operating the projector in a dusty or dirty environment. The filter is located on the right side of the projector behind the air filter cover.

1. Release two tabs on the air filter cover and remove.
2. Slide the air filter out and discard. Insert the new air filter with the airflow indicator facing toward the projector. **NOTE:** *Never reuse an old air filter. The air filters in this product cannot be cleaned thoroughly enough for reuse and can lead to the contamination of optical components.*
3. Install the air filter cover by inserting the two bottom tabs into place and then snapping the door closed.

6.12 Replace the Liquid Cooling Air Filter

The radiator air filter is located on left/front side of the projector behind a small air filter cover.

1. Release a single tab on the air filter cover and remove.
2. Slide the air filter out and discard. Insert the new air filter with the air flow indicator facing toward the projector. **NOTE:** *Never reuse an old air filter. The air filters in this product cannot be cleaned thoroughly enough for reuse and can lead to the contamination of optical components.*

6.13 Replace the Lens

1. Tap and hold the red power button  on the TPC **Main** panel to turn the lamp and projector off.
2. Allow the lamp to cool for a minimum of 10 minutes.
3. Unplug the projector
4. Turn the lens clamp to the OPEN/UP position.
5. Release the lens locking lever (UP position).
6. Pull out the lens and replace it with a different high-brightness lens. **NOTE:** *Always install the lens with “UP” label in the top position. This will assist in achieving consistent boresight alignment each time the lens is replaced. See [Section 2.11 Install the Primary Lens](#).*
7. Secure the lens with the lens locking lever (DOWN position).
8. Calibrate the lens.

7 Troubleshooting

This section provides information and procedures for resolving common projector issues. If you cannot resolve a projector issue, contact a Christie accredited service technician.

7.1 Projector Does Not Power ON

- Check the wall circuit breaker to see if it is ON. If there is a problem with the wall circuit breaker, have a certified electrician investigate any electrical problem.
- Check the status of the LEDs on the rear corners of the projector. (Figure 7-1). If there is no activity, see #3.
- Verify power by looking through the rear, right side grill. One LED should be present in the upper right. This indicates the LVPS has power. Another LED should be seen in the lower left indicating Main input. (Figure 7-2)
- On the TPC, verify in the **Operational Status** region of the **Main** panel that there is no failure with PIB3G communication (PIB Status).

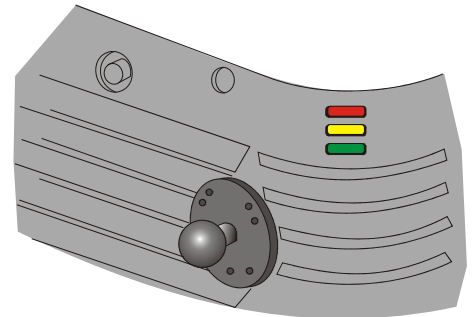

Figure 7-1 Projector Status LEDs

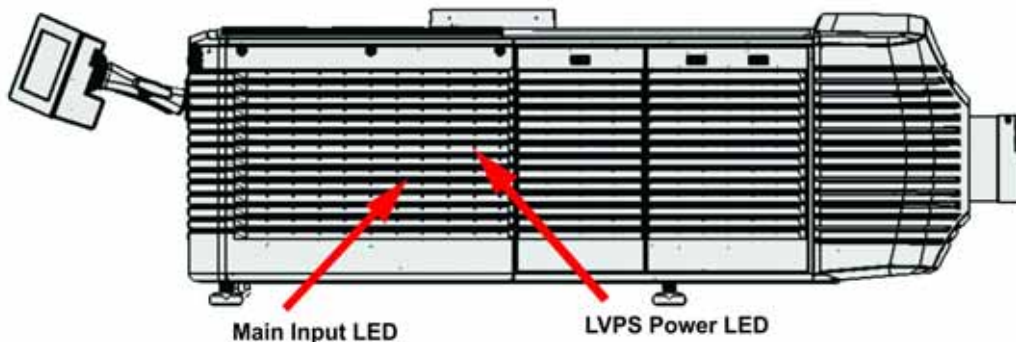

Figure 7-2 View Power Status LEDs

7.2 Lamp Does Not Ignite

- Tap **Menu > Advanced Setup > Lamp History** and verify the number of hours the lamp has operated. Replace a lamp nearing the end of its operational life
- Tap **Menu > Status** and then **Interlocks** in the left pane. Check and correct all interlock failures.
- Tap **Menu > Status** and then **All Alarms** in the left pane. If a ballast communication error has occurred, restart the projector and turn the lamp on.
- Tap **Menu > Status** and then **Temperatures** in the left pane. Verify if the DMD temperatures are too high. If the temperatures are too high, cool the projector. Ensure the projector is properly ventilated, the air filters are not blocked, and the liquid cooling reservoir has coolant.

- Listen for a clicking noise that indicates the ballast is attempting to strike the lamp. If you do not hear a clicking noise, there might be a problem with the ballast. Contact a Christie accredited service technician to resolve the issue.
- If you hear a brief clicking noise, but the lamp does not ignite, replace the lamp.
- Check the transformer Voltage switch on the transformer.

7.3 Lamp Suddenly Turns OFF

- Tap **Menu > Advanced Setup > Lamp Power/LiteLOC Setup**. Increase the lamp power.
- Tap **Menu > Status** and then **Interlocks** in the left pane. Review and correct all interlock failures.
- If EVB errors occur, check the door interlock.
- Tap **Menu > Status** and then **Temperatures** in the left pane. Verify if the DMD temperatures are too high. If the temperatures are too high, cool the projector. Ensure the projector is properly ventilated, the air filters are not blocked, and the liquid cooling reservoir has coolant.

7.4 Flicker, Shadows Or Dimness

- Ensure the douser is open.
- Run a LampLOC™ adjustment.
- Verify that a LampLOC™ adjustment is not in progress.
- Tap **Menu > Advanced Setup > LampPower/LiteLOC™ Setup**. Monitor the Power % field to determine if the power is consistent or varying. Increase the lamp power. Lamps which are near end of service may not operate reliably at a lower power setting.
- Fold mirror misalignment. Contact your Christie accredited service technician to resolve the issue.
- Integrator rod misalignment. Contact your Christie accredited service technician to resolve the issue.

7.5 LampLOC™ Not Working

- If the **Do Auto** option is not working, tap **Menu > Advanced Setup > LampLOC™ Setup** and adjust the lamp position manually. Observe screen brightness by adjusting the XYZ values or use a light meter to check for changes in brightness.
- Check that the anode yoke (lamp yoke) is in the correct position. (Figure 7-3)
- Check that the flat part of the anode end of the lamp (if applicable) faces up in the anode yoke.

7.6 LiteLOC™ Not Working

- Tap **Menu > Advanced Setup > LampPower/LiteLOC™ Setup**. Tap **Enable LiteLOC™**.
- If the lamp power is at the maximum setting to maintain a LiteLOC™ setting, LiteLOC™ is automatically disabled. Reduce the LiteLOC™ setting, or install a new lamp.

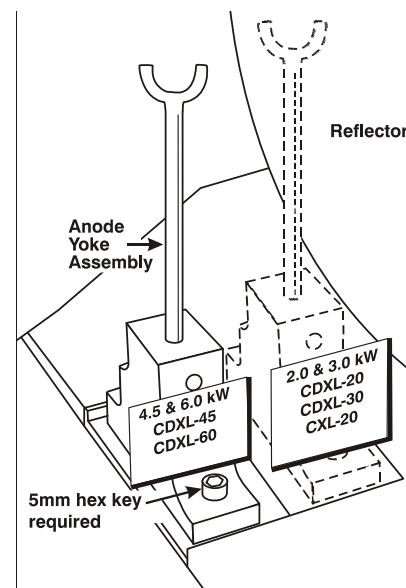

Figure 7-3 Lamp Yoke Position

7.7 Touch Panel Controller (TPC)

- If the TPC does not appear, restart the projector.
- If the TPC display is blank, ensure the TPC is on by opening the flap at the back of the TPC and verify the grey button in the bottom left corner is ON.
- If the button taps on are misinterpreted, the TPC screen may need recalibrating. Tap **Menu > Administrator Setup > Preferences**. Tap **Calibrate Screen** and follow the instructions on the screen.

7.8 Trouble Establishing Communication with Projector

Verify all input devices have the same subnet mask and unique IP addresses.

7.9 Blank Screen, No Display of Image

- Ensure the lens cap is not on either end of the lens.
- Ensure the lamp is ON.
- Confirm all power connections are OK.
- Ensure the douser is OPEN by verifying the state of the douser on Main panel as well as the state of the douser switch at the back of the projector in the top, left corner.
- Ensure any test pattern other than the full black test pattern displays properly.
- Verify the correct display file is selected?
- For all connections, verify the correct port is used

7.10 Inaccurate Display Colors

- Adjust the color, tint, color space, and color temperature settings of your input source. Tap **Menu > Channel Setup**. Tap **Config 1** in the left pane and verify the correct value is selected in the **PCF** list. Tap **Config 2** in the left pane and verify the correct value is selected in the **Color Space** field..

7.11 Display is Not Rectangular

- Verify the projector is level and the lens surface and screen are parallel to one another.
- Adjust the vertical offset of the lens mount with the vertical offset knob or ILS.
- Check that the anamorphic lens is straight. Rotate to orient the aperture correctly.
- Tap **Menu > Advanced Setup > Screen File Setup** and verify the settings for the screen file are correct.

7.12 Display is Noisy

- Adjust the input source pixel tracking, phase, and filter.
- Verify the video input is terminated (75 ohms). If the device is the last device in a linked series, verify the video input is terminated at the last input source.
- Verify the cables connecting the input device to the projector meet the minimum requirements.
- Add signal amplification or conditioning if the distance between the input device and the projector exceeds 25 feet.

7.13 Display has Suddenly Frozen

Turn off the projector and unplug the power cord from the power source. Plug the projector power cord into a power source and turn the projector on.

7.14 Data is Cropped from Edges

Reduce the image size to fill the display area, and then stretch the image vertically to fill the screen. Add an anamorphic lens to regain image width.

7.15 The Projector is ON, but There is No Image

- Ensure AC power is connected.
- Make sure the lens cover is removed from the lens.
- Make sure the douser is open.
- Tap  on the main TPC screen. If the lamp does not strike, see [Section 7.2 Lamp Does Not Ignite](#).
- Tap **Menu > Channel Setup**. Verify the correct channel is selected and the settings are correct.
- Ensure an active source is connected properly. Check the cable connections and make sure the alternative source is selected.
- Verify you can select test patterns. If you can, check your source connections again.

7.16 The Display is Jittery or Unstable

- Verify that the input device is connected properly. If the input device is not connected properly, the projector repeatedly attempts to display an image.
- The horizontal or vertical scan frequency of the input signal may be out of range for the projector.
- The sync signal may be inadequate. Correct the source problem.

7.17 Portions of the Display are Cut OFF or Warped to the Opposite Edge

If you have resized the image, adjust the resizing settings until the entire image is visible and centered.

7.18 The Display is Faint

- Verify the input source is terminated only once.
- If the input is not a video source, use a different sync tip clamp location.

7.18.1 Display Appears Compressed (Vertically Stretched)

- Adjust the frequency of the pixel sampling clock for the input source.
- Verify the size and position settings are correct for the input source.
- Use an anamorphic lens for HDTV and anamorphic DVD input sources that have been re-sized and vertically stretched.

7.19 Inconsistent Picture Quality

- Verify the quality of the signal from the input source.
- Verify the H and V frequencies of the input source are correct.

Corporate offices

USA – Cypress
ph: 714-236-8610
Canada – Kitchener
ph: 519-744-8005

Worldwide offices

United Kingdom
ph: +44 118 977 8000
France
ph: +33 (0) 1 41 21 00 36
Germany
ph: +49 2161 664540

Eastern Europe
ph: +36 (0) 1 47 48 100
Middle East
ph: +971 (0) 4 299 7575
Spain
ph: + 34 91 633 9990

Singapore
ph: +65 6877-8737
Beijing
ph: +86 10 6561 0240
Shanghai
ph: +86 21 6278 7708

Japan
ph: 81-3-3599-7481
South Korea
ph: +82 2 702 1601