

The top half of the page features a complex, abstract background of overlapping, semi-transparent blue triangles and polygons, creating a faceted, crystalline effect. The colors range from light sky blue to deep navy blue. A white diagonal line separates this patterned area from the plain white background below.

User Manual

020-001835-05

CP2306-RGBe, CP2308-RGBe, CP2310-RGBe

CHRISTIE

NOTICES

COPYRIGHT AND TRADEMARKS

Copyright © 2023 Christie Digital Systems USA, Inc. All rights reserved.

All brand names and product names are trademarks, registered trademarks or trade names of their respective holders.

GENERAL

Every effort has been made to ensure accuracy, however in some cases changes in the products or availability could occur which may not be reflected in this document. Christie reserves the right to make changes to specifications at any time without notice. Performance specifications are typical, but may vary depending on conditions beyond Christie's control such as maintenance of the product in proper working conditions. Performance specifications are based on information available at the time of printing. Christie makes no warranty of any kind with regard to this material, including, but not limited to, implied warranties of fitness for a particular purpose. Christie will not be liable for errors contained herein or for incidental or consequential damages in connection with the performance or use of this material. Canadian manufacturing facility is ISO 9001 and 14001 certified.

For the most current technical documentation and office contact information, visit www.christiedigital.com.

WARRANTY

Products are warranted under Christie's standard limited warranty, the details of which are available at www.christiedigital.com/help-center/warranties/ or by contacting your Christie dealer or Christie.

PREVENTATIVE MAINTENANCE

Preventative maintenance is an important part of the continued and proper operation of your product. Failure to perform maintenance as required, and in accordance with the maintenance schedule specified by Christie, will void the warranty.

REGULATORY (if applicable)

The product has been tested and found to comply with the limits for a Class A digital device, pursuant to Part 15 of the FCC Rules. These limits are designed to provide reasonable protection against harmful interference when the product is operated in a commercial environment. The product generates, uses, and can radiate radio frequency energy and, if not installed and used in accordance with the instruction manual, may cause harmful interference to radio communications. Operation of the product in a residential area is likely to cause harmful interference in which case the user will be required to correct the interference at the user's own expense. Changes or modifications not expressly approved by the party responsible for compliance could void the user's authority to operate the equipment.

CAN ICES-3 (A) / NMB-3 (A)

이 기기는 업무용(A급)으로 전자파적합등록을 한 기기이오니 판매자 또는 사용자는 이점을 주의하시기 바라며, 가정 외의 지역에서 사용하는 것을 목적으로 합니다.

ENVIRONMENTAL



The product is designed and manufactured with high-quality materials and components that can be recycled and reused. This symbol  means that electrical and electronic equipment, at their end-of-life, should be disposed of separately from regular waste. Please dispose of the product appropriately and according to local regulations. In the European Union, there are separate collection systems for used electrical and electronic products.

If printing this document, consider printing only the pages you need and select the double-sided option.

Please help us to conserve the environment we live in!

NOTATION

Learn the hazard and information symbols used in the product documentation.



Danger! If not avoided, the following could result in death or serious injury.



Warning! If not avoided, the following could result in death or serious injury.



Caution! If not avoided, the following could result in minor or moderate injury.



Notice. If not avoided, the following could result in property damage.

Content

- Safety precautions 11**
 - General precautions 11
 - AC/power precautions..... 11
 - Laser safety precautions 12
 - Light intensity hazard distance..... 12
 - Product labels..... 14
 - General hazards 14
 - Mandatory action..... 15
 - Electrical labels..... 15
 - Additional hazard labels..... 16

- Introduction..... 17**
 - Product documentation 17
 - Related documentation..... 17
 - Projector overview 17
 - Contact your dealer 18
 - Key features..... 18
 - Understanding the Christie touch panel interface..... 18
 - Environment..... 19
 - Technical support..... 20

- Operating the projector 21**
 - Turning the projector on or off..... 21
 - Logging on to the projector 21
 - Logging out of the projector 21
 - Turning the touch panel on or off 21
 - Calibrating the touch panel display..... 21
 - Turning the light source on or off 22
 - Opening or closing the douser..... 22
 - Selecting a channel 22
 - Adding a network time protocol server..... 22
 - Deleting a network time protocol server..... 23
 - Changing the time zone 23
 - Changing the time format 23

Automatically adjusting the time for daylight saving time	23
Manually adjusting the time offset	24
Activating marriage	24
Change the orientation of the projected image	24
Change the projector host name	25
Change the temperature display	25
Managing the light source	26
Modifying an existing light source Power/LiteLOC™ file	26
Deleting a light source Power/LiteLOC™ file	26
Configuring notifications for lamp alarms	26
Advanced laser power adjustment	26
Adjusting the laser power using JM laser touch panel	27
Managing user accounts	28
Default user access permissions	28
Adding a user account	28
Changing user account permissions	28
Changing a user account password	29
Deleting a user account	29
Network settings	30
Connecting the projector to the theater network	30
Connecting the projector to network attached storage	30
Connecting the projector to a media or content network	31
Activating SNMP	31
Downloading MIB information	31
Setting up an integrated media block	33
Selecting IMB preferences	33
Activating IMB marriage	33
Managing content	34
Content manager icons	34
Ingesting content and keys	34
Canceling an ingest	35
Viewing remaining NAS storage capacity	35
Filtering content by type	35
Viewing available keys	35
Filtering the key list	35

Deleting local content	36
Deleting keys.....	36
Collapsing or expanding columns	36
Viewing content details.....	36
Loading and playing content.....	36
Unloading content	37
Managing playlists	38
Creating a new playlist	38
Reordering playlist content.....	38
Adding a time offset to a macro	38
Replacing playlist content.....	39
Removing playlist content	39
Copying a playlist.....	39
Opening an intermission playlist.....	40
Viewing details about playlist content	40
Importing a playlist	40
Exporting a playlist.....	40
Deleting a playlist	41
Working with channels.....	42
Adding a channel for HDMI input.....	42
Adding a channel for IMB input	43
Editing an existing channel.....	44
Copying existing channel settings to a new channel.....	44
Changing the active channel	44
Viewing the channel list	44
Moving a channel up or down the channel list	45
Deleting a channel	45
Managing color setting files	46
Creating a MCGD file	46
Editing an existing MCGD file.....	46
Copying existing MCGD file settings to a new file.....	46
Deleting a MCGD file.....	47
Creating a TCGD file	47
Editing an existing TCGD file.....	47
Copying existing TCGD file settings to a new file	48

Deleting a TCGD file	48
Adjusting the image size and position.....	49
Activating the Intelligent Lens System	49
Creating a new ILS file.....	49
Calibrating the ILS automatically.....	49
Editing ILS file settings	50
Copying existing ILS file settings.....	50
Deleting an ILS file.....	50
Resetting the lens	50
Creating a source file.....	50
Editing source file settings.....	51
Copying existing source file settings to a new source file.....	51
Deleting a source file	51
Creating a screen file.....	51
Editing screen file settings.....	52
Copying existing screen file settings to a new screen	52
Deleting a screen file	52
Performing digital convergence	53
Resetting digital convergence to the default settings	53
Adjusting the image	54
Correcting keystone effect.....	54
Correcting dual projector horizontal keystone	54
Correcting dual projector vertical keystone.....	55
Correcting vignetting	56
Adjusting vertical boresight	56
Adjusting horizontal boresight	57
Adjusting digital micromirror device convergence.....	58
Adjusting the fold mirror	59
Calibrating the color	59
Masking the screen edges	60
Test patterns.....	61
Displaying a test pattern	61
Turning off a test pattern	61
Importing a test pattern.....	61
Deleting a test pattern.....	61

Working with the scheduler	62
Scheduling a playlist, content, or automation	62
Editing a scheduled event.....	62
Copying and pasting an existing scheduled event	63
Copying and pasting scheduled events for an entire day	63
Cutting and pasting a scheduled event.....	63
Deleting a scheduled event.....	63
Deleting scheduled events for an entire day	64
Changing the day of the week the scheduler starts.....	64
Turning the scheduler off	64
Managing storage devices	65
Adding a new storage device	65
Editing storage device settings.....	65
Setting a storage device as a primary drive	65
Deleting a storage device	66
Adding a remote ingest source.....	66
Editing remote ingest source settings	66
Deleting a remote ingest source.....	66
Managing projector setting files	68
Creating a 3D file	68
Editing an existing 3D file.....	68
Copying a 3D file.....	69
Deleting a 3D file	69
Managing audio settings	70
Setting the global audio delay.....	70
Setting the audio output rate.....	70
Mapping channels	70
Enabling Dolby Atmos.....	71
Editing Dolby Atmos settings	71
Disabling Dolby Atmos.....	71
Setting up multiple projectors	72
Enabling multiple projectors	72
Adding a slave projector.....	72
Enabling content synchronization	72
Disabling multiple projectors	73

Disabling a slave projector	73
Deleting a slave projector	73
Automation	74
Available macro actions	74
Christie ACT actions	75
JNIOR actions	75
Dolby Cinema processor actions.....	76
SKA-3D actions.....	76
Creating a macro	77
Running a macro.....	77
Adding an action item to an existing macro	77
Adding a macro to an existing macro.....	78
Deleting a macro.....	78
Adding an automation device to your auditorium.....	78
Modifying automation device settings	79
Removing an automation device from your auditorium.....	79
Creating a new playlist trigger	79
Editing existing playlist trigger settings.....	80
Deleting a playlist trigger	80
Creating a new global trigger	80
Editing existing global trigger settings	80
Deleting a global trigger.....	81
Importing a device library	81
Viewing a device library	81
Deleting a device library	81
Enhancements and licensing	82
Importing a product enhancement.....	82
Enabling an enhancement	82
Backup, restore, and upgrade projector files	83
Creating a new backup file	83
Exporting a backup file	83
Importing a backup file.....	83
Sorting backup files by name and date created	84
Deleting a backup file	84
Adding an upgrade package	84

Viewing a list of available upgrade files	84
Installing an upgrade package	84
Comparing upgrade packages	85
Deleting an upgrade package	85
Restoring settings from a backup file	85
Restoring factory default settings	85
Accessing projector diagnostics	87
Retrieving and downloading system logs	87
Running the projector interrogator	87
Downloading a certificate	87
Maintaining the projector	89
Inspecting ventilation	89
Inspecting and cleaning optics	89
Recommended service kit	90
Cleaning the lens	90
Inspecting the card cage filter	90
Inspecting the light engine compartment filter	91
Cleaning a washable filter	92
Replacing the lens	93
Troubleshooting	94
Projector functionality	94
Projector does not turn on	94
Cannot establish communication with projector	94
Display issues	94
Flicker, shadows, or dimness	95
Blank screen with no display of cinema image	95
Severe motion artifacts	95
Image is vertically stretched or squeezed	95
Inaccurate display colors	95
Accessing laser system diagnostics	96
Assembling the touch panel	96
Regulatory	97
Safety	97
Electro-magnetic compatibility	97
Emissions	97

Immunity	97
Environmental	98
International packaging recycling mark requirements	98
Appendix	99

Safety precautions

Observe these important safety rules to avoid personal injury or damage to the projector.

This projector must be operated in an environment that meets the operating range, as listed in the projector specifications (on page 32).

General precautions



Warning! If not avoided, the following could result in death or serious injury.

- **TRIP OR FIRE HAZARD!** Position all cables where they cannot contact hot surfaces, be pulled, be tripped over, or damaged by persons walking on or objects rolling over the cables.
- This product must be installed within a restricted access location not accessible by the general public.
- Only personnel who are trained on the precautions for the restricted access location can be granted entry to the area.
- **ELECTRICAL and BURN HAZARD!** Use caution when accessing internal components.
- High leakage current present when connected to IT power systems.
- Possible hazardous optical radiation emitted from this product. (Risk group 3 under IEC 62471-5)
- For protection from ultraviolet radiation, keep all product housings intact during operation.
- **UV EXPOSURE!** Protective UV safety glasses with side shields and Christie approved protective safety clothing must be worn when performing optical adjustments or servicing the product.
- **FIRE AND SHOCK HAZARD!** Use only the attachments, accessories, tools, and replacement parts specified by Christie.
- A minimum of four people or appropriately rated lift equipment is required to safely lift, install, or move the product.



Caution! If not avoided, the following could result in minor or moderate injury.

- Only Christie qualified technicians are permitted to open product enclosures.

AC/power precautions



Warning! If not avoided, the following could result in death or serious injury.

- **SHOCK HAZARD!** A dedicated, protected ground or earth wire must be installed on the product by Christie qualified technicians or electricians before it can be connected to power.
- **SHOCK HAZARD!** Only use the AC power cord provided with the product or recommended by Christie.
- **FIRE AND SHOCK HAZARD!** Do not attempt operation unless the power cord, power socket, and power plug meet the appropriate local rating standards.
- **SHOCK HAZARD!** The AC power cord must be inserted into an outlet with grounding.
- **SHOCK HAZARD!** Do not attempt operation if the AC supply is not within the specified voltage and current, as specified on the license label.
- **SHOCK HAZARD!** Disconnect the product from AC before installing, moving, servicing, cleaning, removing components, or opening any enclosure.
- The appliance coupler and main power supply plug must be easily accessible for disconnecting the product from the power source.



Caution! If not avoided, the following could result in minor or moderate injury.

- Only Christie qualified technicians are permitted to open product enclosures.
- Install the product near an easily accessible AC receptacle.
- For products containing surge suppressors, you must adhere to the installation and power requirements.

Laser safety precautions

Read all safety and warning guidelines before operating the projector laser.



Warning! If not avoided, the following could result in death or serious injury.

- Do not operate the cinema projector without all of its covers in place.
- **LASER RADIATION HAZARD!** This projector has a built-in Class 4 laser module. Never attempt to disassemble or modify the laser module.
- Do not look directly into the lens when the light source is on. The extremely high brightness can cause permanent eye damage.
- Possible hazardous optical radiation emitted from this product. (Risk group 3)

Light intensity hazard distance

This projector has been classified as Risk Group 2 with lenses 108-494108-XX, 108-495109-XX, 108-496100-XX and Risk Group 3 with lens 108-497101-XX as per the IEC62471-5 standard due to possible hazardous optical and thermal radiation being emitted.



Warning! If not avoided, the following could result in death or serious injury.

- **PERMANENT/TEMPORARY BLINDNESS HAZARD!** No direct exposure to the beam must be permitted.
- **PERMANENT/TEMPORARY BLINDNESS HAZARD!** Operators must control access to the beam within the hazard distance or install the product at the height that prevents exposure of spectators' eyes within the hazard distance. The hazard zone must be no lower than 2.5 meters (US installations) or 2.0 meters (global installations) above any surface upon which any persons are permitted to stand and the horizontal clearance to the hazard zone must be a minimum 1.0 meters.
- **EXTREME BRIGHTNESS!** Do not place reflective objects in the product light path.

The following diagram and table show the zones for ocular and skin hazard distances:

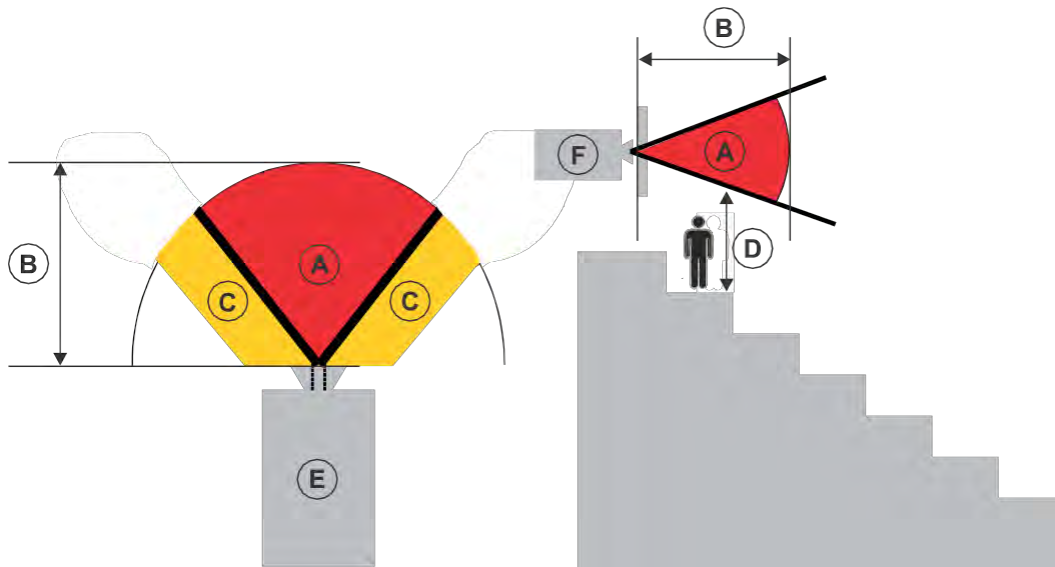

- A—Hazard zone. The region of space where the projection light from the projector is above emission limits for Risk Group 2. The light intensity may cause eye damage after a momentary or brief exposure (before a person can avert his or her eyes away from the light source). The light may cause skin burns to occur.
- B—Hazard distance. Operators must control access to the beam within the hazard distance or install the product preventing potential exposure of the spectators' eyes from being in the hazard distance.
- C—No access zone. Horizontal clearance of the no access zone must be a minimum of 1.0 meters.
- D—Vertical distance to hazard zone. The hazard zone must be no lower than 2.5 meters (US installations) or 2.0 meters (global installations) above any surface upon which any persons are permitted to stand.
- E—Represents the top view of the projector.
- F—Represents the side view of the projector.

Lens	Part number	Hazard distance (m)
1.2-1.72:1, 0.69" DLPCine zoom	108-494108-XX	No hazard distance required
1.33-2.1:1, 0.69" DLPCine zoom	108-495109-XX	No hazard distance required
1.62-2.7:1, 0.69" DLPCine zoom	108-496100-XX	No hazard distance required
2.09-3.9:1, 0.69" DLPCine zoom	108-497101-XX	1.51

For Installations in the United States

The following must be in place for laser-illuminated projector installations in the United States:

- The projection room shall be clearly identified by the posting of laser warning and restricted access signs, and by restricting entry through physical means. The projection room sign must display the warning "No direct exposure to beam shall be permitted".



- The Christie Laser Projection System Installation Checklist must be fully completed after the installation and sent to lasercompliance@christiedigital.com. A copy can remain on-site. This checklist can be found as a separate document in the accessory box with the manual.
- Certain US states have additional laser regulatory requirements. Go to www.christiedigital.com for additional regulatory requirements.

Product labels

Learn about the labels that may be used on the product. Labels on your product may be yellow or black and white.

General hazards

Hazard warnings also apply to accessories once they are installed in a Christie product that is connected to power.

Fire and Shock Hazard	
	To prevent fire or shock hazards, do not expose this product to rain or moisture.
	Do not alter the power plug, overload the power outlet, or use it with extension cords.
	Do not remove the product enclosure.
	Only Christie qualified technicians are authorized to service the product.

Electrical Hazard	
	Risk of electric shock.
	Do not remove the product enclosure.
	Only Christie qualified technicians are authorized to service the product.



General hazard.



Electrocution hazard. To avoid personal injury, always disconnect all power sources before performing maintenance or service procedures.



Hot surface hazard. To avoid personal injury, allow the product to cool for the recommended cool down time before performing maintenance or service.



Burn hazard. To avoid personal injury, allow the product to cool for the recommended cool down time before performing maintenance or service.



Optical radiation hazard. To avoid personal injury, never look directly at the light source.



Moving parts hazard. To avoid personal injury, keep hands clear and loose clothing tied back.



Fan hazard. To avoid personal injury, keep hands clear and loose clothing tied back. Always disconnect all power sources before performing maintenance or service procedures.



Voltage hazard. To avoid personal injury, always disconnect all power sources before performing maintenance or service procedures.



Not for household use.

Mandatory action



Disconnect all power sources before performing maintenance or service procedures.



Consult the service manual.



Disconnect all power sources before performing maintenance or service procedures.

Electrical labels



Indicates the presence of a protective earth ground.



Indicates the presence of an earth ground.

Additional hazard labels



Indicates Class 4 laser radiation when open. Avoid eye or skin exposure to direct or scattered radiation.

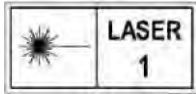

CLASS 1 LASER PRODUCT IEC 60825-1:2014
Wavelengths: 450 nm - 661 nm

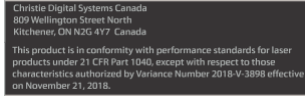

FDA laser variance (US projectors only)

This product is in conformity with performance standards for laser products under 21 CFR Part 1040, except with respect to those characteristics authorized by Variance Number 2021-V-0348 effective on April 18, 2021.

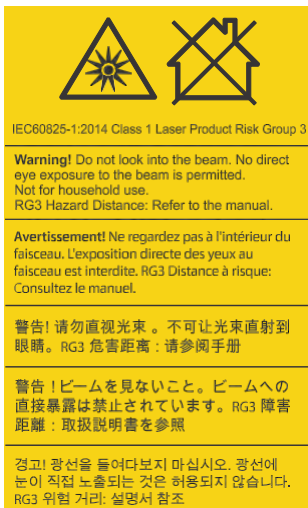

Indicates a light hazard. Do not look directly into the lens. The extreme high brightness can cause permanent eye damage. Class 1 Laser Product - Risk Group 3 according to IEC 60825-1:2014 and IEC 62471-5:2015

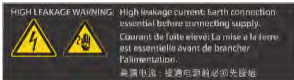

Indicates high leakage current. Earth connection essential before connecting the power supply.



Indicates a light hazard. Do not look directly into the lens. The extreme high brightness can cause permanent eye damage.

Introduction

This manual is intended for operators of Christie CP2306-RGBe, CP2308-RGBe, CP2310-RGBe projection systems.

For complete production documentation and technical support, go to www.christiedigital.com.

Product documentation

For installation, setup, and user information, see the product documentation available on the Christie Digital Systems USA Inc. website. Read all instructions before using or servicing this product.

1. Access the documentation from the Christie website:

Go to <https://bit.ly/3lkZ48l> or

<https://www.christiedigital.com/products/cinema/projection/>

Scan the QR code using a QR code reader app on a smartphone or tablet.



2. On the product page, select the model and switch to the Downloads tab.

Related documentation

Additional information on this product is available in the following documents.

- CP2306-RGBe, CP2308-RGBe, CP2310-RGBe Product Safety Guide (P/N: 020-103453-XX)
- CP2306-RGBe, CP2308-RGBe, CP2310-RGBe Installation and Setup Guide (P/N: 020-103451-XX)
- CP2306-RGBe, CP2308-RGBe, CP2310-RGBe Service Guide (P/N: 020-103454-XX)
- CineLife Serial Commands Guide (P/N: 020-102774-XX)
- CP2306-RGBe, CP2308-RGBe, CP2310-RGBe Specifications Guide (P/N: 020-103452-XX)

Projector overview

The Christie CP2306-RGBe, CP2308-RGBe, CP2310-RGBe is a compact 3DLP cinema projector suited for theaters with screens up to 10.5 meters (35 feet).

The CP2306-RGBe, CP2308-RGBe, CP2310-RGBe provides an improved user interface and enhanced functionality, supporting future higher speed video interfaces. The projector supports all external 3D systems and can be stacked for dual-projection, 3D presentations.

Contact your dealer

Record the information about your installation and keep this information with your records to assist with any servicing of your product. If you encounter a problem, contact your dealer.

Purchase record
Dealer:
Dealer or Christie Sales/Service contact phone number:
Serial number: The serial number can be found on the license label located on the display panel.
Purchase date:
Installation date:

Key features

Understand the important features of the projector.

- Playback of cinema video, audio, and timed text
- Touch panel with 1280 X 800 resolution
- 3D ready
- DCI compliant
- Third-party IMB support
- Motorized lens mount
- High Frame Rate capable
- Standard support for High-bandwidth Digital Content Protection (HDCP)
- Content intake through USB 2.0, USB 3.0, or eSATA ports
- HDMI 1.4
- Support for multi-projector playback
- Simple Network Management Protocol (SNMP) support for remote status monitoring

Understanding the Christie touch panel interface

Use the touch panel to control the projector and perform functions such as turning the light on or off, selecting channels, and viewing status information.



A	Left navigation menu—Access permissions determine the available options.	G	Turns the light on or off.
B	Current access permissions.	H	Opens and closes the douser.
C	Projector name and IP address.	I	Turns test patterns on or off.
D	Current date and time.	J	Displays channels.
E	System status—To display all alarms, tap the colored icon.	K	Displays macros.
F	Turns the projector on or off.	L	Playback controls—See Loading and playing content (on page 32).

Environment

Learn about the operating and non-operating environment requirements for the CP2306-RGBe, CP2308-RGBe, and CP2310-RGBe projectors.

Operating environment

Items	Description
Temperature	10 to 35°C (50 to 95°F) up to 500 m (1640.5 feet)

Humidity (non-condensing)	10% to 80%
Altitude	0 to 3000 m (0 to 9842 feet) at 15 to 25°C (59 to 77°)
Nominal brightness ambient temperature	25°C (77°F)

Non-operating environment

Items	Description
Temperature	-40 to 70°C (-13 to 158°F)
Humidity (non-condensing)	0% to 95%

Technical support

Technical support for Cinema products is available at:

- Support.cinema@christiedigital.com
- +1-877-334-4267
- Professional Services: +1-800-550-3061 or NOC@christiedigital.com

Operating the projector

This section describes how to operate the projector and adjust projector settings. Only the skilled professionals are permitted to operate the projector to ensure safe operation of the device.

Turning the projector on or off

Turn the projector on to display content or turn the projector off to conserve energy.

1. In the right toolbar, tap and hold Power. 

Logging on to the projector

Log on to the projector to access projector menus.

1. Tap Login.
2. In the User list, select a username.
3. Enter your password.
4. Tap Login.

Logging out of the projector

Log out of the projector to restrict access to projector menus or to change access permissions.

1. Tap Logout.

Turning the touch panel on or off

Turn the touch panel on to view projector menus or turn the touch panel off to conserve energy.

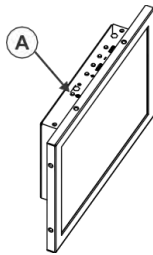

1. To turn the touch panel on or off, on the top of the touch panel, press the Power button (A).

Calibrating the touch panel display

Calibrate the touch panel to improve its appearance and responsiveness to touch commands.

2. Log on to the projector.

3. In the left navigation menu, tap Service Setup > Preferences.
4. Tap Touch Panel.
5. To calibrate the touch panel, tap Start Calibration.

Turning the light source on or off

Turn the light source on to display content or view test patterns, turn the light off to extend the life of the lasers.

6. To turn the light source on or off, in the right toolbar,  tap and hold Light.
If you turn on the light source when the projector power is off, power is turned on automatically.

Opening or closing the douser

Open the douser to display light on the screen or close the douser to remove light from the screen.

1. In the right toolbar, tap and hold Douser. 

Selecting a channel

Create channels to store customized projector settings for different inputs.

2. In the right toolbar, tap Channels. 

The Channels window displays the available channels.

3. Tap a channel.

In the Channel Setup panel, a green checkmark  indicates the active channel.

Adding a network time protocol server

Add a network time protocol (NTP) server to synchronize the time on all installed projectors in the same region.

1. In the left navigation menu, tap Service Setup > Time Setup.
2. Tap the Time Sync using NTP Server slider.
3. The color of the slider changes to green to indicate it is active.
4. Tap + New NTP Server.
5. Select a local or a public NTP server:
6. To use a local NTP server, tap Local Server and type the IP address in the IP Address field.
7. To use a public NTP server, tap Public Server and complete the Country and Server fields.
8. To test the connection, tap Test.
9. Tap Add.

Deleting a network time protocol server

Remove a network time protocol (NTP) server if you do not need to synchronize the time on all installed projectors in the same region.

1. In the left navigation menu, tap Service Setup > Time Setup.
2. If network time protocol (NTP) time synchronization is not active, tap the Time Sync using NTP Server slider.
3. The color of the slider changes to green to indicate it is active.
4. In the NTP Server Address list, tap an NTP server.
5. Tap Delete. 
6. Tap Delete.

Changing the time zone

Change the time zone settings to make the projector time match the local time zone.

1. In the left navigation menu, tap Service Setup > Time Setup.
2. Tap the Time Zone tab.
3. In the Region list, select a region.
4. In the Time Zone list, select the time zone.
5. Select a time format.
6. Tap the Automatically adjust for Daylight Savings slider to automatically adjust the time to daylight savings.
The color of the slider changes to green to indicate it is active.
7. Tap Save.

Changing the time format

Use the 12-hour or 24-hour format to display projector time. The 24-hour format reduces ambiguity.

1. In the left navigation menu, tap Service Setup > Preferences.
2. Tap General.
3. In the System area, select a time format option:
 - To use the 12-hour format, tap 12 Hours.
 - To use the 24-hour format, tap 24 Hours.

Automatically adjusting the time for daylight saving time

With automatically adjusted time settings, there is no need to update the projector time when daylight saving time occurs.

1. In the left navigation menu, tap Service Setup > Time Setup.
2. Tap the Time Zone tab.
3. To automatically adjust the projector time to follow daylight saving time, tap the Automatically adjust for Daylight Savings slider.
The color of the slider changes to green to indicate it is active.
4. Tap Save.

Manually adjusting the time offset

You cannot manually adjust the time offset if network time protocol (NTP) time synchronization is active.



To turn off NTP time synchronization, tap the NTP Servers tab and tap the Time Sync via NTP Server slider. The color of the slider changes to gray to indicate it is inactive.

1. In the left navigation menu, tap Service Setup > Time Setup.
2. Tap the SM Time Adjust tab.
3. Increase or decrease the time offset:

To increase the offset in minutes and seconds, tap Up. ^

To decrease the offset in minutes and seconds, tap Down. v

The Digital Cinema Initiatives (DCI) specification does not allow time offsets greater than six minutes in a calendar year.

4. Tap Save.

Activating marriage

You must complete marriage to display content and to comply with the Digital Cinema Initiatives (DCI) specification. You cannot complete marriage remotely.

5. In the left navigation menu, tap Service Setup > Marriage Setup.
6. Tap Start and complete the Marriage Setup wizard.
7. Tap Finish.

Change the orientation of the projected image

Change the orientation of the projected image from normal to inverted to support multi-projector installations where deflection mirrors are used.

1. In the left navigation menu, tap Service Setup > Preferences.
2. Tap General.
3. From the Projected Image Orientation list, select the required orientation for the projected image

Orientation	Description
-------------	-------------

Normal Front	Projection from behind the audience with the projector in the normal, upright position.
Inverted Front	Projection from behind the audience with the projector in an inverted position (upside down). Inverted positioning is not supported for CP2306-RGBe, CP2308-RGBe, CP2310-RGBe projectors. For more information, see the <i>CP2306-RGBe, CP2308-RGBe, CP2310-RGBe Installation and Setup Manual (P/N: 020-103451-XX)</i> .
Normal Rear	Projection from behind the screen with the projector in the normal, upright position.
Inverted Rear	Projection from behind the screen with the projector in an inverted position (upside down). Inverted positioning is not supported for CP2306-RGBe, CP2308-RGBe, CP2310-RGBe projectors. For more information, see the <i>CP2306-RGBe, CP2308-RGBe, CP2310-RGBe Installation and Setup Manual (P/N: 020-103451-XX)</i> .

Change the projector host name

Change the projector host name to make it easier to identify.

1. In the left navigation menu, tap Service Setup > Preferences.
2. Tap General.
3. In the Projector Hostname field, type a name.
4. Tap Update.

Change the temperature display

Set the touch panel to display temperatures in Celsius or Fahrenheit degrees.

1. In the left navigation menu, tap Service Setup > Preferences.
2. Tap General.
3. In the Temperature Units list, select Celsius or Fahrenheit.

Managing the light source

Learn how to manage the light source.

Modifying an existing light source Power/LiteLOC™ file

Modify the settings in the Lamp Power/LiteLOC™ file to change lamp power.

1. In the left navigation menu, tap Lamp Settings > Lamp Power/LiteLOC Setup.
2. In the Lamp Power/LiteLOC™ File list, select the lamp file to modify.
3. Under Lamp Power, tap the plus and minus signs to modify the power settings for the lamp.
4. Tap Save.

Deleting a light source Power/LiteLOC™ file

Delete a Lamp Power/LiteLOC™ file when it is no longer required.

1. In the left navigation menu, tap Lamp Settings > Lamp Power/LiteLOC Setup.
2. In the Lamp Power/LiteLOC™ File list, select the file to delete.
3. Tap Delete. 
4. To confirm the deletion, tap Delete.

Configuring notifications for lamp alarms

Select the options to receive notification for lamp expiration, lamp half-life, and LiteLOC™ performance issues.

1. In the left navigation menu, tap Service Setup > Preferences.
2. Tap Alarm Triggers.
3. In the right pane, choose from the following options:
 - To receive notification of that the lamp is approaching expiration, tap the Lamp Expiration slider.
 - To receive notification that the lamp is approaching its half-life, tap the Lamp Half-life slider.
 - To receive notification that the configured LiteLOC™ intensity cannot be attained, tap the LiteLOC Intensity Unattainable slider.The slider turns green when the option is activated.

Advanced laser power adjustment

Laser power can be adjusted using the touch panel.

1. In the left navigation menu, tap login.

2. Enter the password.
3. Tap Lamp Setup > Lamp Power/LiteLOC Setup.
4. In Lamp power region, tap the minus (-) or plus (+) signs to decrease or increase the laser power.

Adjusting the laser power using JM laser touch panel

1. In the left navigation menu, tap Background debug.
2. To login, enter password.
3. In the upper navigation menu, tap Light adjustment, then tap the minus (-) or plus (+) signs to decrease or increase the laser power.
4. Tap Save.
The laser power is adjusted.

Managing user accounts

Learn how to create new user accounts, how to modify the properties of those accounts, and how to remove the accounts. A user account is a set of credentials consisting of both a username and password that allows access to a projector setting.

Default user access permissions

This table lists the Christie touch panel access permissions.

Permission	Description
Installer	<ul style="list-style-type: none"> Define Ethernet settings (IP network address). Restore backup files. Upgrade the system software.
Managers	<ul style="list-style-type: none"> Activate channels and test patterns. View detailed diagnostic logs for in-depth troubleshooting. View server errors. <p>This is the default level.</p>
Marriage	<ul style="list-style-type: none"> Access all touch panel windows. Authorize projector marriage.
Operator	<ul style="list-style-type: none"> View basic projector status, diagnostic information and software version information. <p>This is the default level for Serial Communication sessions.</p>
Service	<ul style="list-style-type: none"> Access all touch panel windows. Cannot authorize projector marriage.

Adding a user account

Adding a user account allows users to access projector menus.

1. In the left navigation menu, tap Service Setup > User Accounts.
2. Tap + Add User.
3. Complete the Name, Permissions, New Password, and Confirm Password fields.
4. Tap Add.

Changing user account permissions

Change user account permissions to limit or increase access to projector menus and functionality.

1. In the left navigation menu, tap Service Setup > User Accounts.
2. In the left pane, tap a user account.

3. In the Permissions list, select a new permissions setting.
4. Tap Save.

Changing a user account password

Periodically change a user account password to limit access to projector menus and functionality to authorized users.

1. In the left navigation menu, tap Service Setup > User Accounts.
2. In the left pane, tap a user account.
3. Tap Change password.
4. Complete the New Password and Confirm Password fields.
5. Tap Save.

Deleting a user account

Delete a user account to prevent access to projector menus and functionality.

1. In the left navigation menu, tap Service Setup > User Accounts.
2. In the left pane, tap a user account.
3. Tap Delete. 
4. To confirm the deletion, tap Delete.

Network settings

Learn how to connect the projector to media devices and wired networks.



The system provides the MAC address of the projector automatically.

Connecting the projector to the theater network

Connect the projector to the theater network to control it remotely and allow it to communicate with other network devices.

1. Connect the Ethernet cable from the theater network to the Management port on the input panel.
2. In the left navigation menu, tap Service Setup > Network Settings.
3. In the Port list, tap Management.
4. Enter the network settings:

To obtain the network settings automatically, tap Automatic.

To enter the settings manually, tap Manual and complete these fields:

Field	Description
IP Address	IP address of the projector
Subnet Mask	Subnet mask to which the IP address belong
Gateway	IP address for the network gateway
Primary DNS	IP address of the primary DNS server
Secondary DNS	Te IP address of the secondary DNS server

5. Tap Save.

Connecting the projector to network attached storage

To ingest and play content, a network attached storage (NAS) device must be connected to the projector.

1. Connect the NAS device to the NAS port on the input panel.
2. In the left navigation menu, tap Service Setup > Network Settings.
3. In the Port list, tap Content-NAS.
4. Enter the network settings:

To obtain the network settings automatically, tap Automatic.

To enter the settings manually, tap Manual and complete the IP Address and Subnet Mask fields.

5. Tap Save.

Connecting the projector to a media or content network

Connect the projector to a media or content network to play content.

1. In the left navigation menu, tap Service Setup > Network Settings.
2. In the Port list, tap Media.
3. Enter the network settings:
 - To obtain the network settings automatically, tap Automatic.
 - To enter the settings manually, tap Manual and complete the IP Address and Subnet Mask fields.
4. Tap Save.

Activating SNMP

Activate the Simple Network Management Protocol (SNMP) to monitor the theater network for conditions that indicate communication or hardware failures.

1. In the left navigation menu, tap Service Setup > Network Settings.
2. Tap the SNMP tab.
3. Tap the SNMP slider.
 - The color of the slider changes to green to indicate it is active.
4. In the SNMP Settings area, select a SNMP version.
5. Complete the Trap Receiver IP fields.
 - A trap receiver captures, displays, and logs SNMP traps. Traps are event notices that are sent immediately to the trap receiver from a network device. The SNMP device does not need to use resources to poll for these event notices.
6. In the Blocked SNMP Traps area, select the SNMP traps you want to block.
7. Tap Save.

Downloading MIB information

A Management Information Base (MIB) file contains the definitions for the device being managed by the SNMP protocol.

1. In the left navigation menu, tap Service Setup > Network Settings.
2. Tap the SNMP tab.
3. Tap Download MIB.
4. Browse to the location where you want to save the MIB file.
5. In the Name field, type a name for the MIB file.
6. Tap Accept.

7. Tap OK.

Setting up an integrated media block

Configure CP2306-RGBe, CP2308-RGBe, CP2310-RGBe to work with different models of integrated media blocks, including the Christie IMB.

Selecting IMB preferences

Choose from the available options to set the type of integrated media block (IMB).

1. To set the type of IMB, tap Service Setup > Preferences.
2. Tap IMB.
3. In the type list, select the type of IMB you are using.
The system prompts you to reboot the projector.
4. To apply the changes, tap Reboot.
5. After the projector has restarted, log in with your user account.

Activating IMB marriage

After selecting the IMB type, you must install the IMB and complete marriage to display secure content. You cannot complete marriage remotely.

The marriage wizard requires you to confirm that the IMB has not been tampered with.







1. Install the IMB in the available slot on the projector.
For more information, see the *Christie IMB-S3 Installation and Setup Manual* (P/N: 020-102582-XX) or the documentation provided by the IMB manufacturer.
2. In the left navigation menu, tap Service Setup > Marriage Setup.
3. Tap Start and confirm that the security manager (SM), service door, and marriage ring are secure.
4. Tap Next and complete the marriage checklist, confirming that the following are secure:
All fan clips are tightened on the four-fan pack at the front of the light engine compartment.
Fan-pack spring pins are locked in place to prevent removal of the light engine fan-pack.
Projector front cover is installed.
5. Tap Next and enter the Marriage user and password credentials.
6. Tap Login.
7. To start the marriage process, press the Marriage button on the projector within 30 seconds.
The system starts the marriage process and indicates when the process is completed successfully.
8. Tap Finish.

Managing content

Use the procedures in this section to manage content and keys.

Content manager icons

These icons appear in the content manager.

Icon	Description
	Content is presented in flat format.
	Content is presented in scope format.
2D	2D content identifier.
	3D content identifier.
	Subtitle file is included with the content.
	closed captioning file is included with the content.
2K	2K content identifier.
4K	4K content identifier.
ATMOS	Content includes a Dolby Atmos audio file.
	High frame rate identifier.
	Extended Dynamic Range (EDR) content.

Ingesting content and keys

To ingest content, an ingest device must be connected to the projector. The ingest device must be properly configured and operating correctly.

1. In the left navigation menu, tap Content Manager.
2. Tap the Ingestible Content tab.
3. In the Source list, select a source for the content.
Ingest devices connected to the projector are automatically added to the Source list.
4. Tap Refresh. 
5. In the Show list, select the content type.
6. Select the checkbox to the left of the content you want to ingest or select the empty checkbox at the top of the column to select all content.
7. Tap Ingest.

8. To view the ingest progress, tap the Progress tab.

Canceling an ingest

Cancel an ingest if the ingest is taking too long, or if the content has been ingested previously.

1. Through the Content Manager, run an operation to ingest content and keys.
See *Ingesting content and keys* (on page 30).
2. Tap the Progress tab.
3. Select the checkbox to the left of the content.
4. Tap Cancel.

Viewing remaining NAS storage capacity

View the remaining NAS storage capacity to determine if additional storage is required.

1. In the left navigation menu, tap Content Manager.
2. Review the remaining storage capacity displayed on the Local Content tab.

Filtering content by type

Filter content by type to locate content of a specific type or reduce the return results.

1. In the left navigation menu, tap Content Manager.
2. On the Local Content tab in the Show list, select the content type.

Viewing available keys

Keys are required to play encrypted content.

1. In the left navigation menu, tap Content Manager.
2. To view the available keys, tap the Keys tab.

Filtering the key list

Filter the key list to locate keys of a specific type.

1. In the left navigation menu, tap Content Manager.
2. Tap the Keys tab.
3. In the Show list, select one of the following options for filtering the list:

All Keys

Not Yet Valid

Valid

- Expiring Soon
- Expired

Deleting local content

Delete local content to increase local storage space.

1. In the left navigation menu, tap Content Manager.
2. Select the checkbox to the left of the content on the Local Content tab,
Or select the empty checkbox at the top of the column to select all content.
3. Tap Delete.
4. To confirm the deletion, tap Delete.

Deleting keys

Delete keys when they expire.

1. In the left navigation menu, tap Content Manager.
2. Tap the Keys tab.
3. Select the checkbox to the left of the keys.
4. Tap Delete.
5. To confirm the deletion, tap Delete.

Collapsing or expanding columns

Expand or collapse columns to display more or less information.

1. In the column heading, tap Resize. 

Viewing content details

The Properties panel provides detailed information about the selected content.

1. In the left navigation menu, tap Content Manager.
2. Tap the Local Content tab.
3. Tap Details. 

Loading and playing content

To play content it must be loaded first.

1. Tap and hold Load. 

2. Load local content or a playlist:
 - To load a playlist, tap the Playlists tab.
 - To load locally stored content, tap the Local Content tab.
3. Tap to select the playlist or content.
4. Tap Load.
5. To start playback, tap and hold Play. 

Unloading content

Unload content when it has finished playing and is no longer required.

1. Stop or pause playback. 
2. Tap Unload.

Managing playlists

Use the procedures in this section to manage playlists. A playlist is a list of content files and automated events that play in an order that you define.

Creating a new playlist

A playlist is a list of content files and automated events that play in an order that you define.

1. In the left navigation menu, tap Playlist Editor.
2. In the right pane, tap New Playlist. 
3. In the Create New Playlist dialog, type a name for the playlist and tap Create.
4. Add content or an automation event to the playlist:

To add content to the playlist, tap the content item shown under the Local Content tab.

To add an automation event or macro to the playlist, select a content item in the playlist and then switch to the Automation tab. Tap the automation event or macro item to add it to the playlist.

5. In the right pane, tap Save. 

Reordering playlist content

Reorder the playlist content to change the time when content plays.

1. In the left navigation menu, tap Playlist Editor.
2. In the upper right pane, select a playlist from the list.
3. Tap the content or a macro in the playlist.
4. To select a new position for the content or macro, tap the down arrow and select the number for the new position.

For example, selecting 1 moves the item to the top of the playlist.

5. Tap Save. 

Adding a time offset to a macro



An offset identifies when a macro plays in a playlist.

1. In the left navigation menu, tap Playlist Editor.
2. In the upper right pane, select a playlist.
3. Tap a macro in the playlist and tap Edit. 

4. In Edit Automation dialog, select one of these options from the Offset Type list:
 - To run a macro at a time you define that is offset from the start of the macro you selected in step 3, select After Clip Start.
 - To run a macro at a time you define that is offset from the end of the content you selected in step 3, select Before Clip End.
 - To pause playback, select Before Clip Start. Playback does not resume until the system runs all of the input cues or macros with a time offset value of Before Clip Start. If Before Clip Start is not selected, playback is not paused.
 - If the content contains an FFMC (First Frame Moving Credits) marker, you can also choose the FFMC option to set actions associated with the final credits roll.
5. Under Offset Time, adjust the time the automation occurs.
6. Tap Update.



Replacing playlist content

Replace playlist content when content has been added in error, or you want to add new content to an existing playlist.

1. In the left navigation menu, tap Playlist Editor.
2. In the upper right pane, select a playlist from the list.
3. Tap the content in the playlist.
4. Tap Replace Content. 
5. In the Replace Content dialog, select the new content.
6. Tap Replace.
7. Tap Save. 



Removing playlist content

Remove playlist content when content has been added in error, or you want to update an existing playlist.

1. In the left navigation menu, tap Playlist Editor.
2. In the playlist list in the upper right pane, select the playlist you want to update.
3. Tap content in the playlist.
4. Tap Remove Content. 
5. Tap Save. 

Copying a playlist

Copy a playlist when you want to quickly create a playlist with similar content.

1. In the left navigation menu, tap Playlist Editor.
2. In the playlist list in the upper right pane, select the playlist you want to copy.
3. Tap the menu. 
4. Tap Save As.
5. In the Save Playlist dialog, type a new name for the playlist.
6. Tap Save. 

Opening an intermission playlist

Open an intermission playlist from the top level playlist.

1. In the left navigation menu, tap Playlist Editor.
2. Select the playlist with the intermission item to open.
3. In the right pane, tap the intermission item and then tap Open Intermission Playlist. 

The intermission playlist items are displayed in the right pane.

Viewing details about playlist content

The Details dialog provides detailed information about the selected content.

1. In the left navigation menu, tap Playlist Editor.
2. Under the Local Content tab, to the right of the content, tap Details. 

Importing a playlist

Import a playlist from another projector or computer on the network.

1. In the left navigation menu, tap Playlist Editor.
2. In the right pane, tap the menu. 
3. Tap Import Playlists.
4. In the Import dialog, navigate to the playlist you want to import and select it.
A filter of *.ply is applied automatically to display available playlist files.
5. Tap Accept.

Exporting a playlist

Export an existing playlist to another projector or computer on the network.

1. In the left navigation menu, tap Playlist-Editor.
2. In the right pane, select the playlist you want to export.
3. Tap the menu. 

4. Tap Export-Playlists.
5. In the Export dialog, navigate to the location you want to export to.
6. Tap Export.

Deleting a playlist

Delete a playlist when it is no longer required or when the content has expired.

1. In the left navigation menu, tap Playlist-Editor.
2. In the playlist list in the upper right pane, select the playlist you want to delete.
3. Tap the menu. 
4. Tap Delete.
5. To confirm the deletion, tap Delete.

Working with channels

Create channels to store customized projector settings for different inputs.

Adding a channel for HDMI input

Create a channel to store customized projector settings for input devices connected to the HDMI port.

1. In the left navigation menu, tap Channel Setup.
2. Tap + Add Channel.
3. Complete these fields:

Field name	Description
Name	The channel name
Input Type	Select one of: <ul style="list-style-type: none"> • HDMI Input A • HDMI Input B • HDMI 3D LR • Addon Card • IMB
Data Format	The source color depth (8-10-12 bit) for the channel. If the HDMI source is 2K or greater, select one of: <ul style="list-style-type: none"> • 4K 4:4:4 (RGB) 8 bits • 4K 4:2:2 (YCbCr) 12 bits • 4K 4:2:2 (YCbCr) 10 bits • 4K 4:2:2 (YCbCr) 8 bits
Scan Type	The video scan type. The default is Auto.
3D Sync Input Mode	Specifies whether a specific frame of input data has left eye or right eye data. The default is Auto.
Color Space	The method of color decoding for the current source. The default is Unity RGB for all HDMI sources.
ILS File	ILS file associated with the channel.
2D MCGD File	Measured Color Gamut Data file associated with the 2D image.
3D MCGD Left Eye File	Measured Color Gamut Data file associated with the left 3D image.
3D MCGD Right Eye File	Measured Color Gamut Data file associated with the right 3D image.
TCGD File	Target Color Gamut Data file associated with the channel.
Screen File	The screen type, masking, cropping, and lens settings for the channel.

Gamma File	The gamma correction required for the proper tonal range of the source material.
Clut File	Applies a 3D color cube for increased color accuracy.
3D File	3D settings files associated with the channel.
Source File	The resolution and aspect ratio for the channel.
HDMI EDID	The HDMI standard associated with associated with the channel.
Christie Pureformity Color™ Correction File	The color correction file associated with the channel. The default value is Bypass.

4. Tap Save.

Adding a channel for IMB input

Create a channel to store customized projector settings for input devices connected to the IMB.

1. In the left navigation menu, tap Channel Setup.
2. Tap + Add Channel.
3. Complete these fields:

Field name	Description
Name	The channel name
Input Type	Select IMB.
3D Sync Input Mode	<p>For third party IMBs, specifies how 3D input data is encoded. The default setting is 2D.</p> <ul style="list-style-type: none"> • 2D Mode: No 3D synchronization is applied. • 3D Frame Interleaved: For input that contains left eye data followed by right eye data. • 3D Frame Interleaved Inverted: For input that contains right eye data followed by left eye data. • 3D White Line/Blue Line: For input that includes metadata describing the 3D encoding. • 3D White Line/Blue Line Inverted: For inverted input that includes metadata describing the 3D encoding. • 3D Line Interleaved: The left eye and right eye data are sent on alternating lines. <p>3D Sync Input Mode is not required when using the Christie IMB. For GDC IMB devices, the recommended setting is 3D Line Interleaved.</p>
ILS File	The ILS file associated with the channel.
2D MCGD File	The Measured Color Gamut Data file associated with the 2D image.
3D MCGD Left Eye File	The Measured Color Gamut Data file associated with the left 3D image.
3D MCGD Right Eye File	The Measured Color Gamut Data file associated with the right 3D image.

TCGD File	The Target Color Gamut Data file associated with the channel.
Screen File	The screen type, masking, cropping, and lens settings for the channel.
Gamma File	The gamma correction required for the proper tonal range of the source material.
Clut File	Applies a 3D color cube for increased color accuracy.
3D File	The 3D settings file associated with the channel.
Source File	The resolution and aspect ratio for the channel.
Christie Pureformity Color™ Correction File	The color correction file associated with the channel. The default value is Bypass.

4. Tap Save.

Editing an existing channel

Edit an existing channel when the parameters of the input device change.

1. In the left navigation menu, tap Channel Setup.
2. In the left pane, tap a channel.
3. Edit the channel settings.

Copying existing channel settings to a new channel

Copy a channel to create a new channel with similar settings.

1. In the left navigation menu, tap Channel Setup.
2. In the left pane, tap a channel.
3. Tap Save As.
4. Type a name for the new channel and tap Save.

Changing the active channel

Use the projector touch panel to change the active channel.

1. In the right toolbar, tap Channels. 

The Channels window displays the available channels.

2. Tap the channel you want to activate.

In the Channel Setup panel, a green checkmark indicates the active channel. 

Viewing the channel list

The channel list displays all of the available channels.



1. In the left navigation menu, tap Channel Setup or in the right toolbar, tap Channels. 

The available channels are displayed in the left pane. A green checkmark indicates the active channel.



Moving a channel up or down the channel list

If a channel is selected frequently, move it to the top of channel list to make it easier to access. If the channel is not selected frequently, move it to the bottom of the channel list.

1. In the left navigation menu, tap Channel Setup.
2. In the left pane, tap a channel.
3. To move the channel up or down the list, tap  or .

Deleting a channel

Delete a channel when the settings for the input device are no longer required.



1. In the left navigation menu, tap Channel Setup.
2. In the left pane, tap a channel.
3. Tap Delete. 
4. To confirm the deletion, tap Delete.

Managing color setting files

Use the procedures in this section to manage color setting files. When associated with a channel, a color setting file defines the color output for the content.

Creating a MCGD file

Create Measured Color Gamut Data (MCGD) files to correct on-screen colors. A colorimeter is required to complete this procedure.

1. Turn on the light source and allow it to operate for 20 minutes.
2. In the left navigation menu, tap Color Settings > MCGD File Setup.
3. Tap Create MCGD File. 
4. Type a name for the MCGD file and tap Create.
5. If the MCGD file will be associated with a 3D channel, tap the 3D Sync slider and select a frame rate.
6. In the red area of the chromaticity image, tap the option button to display the red test pattern.
7. Measure the red chromaticity with the colorimeter.
8. Type the red chromaticity value in the X field.
9. Tap Next and type the red chromaticity value in the Y field.
10. Repeat steps 7 to 9 for the green, blue, white, and black chromaticity measurements.
11. Tap Save. 

Editing an existing MCGD file

Edit an existing Measured Color Gamut Data (MCGD) file when on-screen color readings change.

1. In the left navigation menu, tap Color Settings > MCGD File Setup.
2. In the MCGD File list, select a MCGD file.
3. Edit the MCGD file settings.
4. Tap Save. 

Copying existing MCGD file settings to a new file

Copy an existing Measured Color Gamut Data (MCGD) file when you want to create a new MCGD file with similar settings.

1. In the left navigation menu, tap Color Settings > MCGD File Setup.
2. In the MCGD File list, select a MCGD file.

3. Tap Save As. 
4. Type a name for the MCGD file and tap Save.



Deleting a MCGD file

Delete a Measured Color Gamut Data (MCGD) file when it is no longer required.

1. In the left navigation menu, tap Color Settings > MCGD File Setup.
2. In the MCGD File list, select a MCGD file.
3. Tap Delete. 
4. To confirm the deletion, tap Delete.

Creating a TCGD file

Typically, Target Color Gamut Data (TCGD) file settings are defined by the content provider and are not modified. A colorimeter is required to complete this procedure.

1. Turn on the light source and allow it to operate for 20 minutes.
2. In the left navigation menu, tap Color Settings > TCGD File Setup.
3. Tap Create TCGD File. 
4. Type a name for the TCGD file and tap Create.
5. To display test clips automatically when you select a color in the chromaticity image, select
6. Automatically Display Test Clips.
7. To modify the white clipping values and improve image detail in very bright areas of the image, select Use White Clip.
8. Tap the option button in the red area of the chromaticity image to display the red test pattern.
9. Measure the red chromaticity with the colorimeter.
10. Type the red chromaticity values in the Red X and Red Y fields.
11. Adjust the Gain value to modify the color brightness.
12. Repeat steps 8 to 10 for the magenta, blue, cyan, white, yellow, and green chromaticity measurements.
13. To adjust the color of the white light in a specific area of the screen, select White Tolerance and a screen area.
14. Tap Save. 

Editing an existing TCGD file

Edit an existing Target Color Gamut Data (TCGD) file when color readings change.

1. In the left navigation menu, tap Color Settings > TCGD File Setup.

2. In the TCGD File list, select a TCGD file.
3. Edit the TCGD file settings.
4. Tap Save. 

Copying existing TCGD file settings to a new file

Copy an existing Target Color Gamut Data (TCGD) file when you want to create a new TCGD file with similar settings.

1. In the left navigation menu, tap Color Settings > TCGD File Setup.
2. In the TCGD File list, select a TCGD file.
3. Tap Save As. 
4. Type a name for the TCGD file and tap Save.

Deleting a TCGD file

Delete a Target Color Gamut Data (TCGD) file when it is no longer required.

1. In the left navigation menu, tap Color Settings > TCGD File Setup.
2. In the TCGD File list, select a TCGD file.
3. Tap Delete. 
4. To confirm the deletion, tap Delete.

Adjusting the image size and position

Learn how to enable and modify projector image settings.

Activating the Intelligent Lens System







Activate the Intelligent Lens System (ILS) to automatically adjust the position of the lens.

1. In the left navigation menu, tap Service Setup > Preferences.
2. Tap Lens/ILS.
3. In the right pane, tap the ILS Installed slider.

The color of the slider changes to green to indicate the ILS is active.

Creating a new ILS file

Create an Intelligent Lens System (ILS) file to set the X, Y, zoom, and focus positions of the lens.

1. In the left navigation menu, tap Image Settings > ILS File Setup.
2. Tap Create ILS File. 
3. Type a name for the ILS file and tap Create.
4. In the Lens position area, tap the forward, backward, left, or right arrow icons to move the position of the image on the screen.
5. In the Focus area, to increase or decrease image focus, tap Up () or Down () .
6. In the Zoom area, to increase or decrease image zoom, tap Up () or Down () .
7. Tap Save. 

Calibrating the ILS automatically

Use the Auto Calibrate feature of the Intelligent Lens System (ILS) to find and compensate for motor backlash, and to determine the movement range for the currently installed lens.

1. In the left navigation menu, tap Image Settings > ILS File Setup.
2. Tap Create. 
3. Type a name for the ILS file and tap Create.
4. Tap Auto Calibrate.
5. Tap Continue.

Editing ILS file settings

Edit Intelligent Lens System (ILS) file settings when content requirements change.

1. In the left navigation menu, tap Image Settings > ILS File Setup.
2. In the ILS File list, select an ILS file.
3. Modify the ILS file settings.
4. Tap Save. 

Copying existing ILS file settings

To duplicate Intelligent Lens System (ILS) file settings quickly, copy the settings of an existing file to a new ILS file.

1. In the left navigation menu, tap Image Settings > ILS File Setup.
2. In the ILS File list, select the ILS file you want to copy.
3. Tap Save As. 
4. Type a name for the ILS file and tap Save.

Deleting an ILS file

Delete an Intelligent Lens System (ILS) file when it is no longer required.

5. In the left navigation menu, tap Image Settings > ILS File Setup.
6. In the ILS File list, select the ILS file you want to delete.
7. Tap Delete. 
8. To confirm the deletion, tap Delete.



Resetting the lens

Use the Reset Lens feature to have the Intelligent Lens System (ILS) find the home position flags that allow the ILS to compensate for drift over time, or move to its proper position after it has been manually adjusted.

1. In the left navigation menu, tap Image Settings > ILS File Setup.
2. In the ILS File list, select an ILS file.
3. Tap Reset Lens.
4. Tap Continue.

Creating a source file

Create source files to store resolution, offset, and aspect ratio settings for input devices. When the Auto Square Pixels file is selected, the incoming video format is automatically detected.

1. In the left navigation menu, tap Image Settings > Source File Setup.
2. Tap Create Source File. 
3. Type a name for the source file and tap Create.
4. In the Source Media Resolution area, adjust the width and height of the source media.
5. Select an aspect ratio or type a custom aspect ratio for the source media.
6. In the Position area, adjust the horizontal and vertical position of the source media.
7. Tap Save. 

Editing source file settings

Edit source file settings when the settings of the input device change.

1. In the left navigation menu, tap Image Settings > Source File Setup.
2. In the Source File list, select a source file.
3. Modify the source file settings.
4. Tap Save. 

Copying existing source file settings to a new source file

To duplicate existing source file settings quickly, copy the settings of an existing file to a new source file.

1. In the left navigation menu, tap Image Settings > Source File Setup.
2. In the Source File list, select the source file you want to copy.
3. Tap Save As. 
4. Type a name for the source file and tap Save.



Deleting a source file

Delete a source file when it is no longer required.

1. In the left navigation menu, tap Images Settings > Source File Setup.
2. In the Source File list, select the source file you want to delete.
3. Tap Delete. 
4. To confirm the deletion, tap Delete.

Creating a screen file

Use screen files to define the size of the display panel and image cropping. You can assign the same screen file to multiple input devices.

1. In the left navigation menu, tap Image Settings > Screen File Setup.
2. Tap Create Screen File. 
3. Type a name for the screen file and tap Create.
4. To crop the image in a specific location, tap one of the screen icons.
5. To adjust the amount of cropping on the x or y axis, move the slider up or down.
6. To display all image data and maintain the aspect ratio, tap the Letterbox slider.
The color of the slider changes to green to indicate it is active.
7. If required, adjust the Anamorphic Lens Factor value to match the lens installed.
8. Tap Save. 

Editing screen file settings

Edit screen file settings when the image parameters change.

1. In the left navigation menu, tap Image Settings > Screen File Setup.
2. In the Screen File list, select a screen file.
3. Modify the screen file settings.
4. Tap Save. 

Copying existing screen file settings to a new screen

To duplicate screen file settings quickly, copy the settings of an existing file to a new screen file.

1. Tap Image Settings > Screen File Setup.
2. In the Screen File list, select the screen file you want to copy.
3. Tap Save As. 
4. Type a name for the source file and tap Save.

Deleting a screen file

Delete a screen file when it is no longer required.

1. In the left navigation menu, tap Image Settings > Screen File Setup.
2. In the Screen File list, select the screen file you want to delete.
3. Tap Delete. 
4. To confirm the deletion, tap Delete.

Performing digital convergence

Perform digital convergence to improve the quality of the on-screen image.

1. In the left navigation menu, tap Image Settings > Digital Convergence.
2. Tap the up, down, left, or right arrows to adjust the position of the red, green, or blue digital micromirrors (DMDs).

Resetting digital convergence to the default settings

Reset digital convergence to the default settings when image parameters change.

1. In the left navigation menu, tap Image Settings > Digital Convergence.
2. Tap Reset Defaults.

Adjusting the image

Adjust the projector image. Christie recommends warming the lens before completing these procedures as focus may change as the lens warms.

Correcting keystone effect

Learn how to adjust the image to correct keystone effect.

Keystone effect occurs when you project an image onto the screen at an angle. As a result, the image appears distorted and resembles a trapezoid.

If the image suffers from slight keystone effect, it can be corrected with electronic cropping.

If the keystone effect is severe, you can unevenly adjust the feet to compensate for projector tilt. Christie recommends using lens offset to align the center of the image to the center of the screen before you correct the keystone effect.

If one side of the image is longer than another, adjust the tilt and level of the projector.



When making the adjustments, set the light source to minimum power.

Horizontal keystone	Vertical keystone
Projector skewed horizontally to the screen	Projector tilted vertically to the screen

Correcting dual projector horizontal keystone

Learn how to correct horizontal keystone.

1. On both projectors, turn the light source on and open the douser.
2. Align the dual projector images.
3. On the top projector, display the DC2K Framing Green test pattern.

4. On the bottom projector, display the DC2K Framing Red test pattern.
5. Verify that both projectors are level.
6. Identify which projector has the horizontal keystone issue. In this example, the top projector has the horizontal keystone issue.



If both projectors have the horizontal keystone issue, correcting the image on the bottom projector should resolve the issue on both projectors.

7. On the top projector, remove the locking brackets from the projector feet.
8. Move the rear of the top projector to the right or left until the vertical lines are as equally offset as possible.

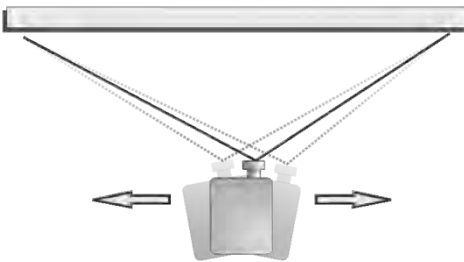

9. Reinstall the locking brackets removed in step 7.
10. On the touch panel, tap the Lens Adjust icon on the main screen and then tap the left or right arrow icons in the Offset area to bring the vertical lines closer together.
11. If required, on each projector, tap the Lens Adjust icon and then tap the left and right focus icons in the Focus area until both images are the same size and focused.

Correcting dual projector vertical keystone

Learn how to correct vertical keystone.

1. On both projectors, turn the light source on and open the douser.
2. Align the dual projector images.
3. On the top projector, display the DC2K Framing Green test pattern.
4. On the bottom projector, display the DC2K Framing Red test pattern.
5. Identify which projector has the vertical keystone issue. In this example, the top projector has the vertical keystone issue.

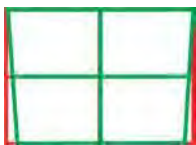

If both projectors have the horizontal keystone issue, correcting the image on the bottom projector should resolve the issue on both projectors.

6. On the top projector, remove the locking brackets from the projector feet.
7. Raise or lower the rear feet of the top projector until the projected images of both projectors are vertically aligned. The feet should be raised or lowered an equal amount.
8. Reinstall the locking brackets removed in step 6.
9. On the touch panel, tap the Lens Adjust icon on the main screen and then tap the forward or backward arrows in the Offset area to bring the horizontal lines closer together.
10. If required, on each projector, tap the Lens Adjust icon and then tap the left focus and right focus icons in the Focus area until both images are the same size and focused.

Correcting vignetting

An image brighter at the center than it is at the sides needs vignetting correction.

If your image suffers from vignetting, the lens has reached the end of its offset travel range. If your installation does not allow the image to be centered with the center of the screen, move the entire projector in the direction of lens travel.

Adjusting vertical boresight

Perform a top and bottom boresight adjustment to fix image focus issues that cannot be corrected by aligning the projector to the screen and focusing the lens.



Caution! If not avoided, the following could result in minor or moderate injury.

- This procedure must be performed by Christie qualified technicians.

Ensure that the projector is perpendicular to the screen before adjusting boresight.

We recommend that you complete a top and bottom boresight adjustment before adjusting the horizontal boresight.

A boresight adjustment should only be made when the image cannot be focused uniformly on the screen by aligning the projector to the screen and focusing the lens. When adjusting boresight, you must maintain the boresight distance from the lens to the prism plane set by Christie. For example, when you move the top screw outward, turn the bottom two boresight screws to maintain the overall distance.

Ensure that the boresight lockdown screws are adequately tightened. Not adequately tightening the boresight screws can result in excessive onscreen image vibration. After adjusting boresight, evaluate the onscreen image vibration and re-adjust if needed.

1. Remove the lens surround.
2. Display the DC2K Boresight test pattern.
3. Loosen the set screw (B).

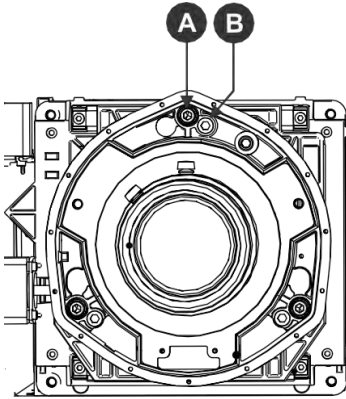

4. Turn the vertical cap screw (A) 1/8 of a turn counter-clockwise.
Only adjust vertical boresight 1/8 of a turn or less at one time to maintain optimal lens performance (factory setup of absolute lens distance to the prism). It is critical that you count each turn of the cap screws to ensure accurate adjustment.
5. Adjust both left and right horizontal adjusters by half the number of turns, in the opposite direction of the vertical adjust.
For example, if the vertical adjust cap screw was turned 1/8 of a turn, the left and right horizontal cap screws should be turned 1/16 of a turn in the opposite direction.
6. Check the screen each time an adjustment is made. If the quality of the projected image has degraded, turn the vertical adjust cap screw 1/8 of turn clockwise. Ensure the left and right horizontal adjusters are adjusted equally in the opposite direction to correct axial focus. The 1/8 of a turn is a suggestion only and can be less if needed; however, it should never be exceeded. Always compensate both left and right horizontal adjustments according to the vertical adjustment.
7. Check the image after each adjustment. Continue to make adjustments until both top and bottom are equally sharp. To make sure the lens is in the same relative position, adjust the left and right horizontal adjusters in the opposite direction at the same time.
8. When the top and bottom of the image are equally in focus lock the set screw to hold it in position. Recheck the image.
9. If additional adjustment is required, try adjusting horizontal boresight.
10. Replace the lens surround.

Adjusting horizontal boresight

Perform a horizontal boresight adjustment when the image cannot be focused uniformly on the screen by aligning the projector to the screen and focusing the lens.



Caution! If not avoided, the following could result in minor or moderate injury.

- This procedure must be performed by Christie qualified technicians.

Typically, horizontal boresight does not require adjustment. It should only be adjusted if a large horizontal angular offset to the screen is required.

When adjusting boresight, you must maintain the boresight distance from the lens to the prism plane set by Christie. For example, when you move the top screw outward, turn the bottom two boresight screws to maintain the overall distance.

Only adjust horizontal boresight 1/8 of a turn or less at one time to maintain optimal lens performance (factory setup of absolute lens distance to the prism). It is critical that you count each turn of the cap screws to ensure accurate adjustment.

Ensure that the boresight lockdown screws are adequately tightened. Not adequately tightening the boresight screws can result in excessive onscreen image vibration. After adjusting boresight, evaluate the onscreen image vibration and re-adjust if needed.

1. Remove the lens surround.
2. Display the DC2K Boresight test pattern.
3. Loosen the right boresight set screw (B).

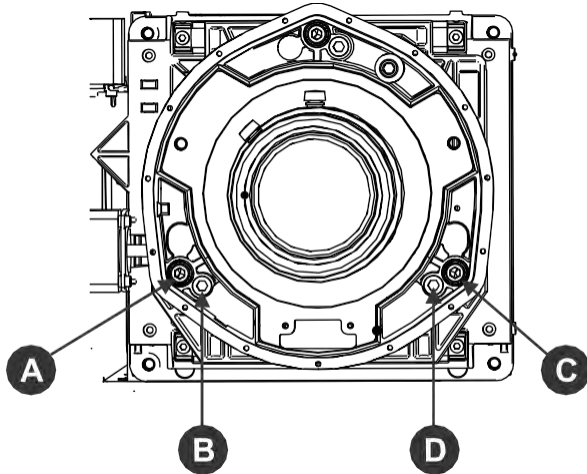

A	Right boresight cap screw	C	Left boresight cap screw
B	Right boresight set screw	D	Left boresight set screw

4. Turn the right boresight cap screw (A) 1/16 of a turn clockwise.
5. Adjust the left boresight cap screw (C) equally in the opposite direction.
6. If the quality of the projected image has not improved, turn the right boresight cap screw 1/16 of turn counter-clockwise. Make sure the left adjuster is adjusted equally in the opposite direction.
7. Check the screen each time an adjustment is made. The right-side adjustments affect the top right and bottom left points on the screen. Once both cross hairs are in focus, lock the set screw for right boresight.
8. Repeat steps 5 to 7 for the left side.
9. Verify that each corner of the screen is equally in focus. If this is not the case, repeat vertical boresight.

Adjusting digital micromirror device convergence

A digital micromirror device (DMD) convergence problem occurs when one or more projected colors (red, green, blue) appears misaligned when examined with a convergence test pattern.

Normally, the three colors should overlap precisely to form pure white lines throughout the image and one or more poorly converged individual colors may appear adjacent to some or all of the lines.

Contact your Christie accredited service technician to correct DMD convergence issues.

Adjusting the fold mirror

Learn how to align the fold mirror with the optical system to correct an image with missing or shadowy corners or edges.

1. Remove the top cover.
2. Display the RGB-12bit-Full Screen White test pattern.
3. Insert a hex driver in the first set screw (A) and a hex driver in the first cap screw (B).

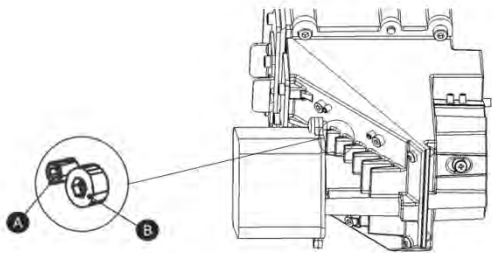

4. Equally turn the set screw (A) and cap screw (B) in opposite directions until the black corner is removed.
5. If the black corner remains, insert a hex driver in the second set screw (C) and a hex driver in the second cap screw (D).

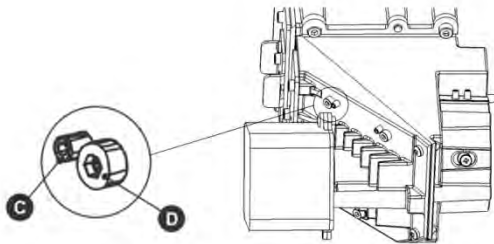

6. Equally turn the set screw (C) and cap screw (D) in opposite directions until the black corner is removed.
7. Replace the top cover.

Calibrating the color

Learn how to create Measured Color Gamut Data (MCGD) files to correct on-screen colors.

Using a colorimeter, measure the colors displayed on the screen from the center of the audience viewing location.

Masking the screen edges

Conceal the unused edges of a screen with top or side masking.

Typically, you install top and side masking to allow a greater range of adjustment.

1. To create top masking:
 - a. Install movable flat black panels or curtains along the top edge of the screen.
 - b. Raise the curtain for flat images or lower the curtain for scope images.

Top-masking theatre (1.85 screens)

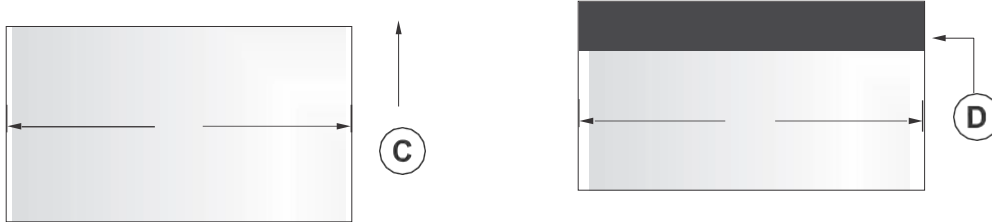

- A 1.85 image
- B 2.39 image
- C Masking moved up
- D Top masking to hide screen top

2. To create side masking:
 - a. Install movable flat black panels or curtains along each side of the screen.
 - b. Close the curtain for flat images or open the curtain and zoom for scope images.

Side-masking theatre (1.85 screens)

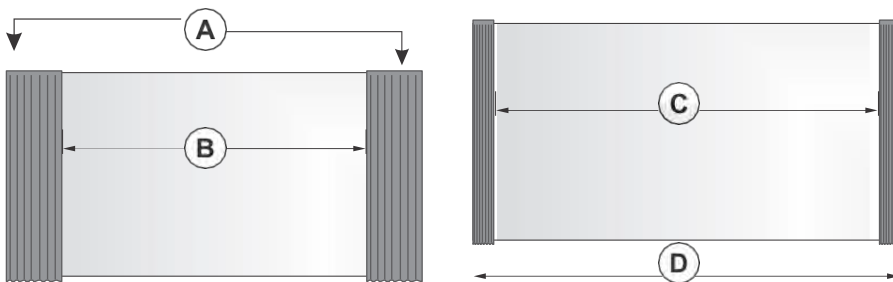

- A Side masking to hide screen edges
- B 1.85:1 image (flat)
- C 2.39:1 image (scope)
- D Masking moved aside

Test patterns

Use the projector to assist with configuration of the projector and to diagnose any issues that may occur.

Displaying a test pattern

Display a test pattern to refine and adjust the projected image or diagnose and correct image issues.

1. In the right toolbar, tap Test Patterns. 
2. Tap Full Screen or Uncorrected Colors.
3. Tap a test pattern.

When a test pattern is active, a blue bar appears below the test pattern icon in the right pane.

Turning off a test pattern

Turn off a test pattern when adjustment of the projected image is complete.

1. Tap Test Pattern Off.

Importing a test pattern

Import custom test patterns to meet the specific requirements of your viewing environment.

1. In the upper right corner, tap Edit.
2. Tap Import.
3. Browse to the location of the test pattern file.
4. Tap the test pattern file.
5. Tap Accept.
6. In the upper right corner, tap Done.

Deleting a test pattern

Delete a test pattern that is no longer required. A test pattern with RGB in the name cannot be deleted.



1. In the upper right corner, tap Edit.
2. Tap a test pattern.
3. Tap Delete.
4. To confirm the deletion, tap Delete.
5. In the upper right corner, tap Done.

Working with the scheduler

Use the scheduler to schedule playlists and automated events to play automatically on a specific date at a specific time.

Scheduling a playlist, content, or automation

Schedule a playlist, content, or automation to run automatically on a specific date and time.

1. In the left navigation menu, tap Scheduler.
2. To enable scheduled events, tap the Auto Playback is OFF slider.
The color of the slider changes to green to indicate it is active.
3. To select a date for the scheduled event, tap Calendar. 
4. Tap a square below the date and next to the time you want the event to run.
5. Tap + New Event.
6. Tap Playlist, Content, or Automation.
7. Tap to select a playlist, content, or automation item.
8. Select the start time.
9. Select the start date.
10. To repeat the event daily, weekly, or monthly:
 - a. Tap the Recurrence slider.
 - b. Select the frequency of the recurrence. The options are daily, weekly, or monthly.
 - c. Select the days or months that you want the playlist, content, or automation event to play.
 - d. To select an end date for the schedule, tap Calendar. 
11. To prevent the scheduled event from being overwritten, tap the Lock Event slider. Locked events cannot be copied or overwritten by pasted events.
12. Tap Create Event.

Editing a scheduled event

Edit a scheduled event to modify the run time and date.

1. In the left navigation menu, tap Scheduler.
2. In the calendar view, tap the scheduled event.
3. Tap Edit.
4. Edit the scheduled event settings.
5. Tap Update Event.

Copying and pasting an existing scheduled event

To run a scheduled event at a different date and time, copy and paste it.

1. In the left navigation menu, tap Scheduler.
2. In the calendar view, tap the scheduled event.
3. Tap Copy.
4. Tap a square below the date and next to the time you want the event to run.
5. Tap Paste.
6. Adjust the any settings for the scheduled event.
7. Tap Paste Event.

Copying and pasting scheduled events for an entire day

To run an existing full day of scheduled events on a different date, copy and paste the entire day of scheduled events.

1. In the left navigation menu, tap Scheduler.
2. At the top of the calendar, tap the day with the events you want to copy.
3. Tap Copy.
4. At the top of the calendar, tap the new target day.
5. Tap Paste.

Cutting and pasting a scheduled event

To move an existing scheduled event to a different date and time, cut and paste it.

1. In the left navigation menu, tap Scheduler.
2. In the calendar view, tap the scheduled event.
3. Tap Cut.
4. Tap the new date in the calendar.
5. Tap Paste.
6. Adjust the settings for the scheduled event.
7. Tap Paste Event.

Deleting a scheduled event

Delete an individual schedule event when it is no longer required.

1. In the left navigation menu, tap Scheduler.
2. In the calendar view, tap the scheduled event.

3. Tap Delete.
4. To confirm the deletion, tap Delete.

Deleting scheduled events for an entire day

Delete the scheduled events for an entire day when they are no longer required.

1. In the left navigation menu, tap Scheduler.
2. At the top of the calendar, tap the target day.
3. Tap Clear Day.
4. To confirm the change, tap Clear Day.

Changing the day of the week the scheduler starts

Change the start day of the scheduler to match the schedule of the theater.

1. In the left navigation menu, tap Service Setup > Preferences.
2. Tap General.
3. In the Scheduler area, select the day of the week to start the scheduler.

Turning the scheduler off

Turn the scheduler off when you do not want scheduled events to run automatically on a specific date and time.

1. In the left navigation menu, tap Scheduler.
2. To disable scheduled events, tap the Scheduler is on slider.
The color of the slider changes to gray to indicate it is inactive.

Managing storage devices

Learn how to add, edit, and remove external storage devices and ingest sources.

Adding a new storage device

Add a new storage device to store and play content.

1. In the left navigation menu, tap **Service Setup > Storage Device Setup**.
2. Tap **+ New Storage Device**.
3. Complete these fields:
 - Name—The name of the storage device.
 - IP Address—The IP address of the storage device.
 - Username—The user account or ID (if required to connect to the storage device).
 - Password—The password for the user account (if required to connect to the storage device).
 - Share Folder—The folder where content is stored.
 - Drive Type—Select **Content Drive** or **Ingest Drive**.
4. To make the content drive the primary storage drive, tap the **Set as Primary Drive** slider. The color of the slider changes to green to indicate it is active.
5. To test the connection to the storage device, tap **Test Connection**.
6. Tap **Save**.

Editing storage device settings

Edit storage device settings when device or communication settings change.

1. In the left navigation menu, tap **Service Setup > Storage Device Setup**.
2. Tap a storage device in the left pane.
3. Edit the settings in the right pane.
4. Tap **Save**.

Setting a storage device as a primary drive

A primary drive is the device that is the primary source of content.

1. In the left navigation menu, tap **Service Setup > Storage Device Setup**.
2. Tap a storage device in the left pane.
3. To make the new storage device the primary storage drive, tap the **Set as Primary Drive** slider.

The color of the slider changes to green to indicate it is active.

4. Tap Save.

Deleting a storage device

Delete a storage device when it is no longer required.

1. In the left navigation menu, tap Service Setup > Storage Device Setup.
2. In the left pane, tap a storage device.
3. Tap Delete. 
4. To confirm the deletion, tap Delete.

Adding a remote ingest source

Add a remote ingest source to uploaded content from a remote storage device.

1. In the left navigation menu, tap Service Setup > Remote Ingest Setup.
2. Tap + New Ingest Source.
3. In the Name field, type a name for the ingest source.
4. In the IP Address field, type an IP address for the ingest source.
5. Tap Add.
6. In the right pane, enter a user name and a password if required for the ingest source.
7. Tap the Type list and select the device type.
8. To test the connection to the ingest source, tap Test Connection.
9. To save the configuration, tap Save.

Editing remote ingest source settings

Edit the settings of remote ingest sources when device or communication settings change.

1. In the left navigation menu, tap Service Setup > Remote Ingest Setup.
2. In the left pane, tap a remote ingest source.
3. Edit the settings displayed in the right pane.
4. Tap Save.

Deleting a remote ingest source

Delete a remote ingest source when it is no longer required.

1. In the left navigation menu, tap Service Setup > Remote Ingest Setup.
2. In the left pane, tap a remote ingest source.



3. Tap Delete. 
4. To confirm the deletion, tap Delete.

Managing projector setting files

Projector setting files store projector settings. When a projector setting file is associated with a channel, the projector settings are automatically adjusted to match the requirements of the content.

Creating a 3D file

Create a 3D file if you are playing 3D content on a single projector or using active 3D with multiple projectors.

1. In the left navigation menu, tap Image Settings > 3D File Setup.
2. Tap Create 3D File. 
3. Type a name for the 3D file and tap Create.
4. In the General Settings area, complete these fields:
 - 3D Delay—Creates a delay to allow the 3D system to synchronize the output and reduce on screen artifacts.
 - Invert 3D Sync Polarity—Reverses 3D stereo sync output (left eye = right eye and right eye = left eye).
5. In the Frame Rate Settings area, complete these fields:
 - Dark Time—Creates a blank time interval in microseconds (μs) between left and right frames to allow for LCD shutter glasses, Z screen, or rotating 3D wheel to synchronize the output.
 - Output Delay—The time interval in microseconds (μs) when an image is not displayed. Offset 3D stereo sync output in relation to the dark time interval. A positive offset adds a delay and a negative offset starts playback early.
 - Phase Delay—The degree of reference between the left and right sync output.
 - Multiplier—Sets the number of frames to display per number of frames that form one complete image. You can increase the display frame rate to reduce flicker from your source.
6. Tap Save. 

Editing an existing 3D file

Edit an existing 3D file to match the settings of the 3D hardware.

1. In the left navigation menu, tap Image Settings > 3D File Setup.
2. In the 3D File list, select a file.
3. Edit the 3D file settings.
4. Tap Save. 

Copying a 3D file

Copy an existing 3D file to create a new 3D file with similar settings.

1. In the left navigation menu, tap Image Settings > 3D File Setup.
2. In the 3D File list, select a file.
3. Tap Save As. 
4. Type a new name for the file.
5. Tap Save.

Deleting a 3D file

Delete a 3D file when it is no longer required.



1. In the left navigation menu, tap Image Settings > 3D File Setup.
2. In the 3D File list, select a file.
3. Tap Delete. 
4. To confirm the deletion, tap Delete.

Managing audio settings

Learn how to enable and modify projector audio settings.

Setting the global audio delay

The global audio delay setting increases or decreases the audio delay.

1. In the left navigation menu, tap Service Setup > Audio Setup.
2. On the Global Settings tab, in the Global Audio Delay area, select one of these options:
 - To increase the audio delay, tap Up. 
 - To decrease the audio delay, tap Down. 

Setting the audio output rate

Adjust the audio output rate to match the output of the audio device.

1. In the left navigation menu, tap Service Setup > Audio Setup.
2. On the Global Settings tab, in the Audio Output Rate area, select one of these options:
 - Automatic
 - 48 kHz
 - 96 kHz

Mapping channels

Use the Channel Mapping tab to map the Digital Cinema Package (DCP) audio channels to the AES outputs. Interop is the most common audio setting.

1. In the left navigation menu, tap Service Setup > Audio Setup.
2. Tap the Channel Mapping tab.
3. In the Channel Format list, select an audio format.

The selection in the Channel Format list does not determine the audio format. The content determines the audio format. For example, if you select SMPTE 7.1 DS and Interop is specified in the content, the Interop audio settings are applied when the content plays.

4. Select the channel that matches the speaker specified in the *Interop Channel Mapping Guide*.
5. For any speakers not being used, select Not Used.
6. To test the channel mapping setting, tap Test.

Enabling Dolby Atmos

To play content with Dolby Atmos audio, enable Dolby Atmos.

1. Tap Service Setup > Audio Setup.
2. Tap the Dolby Atmos Configuration tab.
3. Tap the Enable Dolby Atmos slider.
The color of the slider changes to green to indicate it is active.
4. In the Control IP field, type the control IP address.
5. In the Input IP field, type the input IP address.
6. To test Dolby Atmos connectivity, tap Test Connection.
7. Tap Save.

Editing Dolby Atmos settings

Edit Dolby Atmos settings when device settings change.

1. Tap Service Setup > Audio Setup.
2. Tap the Dolby Atmos Configuration tab.
3. Edit the Control IP and Input IP fields.
4. To test Dolby Atmos connectivity, tap Test Connection.
5. Tap Save.

Disabling Dolby Atmos

Disable Dolby Atmos when Dolby Atmos audio playback is no longer required.

1. Tap Service Setup > Audio Setup.
2. Tap the Dolby Atmos Configuration tab.
3. Tap the Enable Dolby Atmos slider.
The color of the slider changes to gray to indicate it is inactive.
4. Tap Save.

Setting up multiple projectors

Learn how to add, modify, and remove master and slave projectors.

Enabling multiple projectors

Enable multiple projectors to display 3D or HDR content.

1. In the left navigation menu, tap Service Setup > Multi-Projector Setup.
2. Tap the Multi-Projector Control slider.
The color of the slider changes to green to indicate it is active.
3. Tap the Active 3D Glasses slider if using active 3D glasses and want to send left and right images to multiple projectors.
If you select this option, you cannot change the eye selection setting.
4. In the Master Eye Selection list, select Right or Left for the master projector.
This option is not available when you select Active 3D Glasses.

Adding a slave projector

Add a slave projector to display 3D or HDR content.

1. In the left navigation menu, tap Service Setup > Multi-Projector Setup.
2. Tap New Slave Projector.
3. This option is available only when the Multi-Projector Control slider is selected.
4. Type a name and an IP address for the projector.
5. Tap Add.
6. In the Eye Selection column, select Right or Left.

Enabling content synchronization

Complete this procedure on the master projector.

Content synchronization is supported for Christie network attached storage (NAS) devices only. To synchronize content, you must also enable the Multi-Projector Control option on the master projector.



To enable content synchronization, you must set up a network connection between NAS devices. For detailed information, see the documentation provided with the Christie NAS.

1. On the master projector touch panel, tap Service Setup > Multi-Projector Setup.
2. Under Master Projector Settings, tap Multi-Projector Sync of Content.

The color of the slider turns to green to indicate content synchronization is active. When enabled, ingested content on the master projector is synchronized to all slave projectors automatically.

Disabling multiple projectors

Disable multi-projector settings when the second projector is not required to display content.

1. In the left navigation menu, tap Service Setup > Multi-Projector Setup.
2. Tap the Multi-Projector Control slider.

The color of the slider changes to gray to indicate it is inactive.

Disabling a slave projector

Disable a slave projector when it is no longer required or when it is replaced by another projector.

1. In the left navigation menu, tap Service Setup > Multi-Projector Setup.
2. Tap the slider in the Enabled column of the slave projector you want to disable.

The color of the slider changes to gray to indicate it is inactive.

Deleting a slave projector

Delete a projector from a multi-projector configuration when it is no longer required or when it is replaced by another projector.

1. In the left navigation menu, tap Service Setup > Multi-Projector Setup.
2. In the Delete column of the slave projector you want to delete, tap Delete. 
3. To confirm the deletion, tap Delete.

Automation

You use automation to control playback, the projector, and external devices. This section provides instructions for managing and defining:

- **Macros**-A macro is a list of actions that you define. For example, opening the curtains or turning on the house lights at the end of playback. A macro can be activated by a global trigger, or it can be added to a playlist.
- **Device Input Triggers**-Input cues wait for events such as a general purpose input (GPI) state change or an Ethernet message received on TPC port 5111. An input cue in a playlist delays playback until an event occurs.
- **Global Triggers**-A global trigger combines an input cue with a macro. When the predefined event for the input cue occurs, the output macro is triggered. For example, a fire alarm input signal could cause playback to stop and the house lights to come on. A global trigger is always active and is not dependent on specific playlist definitions.

Available macro actions

These are the macro actions that are available to control automated events:

Action item	Available actions	Description
Automation	Set Global	Allows you to set a global variable that can be used in automation scripting (intended for advanced scripting by Christie)
	Print	Generates a projector log entry when an automation macro runs
	Get Global	Allows the automation script to read the value of a global variable (intended for advanced scripting by Christie)
	Set GPO	Sets the specified GPO pin to high or low
	Pulse GPO	Pulses the specified GPO pin
	Get GPI	Allows an automation script to read the GPI state (intended for advanced scripting by Christie)
	Delay	Delays macro execution
	Wait On GPI	Pauses the automation script and waits for the specified GPI event to enter the specified state
Playback	Pause	Pauses playback
	Stop	Stops playback
	Play	Starts or resumes playback
	Toggle	Pauses playback if content is playing OR resumes playback if content is paused
	Disable Subtitle	Disables subtitles for the current content and onward

	Jog	Moves content forward by the time specified
Projector	Douser Open	Opens the douser
	Douser Close	Closes the douser
	Light On	Turns the light on
	Light Off	Turns the light off
	Standby	Puts the projector in standby mode
	Channel	Selects a specific projector channel
	Revert Warp File	Reverts a modified warp file to the default settings
	Full Power	Places the projector in full power mode (douser open, light on)
	Wait	Delays the execution of a macro
	Disable Subtitle	Disables subtitles for the current content and onward
	Jog	Moves content forward by the time specified

Christie ACT actions

These are the available built-in commands for the Christie ACT:

Command	Description
Buzzer	Activates the buzzer for the specified time (in milliseconds)
Button	Simulates pressing or holding the ACT button
Pulse Relay	Sends a pulse to a specific relay
Open Relay	Opens a specific relay
Close Relay	Closes a specific relay
Pulse GPO	Sends a pulse to a specific GPO pin
Set All GPOs	Sets the values for all GPO pins
Run Script	Runs a script on the Christie ACT
Flash LED	Causes a specific LED to flash
Set All LEDs	Sets values for all of the LEDs

JNIOR actions

These are the available built-in commands for JNIOR devices:

Command	Description
Open Relay	Opens a specific JNIOR relay
Close Relay	Closes a specific JNIOR relay
Pulse Relay	Sends a pulse to a specific JNIOR relay for the specified time (in milliseconds)
Execute Macro	Executes a JNIOR macro

You can create macros on the JNIOR device and call them using the Execute Macro command. Make sure you use \0D for a carriage return and \0A for a line feed.

To create and run macros on the JNIOR, use the JNIOR Support Tool to enable and configure the Cinema.JNIOR application. It is recommended that you install Cinema.JNIOR version 2.22.1115.1501 or later. For additional information, see INTEG Process Group (www.integpg.com). Port 9200 is the default Ethernet port for sending automation commands to the JNIOR.

Dolby Cinema processor actions

These are the available built-in commands for Dolby CP650, CP750, and CP850 devices:

Command	Description
Mute On/Mute Off	Enables or disables muting
Set Format (CP650 only)	Selects the format
Set Fader Level	Sets the fader level
Send Message (CP850 only)	Sends the specified message

If you need to control additional functions and a built-in command is not available, send a command string in a macro. For example, send this command to enable surround boost on the Dolby CP750:

```
cp750.sys.surround_boost 1\0D
```

Make sure that you include a carriage return (\0D) at the end of each command. For more information about controlling other features with serial commands, see the Dolby CP750 documentation.

The default Ethernet port for sending automation commands to the Dolby CP650 is port 61412. For Dolby CP750 and CP850, the default Ethernet port is port 61408.

SKA-3D actions



These are the available built-in commands for SKA-3D devices:

Command	Description
Set Audio Input Channel	Sets the audio input channel
Mute On/Mute Off	Enables or disables muting
Set Master Volume	Sets the master volume for the system

Set Video Input Channel	Sets the video input channel
Active Trigger Input	Controls eight SKA-3D presets To use this command, a trigger input must be associated with each of the SKA-3D presets

Creating a macro

Create a macro to make the projector perform a specific list of actions.

1. In the left navigation menu, tap Automation > Macro Editor.
2. In the right pane, tap Create New Macro. 
3. Type a name for the macro.
4. Select the macro type.
5. Tap Create.
6. Add an action item to the macro:
 - a. In the left pane, expand the My Auditorium list.
 - b. Select the type of device the macro will apply to.
 - c. Tap the action item.
7. To test the macro, tap Test.
8. Tap Save. 

Running a macro

Run a macro to make the projector perform a specific list of actions.

1. In the right toolbar, tap Run Macro. 
2. Tap a macro.

Adding an action item to an existing macro

Add an action item to a macro to have the projector perform an additional action when the macro runs.

1. In the left navigation menu, tap Automation > Macro Editor.
2. In the top right pane, select a macro from the list.
3. Add an action item to the macro:
 - a. In the left pane, expand the My Auditorium list.
 - b. Under Automation, Playback, or Projector, select the action item.
4. To save the macro, tap Save. 
5. To test the macro, tap Test.

Adding a macro to an existing macro

Combine macros to have the projector complete a complex set of actions.

1. In the left navigation menu, tap Automation > Macro Editor.
2. From the list in the top right pane, select a macro.
3. In the left pane, expand the macro list.
4. Tap a macro.
5. Tap Save. 

Deleting a macro

Delete macros when they are no longer required.

1. In the left navigation menu, tap Automation > Macro Editor.
2. From the list in the top right pane, select a macro.
3. Tap Delete. 
4. To confirm the deletion, tap Delete.

Adding an automation device to your auditorium

Add an automation device so it can be controlled remotely and can communicate with other theater hardware.

1. In the left navigation menu, tap Automation > My Auditorium Devices.
2. Tap + New Device.
3. In the Name field, type a name for the device.
4. In the Device Type list, select the device type.
5. In the Select Device list, select the device.
6. Tap Add.
7. Complete these fields:

IP Address—The IP address of the automation device.

Port—The port used by the automation device to communicate with the projector.

Username—The username used to access the automation device.

Password—The password used to access the automation device.

Keep Alive Message—The message value that is sent to the automation device to ensure the projector is not disconnected when inactive.

Keep Alive Interval (ms)—The time interval (in microseconds) for sending the Keep Alive Message to the automation device.

8. Tap Save.

Modifying automation device settings

Modify the settings of automation devices when parameters such as the user name or password change. If the settings are not updated, the automation device might be unable to communicate with other theater hardware or be controlled remotely.

1. In the left navigation menu, tap Automation > My Auditorium Devices.
2. In the left pane, select an automation device.
3. Modify these fields:

IP Address—The IP address of the automation device.

Port—The port used by the automation device to communicate with the projector.

Username—The username used to access the automation device.

Password—The password used to access the automation device.

Keep Alive Message—The message value that is sent to the automation device to ensure the projector is not disconnected when inactive.

Keep Alive Interval (ms)—The time interval (in microseconds) for sending the Keep Alive Message to the automation device.

4. Tap Save.

Removing an automation device from your auditorium

Remove an automation device when it is no longer required, or it has been physically removed from the theater.

1. In the left navigation menu, tap Automation > My Auditorium Devices.
2. In the left pane, select an automation device.
3. Tap Delete. 
4. To confirm the deletion, tap Delete.

Creating a new playlist trigger

Create new playlist triggers to activate an automation device in a playlist.

1. In the left navigation menu, tap Automation > Device Input Triggers.
2. Tap the Playlist Trigger tab.
3. Tap + New Playlist Trigger.
4. Complete the Name, Device Source, and Resume Playback On fields.
5. Tap Add.

Editing existing playlist trigger settings

Edit playlist trigger settings to change the playlist trigger behavior.

1. In the left navigation menu, tap Automation > Device Input Triggers.
2. Tap the Playlist Triggers tab.
3. To the right of the playlist trigger you want to edit, tap Edit. 
4. Edit the playlist trigger settings.
5. Tap Save.

Deleting a playlist trigger

Delete a playlist trigger when it is no longer required.

1. Tap Automation > Device Input Triggers.
2. Tap the Playlist Triggers tab.
3. To the right of the playlist trigger, tap Delete. 
4. To confirm the deletion, tap Delete.

Creating a new global trigger

Create a global trigger to trigger an output macro. For example, a fire alarm input signal could cause playback to stop and the house lights to come on. A global trigger is always active and is not dependent on specific playlist definitions.

1. In the left navigation menu, tap Automation > Device Input Triggers.
2. Tap the Global Triggers tab.
3. Tap + New Global Trigger.
4. Complete the Name, Source, and Trigger Event fields.
5. In the Macro Name list, tap the macro that will run on trigger detection.
6. Tap Add.

Editing existing global trigger settings

Edit the settings of an existing global trigger to change its behavior.

1. In the left navigation menu, tap Automation > Device Input Triggers.
2. Tap the Global Triggers tab.
3. To the right of the global trigger you want to edit, tap Edit. 
4. Edit the global trigger settings.
5. Tap Save.

Deleting a global trigger

Delete a global trigger when it is no longer required.

1. In the left navigation menu, tap Automation > Device Input Triggers.
2. Tap the Global Triggers tab.
3. To the right of the global trigger, tap Delete. 
4. To confirm the deletion, tap Delete.

Importing a device library

A device library contains commands used to control a specific device.

1. In the left navigation menu, tap Automation > Device Libraries.
2. Tap Import Device Library.
3. Browse to the location of the device library file.
4. Tap the file and tap Accept.

Viewing a device library

View device libraries to determine if a library exists for the network device.

1. Import the device library.
2. In the left navigation menu, tap Automation > Device Libraries.
3. To the right of the device in the View Library column, tap View Library. 
4. Review the list of actions available for the device.

Deleting a device library

Delete a device library when it is no longer required.

1. In the left navigation menu, tap Automation > Device Libraries.
2. To the right of the device library, tap Delete. 
3. To confirm the deletion, tap Delete.

Enhancements and licensing

Learn about importing licenses and activating product enhancements.

Importing a product enhancement

Import a license to activate a product enhancement.

1. Tap Service Setup > Enhancements.
2. Tap Import License.
3. Browse to the location of the license.
4. Select the license and tap Accept.

Enabling an enhancement

After importing a license, it must be enabled to activate the new functionality.

1. Tap Service Setup > Enhancements.
2. *Import the license* (on page 80).
3. Tap the Enhancement slider.

The color of the slider changes to green to indicate it is active.

Backup, restore, and upgrade projector files

Learn how to back up, restore, and upgrade projector files.

Creating a new backup file

Create a new backup file to restore projector settings if a failure occurs.

1. In the left navigation menu, tap Service Setup > Backup and Restore.
2. Tap New Backup.
3. Type a name for the backup file.
4. Tap Backup.

Exporting a backup file

A disaster recovery plan can include exporting backup files to another location.

1. In the left navigation menu, tap Service Setup > Backup and Restore.
2. Insert a USB flash drive into the Management USB port on the projector communication board.
3. Select a backup file and tap Export .
4. Tap to move up through the file directory.
5. Tap to create a new folder.
6. In the Name field, type a name for the backup file.
7. Tap Accept.

Importing a backup file

Import a backup file to restore projector settings.

1. In the left navigation menu, tap Service Setup > Backup and Restore.
2. Insert a USB flash drive into the Management USB port on the projector communication board.
3. Tap Import Backup.
4. Browse to the location of the file or enter a name for the backup file in the Name field.
5. Select the file and tap Accept.

Sorting backup files by name and date created

Locate a backup file with a specific name or creation date.

1. In the left navigation menu, tap Service Setup > Backup and Restore.
2. Sort the backup files:
 - To sort the backup files by name, tap the Backup File Name heading.
 - To sort the files by the date they were created, tap the Date Created heading.

Deleting a backup file

Delete a backup file if it is no longer required or is uploaded in error.

1. In the left navigation menu, tap Service Setup > Backup and Restore.
2. Select a backup file and tap Delete. 
3. To confirm, tap Delete.

Adding an upgrade package

An upgrade package is used to upgrade the projector software.

A maximum of 10 upgrade packages can be stored. When you add an upgrade package exceeding this limit, the system deletes the upgrade package last used.

1. In the left navigation menu, tap Service Setup > System Upgrade.
2. Tap + Add New Package.
3. Browse to the location of the upgrade package.
4. Type a name for the upgrade package and tap Accept.

Viewing a list of available upgrade files

Select a specific upgrade file to install from a list of upgrade files.

1. In the left navigation menu, tap Service Setup > System Upgrade.
 - A list of upgrade files appears in the left pane.

Installing an upgrade package

Install an upgrade package to update the projector software.

1. In the left navigation menu, tap Service Setup > System Upgrade.
2. In the list of packages, tap an upgrade package.
3. In the right pane, select one of these options:

Upgrade Differences Only—Upgrades system components that are newer or older than the currently installed version.

Force Upgrade All—Upgrades all components in the upgrade package.

Factory Upgrade—Removes all existing configurations and upgrades all components.

4. Tap Upgrade.
5. To confirm, tap Upgrade.

Comparing upgrade packages

Compare upgrade packages to view the differences between them.

1. In the left navigation menu, tap Service Setup > System Upgrade.
2. In the list of packages, tap an upgrade package.

The differences between the current and the selected upgrade package are displayed in the right pane. Differences are identified with a yellow exclamation mark.

Deleting an upgrade package

Delete an upgrade package that is no longer required.

1. In the left navigation menu, tap Service Setup > System Upgrade.
2. In the list of packages, tap an upgrade package.
3. Tap Delete. 
4. To confirm the deletion, tap Delete.

Restoring settings from a backup file

Restore projector settings from a backup file.

1. In the left navigation menu, tap Service Setup > Backup and Restore.
2. Select a backup file and tap Restore. 
3. Select the settings you want to restore and tap Restore.
4. Tap OK.

Restoring factory default settings

Restoring factory settings removes all custom projector settings.

1. In the left navigation menu, tap Service Setup > Backup and Restore.
2. Tap Factory Restore.
3. Select the settings you want to restore and tap Restore.

4. Tap OK.

Accessing projector diagnostics

Learn how to access projector system logs and run diagnostic utilities.

Retrieving and downloading system logs

System logs can aid with the identification and correction of projector faults.

1. In the left navigation menu, tap Diagnostics > System Logs/Interrogator.
2. In the From list, select a start date for the logs.
3. In the To list, select an end date for the logs.
4. In the Log Source list, select a log type.
For example, Projector.
5. Tap Search.
6. To sort log files by type, message, or date, tap a column heading.
7. To download the SM report:
 - a. Tap Download SM Report.
 - b. Browse to the location where you want to save the report file.
 - c. Type a name for the report file in the Name field.
 - d. Tap Accept.

Running the projector interrogator

Run the interrogator to identify and correct projector faults.

1. Insert a USB flash drive in the Management USB port on the projector communication board.
2. In the left navigation menu, tap Diagnostics > System Logs/Interrogator.
3. Tap Run Interrogator.
4. Tap Interrogate.
5. Browse to the location where you want the interrogator file to be saved.
6. In the Name field, type a name for the interrogator file.
7. Tap Accept.

Downloading a certificate

Use a certificate to request Key Delivery Message (KDM) keys.

1. In the left navigation menu, tap About.

2. In the certificate list, select one of the following certificates:
 - Projector Certificate
 - SMS Certificate
 - SM Certificate (used by distributors to generate KDM keys)
 - Log Signer Certificate
3. Tap Download.
4. In the Name field, type a name for the certificate file.
5. Tap Accept.

Maintaining the projector

Learn the information and procedures for performing projector maintenance.

Read through this section in its entirety before performing maintenance activities. When performing projector maintenance, obey all warnings and precautions.



Warning! If not avoided, the following could result in death or serious injury.

- SHOCK HAZARD! Disconnect the product from AC before installing, moving, servicing, cleaning, removing components, or opening any enclosure.
- Do not operate the cinema projector without all of its covers in place



Caution! If not avoided, the following could result in minor or moderate injury.

- Christie products must be installed and serviced by Christie qualified technicians.
- Only Christie qualified technicians are permitted to open product enclosures.



Notice. If not avoided, the following could result in property damage.

- Observe all electrostatic precautions. Use a grounded wrist strap and insulated tools when handling, servicing, or cleaning electronic assemblies.
- Always wear clean, powder-free latex gloves when handling optical components.

Inspecting ventilation

Vents and louvers in the projector covers provide ventilation, both for intake and exhaust.

Never block or cover these openings. Do not install the projector near a radiator, heat register, or within an enclosure.

To ensure adequate airflow **around the projector, keep a minimum clearance of 50cm (19.69") on the left, right, and rear sides of the projector.**

Inspecting and cleaning optics

Inspect and clean optical components such as the projection lens to ensure optimum image display.

Unnecessary cleaning of optics can increase the risk of degrading delicate coatings and surfaces. A small amount of dust or dirt on the lens has minimal effect on image quality-to avoid the risk of scratching the lens, clean the lens only if absolutely required.

Typically, optical components do not need to be cleaned frequently if they are installed and operated in a location that meets or exceeds the environmental standard recommended by Christie. Christie recommends that all cinema projectors are installed and operated in an environment that meets or exceeds Underwriters Laboratories (UL) standard 609.50 Pollution Degree 2 and ISO Class 9 Standard for Office Environments.



Notice. If not avoided, the following could result in property damage.

- Christie products must be installed and serviced by Christie qualified technicians.
- Do not reuse lens tissues.

- Always handle optics by their edges.

Recommended service kit

Use the following recommended tools to clean the optics.

- Powder-free latex gloves
- Soft camel-hair brush
- Dust-free blower - air bulb or a canned air duster without additives such as Techspray 1671- 10S Ultra-Pure Duster
- Lint-free lens tissue, such as Lensx 90 tissue or Newport Optics cleaning tissue
- Lens cleaning solution and a microfiber cloth (for the lens only)
- Optical grade cotton swabs with wooden stems
- A bright, portable illumination device such as an LED flashlight

Cleaning the lens

To avoid the risk of scratching the lens, clean the lens only if absolutely required.

Inspecting the card cage filter

Check the condition of the card cage air filter monthly. Clean or replace the card cage air filter sooner if you are operating the projector in a dusty or dirty environment.

The filter is located on the left side of the projector behind the air filter cover. Use only high efficiency Christie approved filters.

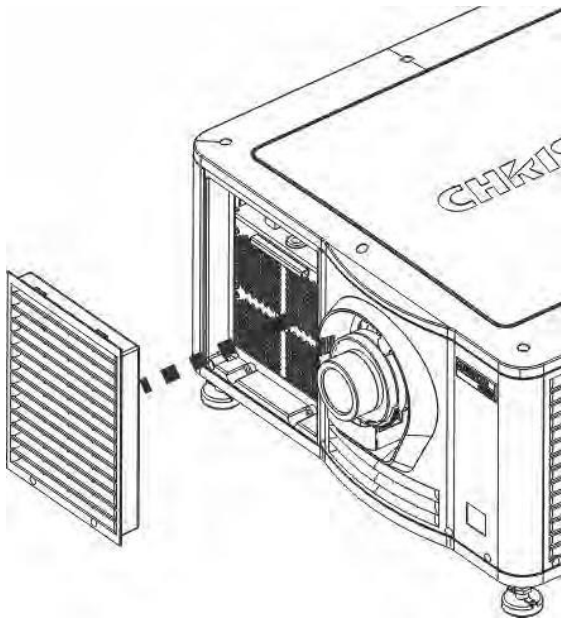



Caution! If not avoided, the following could result in minor or moderate injury.

- Do not operate the product without the filter installed.
- Do not reuse an old air filter.

1. Loosen the two captive screws on the bottom of the filter cover.
2. Pull the cover out and down.
3. Slide the air filter out and inspect it.

If the filter appears dirty and you cannot see through it, *clean it* (on page 90) if it is a washable filter.

If the filter appears clean, continue to step 4.

4. Replace the air filter with the airflow indicator facing toward the projector.
5. Install the air filter cover by inserting the two bottom tabs and then pushing the cover closed.
6. Tighten the two captive screws.

Inspecting the light engine compartment filter

The filter is located on the right side of the projector behind the service access panel.

1. Remove the top lid.
2. Reach into the projector and then loosen the first service panel screw.
3. Open the integrator rod access door and loosen the second service panel screw.
4. Push the clips on the top of the service panel down and out to remove the service panel.

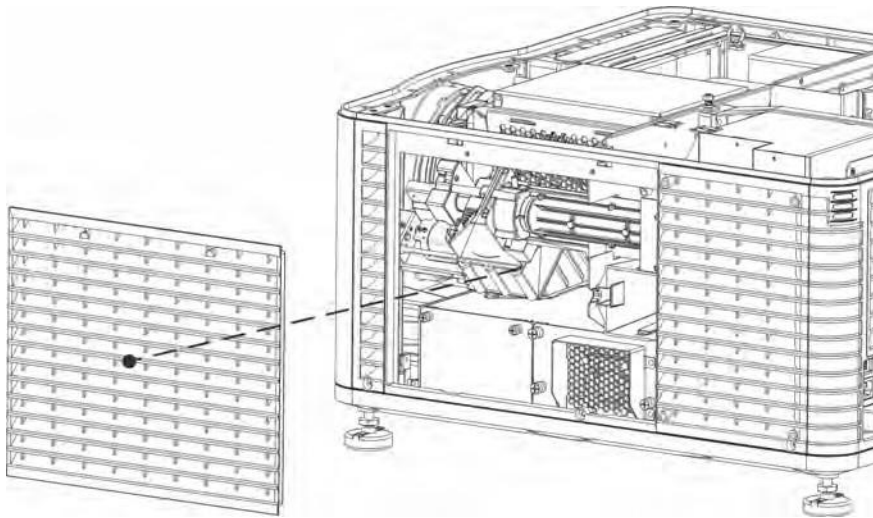

5. Loosen the two captive screws on the cap plate and then remove it.

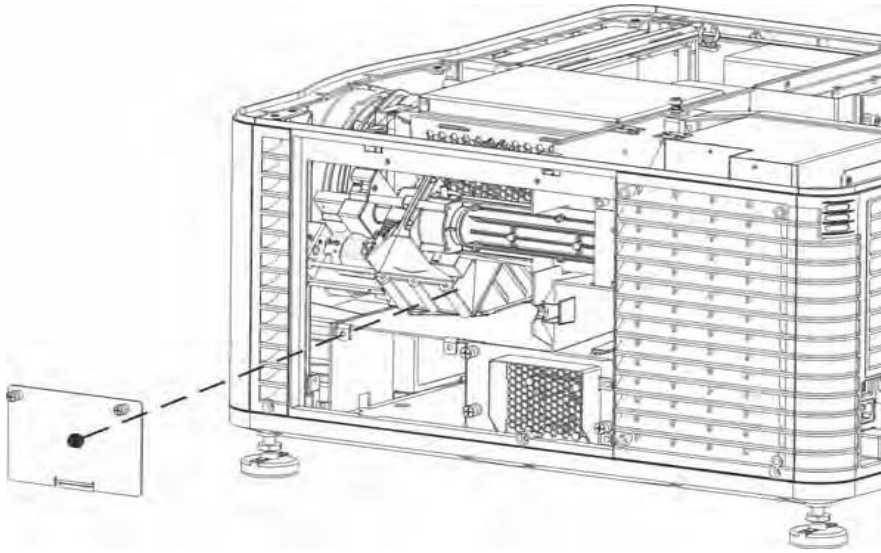

6. Slide the air filter out and inspect it.
 - If the filter appears dirty and you cannot see through it, replace it with a new paper filter, or clean it if it is a washable filter.
 - If the filter appears clean, continue to step 7.
7. Replace the air filter with the airflow indicator facing toward the projector.
8. Install the cap plate and tighten the two captive screws.
9. Install the service panel and then tighten the two screws.
10. Install the top lid.

Cleaning a washable filter

If the amount of dirt on the filter is minimal, use a vacuum or compressed air to remove it. If you use compressed air, the air must move through the filter in the opposite direction of the air flow indicator on the side of the filter.



Caution! If not avoided, the following could result in minor or moderate injury.

- Install dry filters only. Wet or damp filters can cause an electrical short and damage the product.

1. Hold the filter on an angle under warm running water so the water flows through the filter in the opposite direction of the air flow indicator on the side of the filter.
2. Rinse the filter thoroughly.
3. Submerge the filter for a minimum of 30 minutes in a container of warm water and two tablespoons of mild detergent or liquid dish soap.
4. If the filter is extremely dirty, move the filter from side-to-side occasionally or remove the excess dirt by brushing both sides of the filter with a soft brush.
5. Rinse the filter thoroughly by holding it on an angle under cool running water.
 - The air flow arrow on the side of the filter should face down.
6. If the filter still appears dirty, repeat steps 3 and 4.

7. Shake the filter over a container until most of the water is removed.
8. Place the filter on its edge on a flat, stable surface and allow it to dry thoroughly.
9. To confirm that the filter is dry, place it over a dry paper towel and shake it. If the paper towel remains dry, the filter can be installed in the projector.
10. Record the date the filter was cleaned.
11. Replace the filter following the instructions for the specific filter.

Replacing the lens

The lens seals the projection head, preventing contaminants from entering the main electronics area. Do not operate the projector without a lens installed. Install a lens plug when you install or transport the projector.

1. On the touch panel Main screen, tap and hold the power button to turn off the and projector.
2. Allow the to cool for a minimum of 15 minutes.
3. Disconnect the projector from AC power or turn the circuit breaker off.
4. Install the lens cap and turn the lens clamp to the open position.
5. If necessary, remove the two cap screws securing the lens to the lens mount using a hex key.
6. Pull the lens out of the lens mount and then install a small lens cap on the rear of the lens.
7. Remove the small rear cap from the new lens.
Keep the front cap on.
8. Align the tabs on the lens plate with the lens mount.
9. Insert the lens until it connects with the magnets on the mount.
When the lens contacts the magnetic plates it is seated correctly.
10. Secure the lens clamp by rotating it clockwise.
11. Tighten the lens mount cap screws for added stability.
12. Remove the lens cap from the front of the lens.

Troubleshooting

The following topics cover common projector issues and their solutions. If an issue cannot be resolved, contact a Christie qualified technician.

Projector functionality

The following topics cover common projector issues and their solutions.

Projector does not turn on

When I attempt to power on the projector, it does not turn on.

Resolution

- Verify the power cord is connected to the projector and the AC power supply correctly and the input selector switch is in the correct position.
- Verify the wall circuit breaker is on. If there is a problem with the wall circuit breaker turning off, contact a certified electrician.
- On the F-MAIN faceplate, verify the POWER LED is lit. When the harnessing, supply, and HUB boards are healthy, the POWER LED is either green or red in all powered states. A green LED indicates that the supply is healthy. A red LED indicates a failed power supply.
- If the POWER LED is green and additional LEDs are lit on the F-MAIN faceplate, record the color combination of the faceplate LEDs after they have been powered for at least 30 seconds. You can then provide the color combination information to Christie technical support.
- If the POWER, INPUT, HUB, and SMS LEDs are all green, but the touch panel still does not turn on or display an image, eliminate the cable and touch screen by connecting any external VGA display.

Cannot establish communication with projector

The input devices cannot communicate with the projector.

Resolution

- Verify all input devices have the same subnet mask and gateway, and unique IP addresses.

Display issues

The following topics cover common display issues and their solutions.

Flicker, shadows, or dimness

The projector image flickers, contains shadows, or dim.

Resolution

- Verify that the douser is open.
- A fold mirror or integrator rod misalignment could exist. Contact your Christie qualified service technician to resolve the issue.

Blank screen with no display of cinema image

When the projector is turned on, nothing is displayed.

Resolution

- Ensure the lens cap is not on either end of the lens.
- Ensure the light module is on.
- Confirm all power connections are still good.
- Ensure the douser is open by verifying the state of the douser on Main panel.
- Ensure any test pattern other than the full black test pattern displays properly.
- Verify the correct display file is selected.
- For cinema connections, verify the correct port is selected.

Severe motion artifacts

The displayed image has artifacts such as smearing and double image perception.

Resolution

- Verify if there is a synchronization problem with reversed 3-2 pull-down in the 60Hz-to-24Hz film-to-digital conversion and correct it at the source.

Image is vertically stretched or squeezed

The image appears vertically stretched or squeezed into the center of the screen.

Resolution

- In the left navigation menu, tap Image Settings > Source File Setup and verify the resolution and aspect ratio settings.
- In the left navigation menu, tap Image Settings > Screen File Setup and verify the lens factor settings.

Inaccurate display colors

The colors in the image are not what I expected to see.

Resolution

1. In the left navigation menu, tap Channel Setup.

2. In the left pane, select a channel.
3. In the PCF list, verify that the correct value is selected
4. In the Color Space field, verify that correct value is selected.

Accessing laser system diagnostics

An additional control panel is provided for fine adjustment of laser module. But it is not necessary for normal operation. You can find the information of this LMCP (Laser Module Control Panel) in appendix.

Assembling the touch panel.

Assemble a touch panel to diagnose errors of laser module and cooling system.

1. Connect the LMCP before turning on the project
2. For the User account, use the password 8888.
3. Errors code list in the Appendix.

Regulatory

This product conforms to the latest regulations and standards related to product safety, environmental, and electromagnetic compatibility (EMC) requirements.

Safety

- ANSI/UL 60950-1 – Information Technology Equipment – Safety – Part 1: General Requirements
- ANSI/UL 62368-1 - Audio/video, information and communication technology equipment – Part 1: Safety requirements
- CAN/CSA C22.2 No. 60950-1-07 – Information Technology Equipment – Safety – Part 1: General Requirements
- IEC/EN 60825-1:2014 – Safety of Laser Products – Part 1: Equipment Classification and Requirements
- IEC/EN 60950-1 – Information Technology Equipment – Safety – Part 1: General Requirements
- IEC/EN62368-1 – Audio/video, information and communication technology equipment – Part 1: Safety requirements
- IEC/EN 62471-5:2015 – Photobiological Safety of Lamps and Lamp Systems – Part 5: Image projectors

Electro-magnetic compatibility

Emissions

- CAN ICES-003 (A)/NMB-003 (A) – Information Technology Equipment (Including Digital Apparatus) – Limits and Methods of Measurement
- CISPR 32:2015/EN 55032:2015, Class A – Electromagnetic Compatibility of Multimedia Equipment – Emission Requirements
- FCC CFR47, Part 15, Subpart B, Class A – Unintentional Radiators
- IEC 61000-3-2/EN61000-3-2: Limits for harmonic current emissions for equipment with input current ≤ 16 A
- IEC 61000-3-3/EN61000-3-3: Limitations of Voltage Changes, Voltage Fluctuations, and Flicker input current ≤ 16 A

Immunity

- CISPR 35:2016/EN 55035:2017 Electromagnetic compatibility of multimedia equipment - Immunity requirements

Environmental

- China Ministry of Information Industry (along with 7 other Government Agencies) Order No.32 (01/2016) on the control of pollution caused by electronic information products, hazardous substances concentration limits (GB/T 26572 - 2011), and the applicable product marking requirement (SJ/T 11364 - 2014).
- EU Directive (2011/65/EU) on the restriction of the uses of certain hazardous substances (RoHS) in electrical and electronic equipment and the applicable official amendment(s).
- EU Directive (2012/19/EU) on waste and electrical and electronic equipment (WEEE) and the applicable official amendment(s).
- Regulation (EC) No. 1907/2006 on the registration, evaluation, authorization and restriction of chemicals (REACH) and the applicable official amendment(s).

International packaging recycling mark requirements.

- EU Directive (94/62/EC) on packaging and packaging waste
- China packaging recycling mark standard (GB18455-2001)
- EU Directive (2012/19/EU) on waste and electrical and electronic equipment (WEEE) and the applicable official amendment(s).

Appendix

#	Code	Error Message	Description
1	1000	Chiller	1000: Communication error of Chiller
2	2000	Switching Power Supply	2000: Switching power failure
3	3000	Motor	3000: Motor fault
4	4000	Ambient temperature	4001: Ambient temperature too high
			4002: Ambient temperature too low
			4003: Loss of ambient temperature data
5	5000	Ambient humidity	5001: Ambient humidity too high
			5003: Loss of ambient humidity data
6	7000	Real-time clock	7001: loss of Real-time clock data
			7002: Real-time clock data error
			7003: Need to replace the battery
7	8000	Fan speed	8000+No: Fan.No speed error
8	9000	Laser	9001: laser speed error
			9002: Fan of Laser speed error
			9003: loss of laser Temperature data
			9004: laser Temperature too high
9	10000	PUMP	10001: PUMP stop
10	11000	Remaining time	11000: The remaining time is too low
			11001: The remaining time is 0 hour
			11002: The remaining time error
11	12000	Laser output level	Laser output level error: 12000+Reduced gear
12	13000	Temperature of laser	13000 + Number of temperature alarm
13	14000	Current of laser	14000 + Number of current alarm

