

Assembling the Boxer rigging frame

The rigging frame is designed for use with the Boxer series of projectors. Using the frame, the projector or projectors can be secured to trusses or structures built for the purpose of positioning the projector.

Allowable rigging configurations are:

- Single projector in landscape orientation
- Two or three projectors stacked in landscape orientation
- Single projector in portrait orientation
Portrait orientation refers to a 90 degrees rotation about the lens axis resulting in the side panel display facing up.
- Lens pointing straight down, single projector

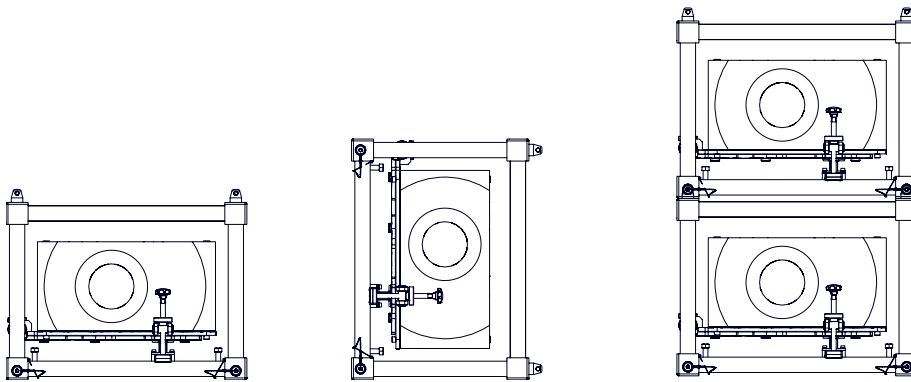

Safety warnings and guidelines

All safety warnings and guidelines should be read before starting the procedure.



Danger! Failure to comply with the following results in death or serious injury.

- Do not stack more than three projectors in landscape orientation.



Warning! Failure to comply with the following could result in death or serious injury.

- Only use this frame with the specified products.
- Do not use the frame to mount the projector in an inverted configuration.
- The maximum tilt allowed for a stack of framed projectors is +/- 10 degrees when suspended from a truss.
- The maximum tilt allowed for framed projectors stacked on a floor is +/- 5 degrees.
- Always install safety straps when the frame and projector are installed overhead.



Notice. Failure to comply with the following may result in property damage.

- Use appropriate packaging when shipping the product installed in the frame.

Tools required

The following tools are required for assembling the rigging frame.

- M10 hex key

Preparing the projector

Remove the projector feet prior to installing it into the rigging frame.

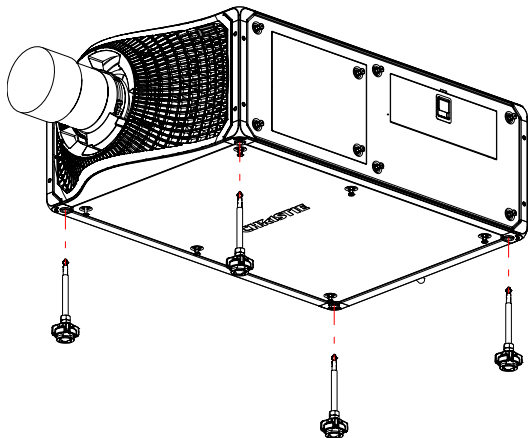

1. Ensure the projector is in a secure position.

You can set the projector on a table in portrait orientation with the user interface facing up. Christie does not recommend having the projector overhang when removing the feet, unless the projector is securely positioned.

2. Loosen the lock nuts on the feet.
3. Uninstall the feet.

Installing the projector to the frame base

Make sure the projector is secured to the rigging frame prior to installing to a truss or for stacked configurations.

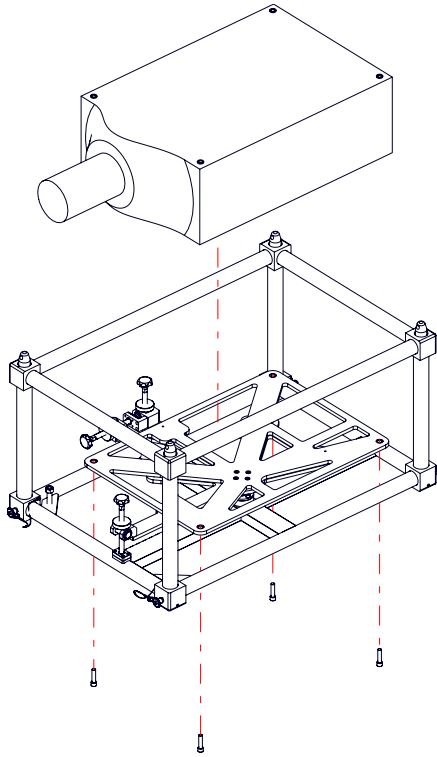

1. Lift the projector onto the adjuster plate.

The projector weight is 160 lbs (73 kg). Consult local health and safety regulations for the guidelines on the number of people required to lift the projector. Christie recommends a minimum of four people to lift the projector.

Care must be taken to avoid finger pinching during the handling and placing of the unit on the frame adjuster plate.

Use an additional person as a spotter to guide the projector into the locating features on the adjuster plate. The spotter must instruct the lifters to place the unit down on the adjuster so that the locating features in the projector's base plate align over the mounting holes.

2. Secure the projector to the adjuster with the washers and fasteners supplied with the frame.
3. Tighten the fasteners to a torque of 34 Nm.

Rigging the projector

If securing the frame to a truss or similar structure, a minimum of four clamps (two clamps along opposite members of the frame) or four straps/cables must be used in both landscape and portrait orientation.

1. Ensure the clamps or straps/cabling are adequately rated to support the total weight of the load and are placed on either side of the assembly.

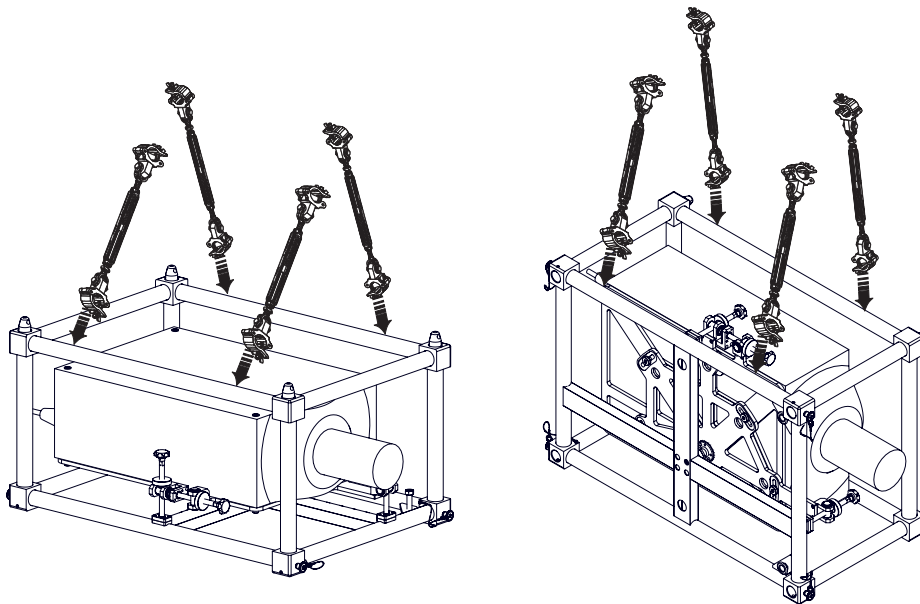

- When stacking two or three framed projectors ensure the locking pins are fully engaged and the safety straps are installed between the frames.
Safety straps (not included) must be adequately rated for the total load.
- Use the setscrews located in each stacking block to help reduce free play in a stacking configuration.

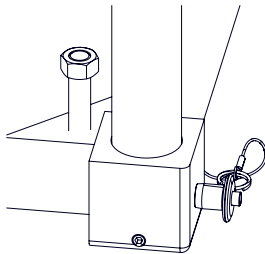

- Refer to the Boxer mechanical drawing for the center of gravity of the projector and the projector installed in the frame.

Adjusting the projector

Use the Boxer rigging frame to adjust the orientation of the projector. Stacked projectors can be adjusted independently.

The rigging frame allows the orientation of the projector to be adjusted with respect to what it is secured to and allows for independent adjustment of connected projectors. The maximum adjustment in any direction (pitch, yaw, or roll) at a time is 5 degrees

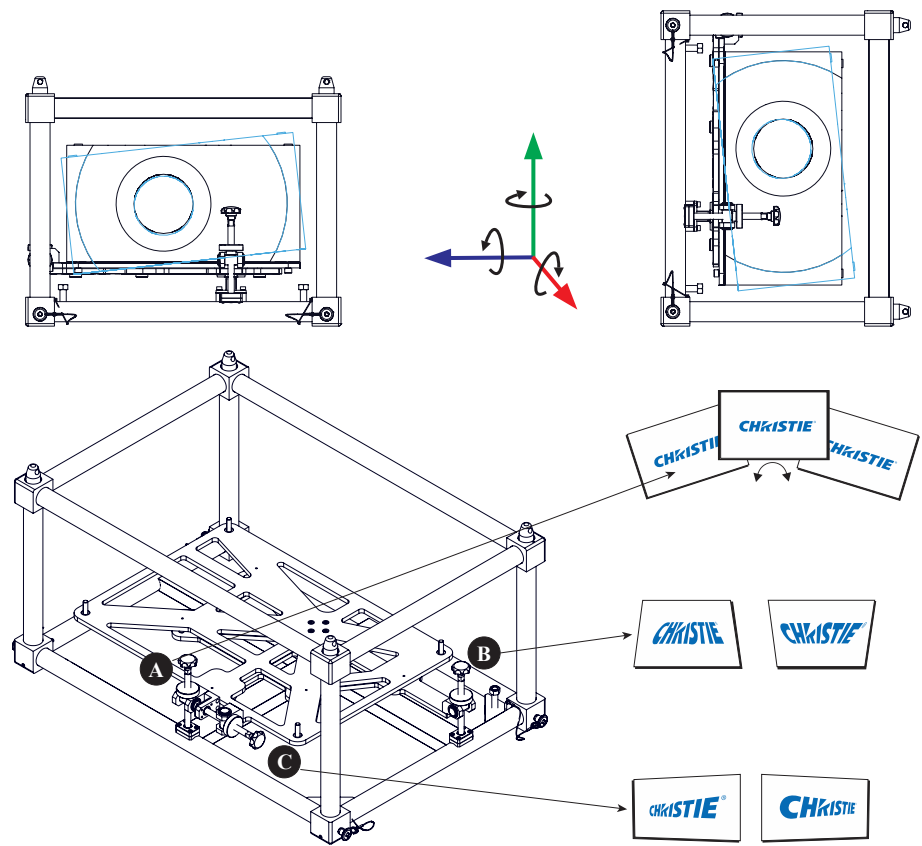

1. To roll or tilt the image left or right, adjust the A knob.
2. To pitch the image up or down (vertical keystone), adjust the B knob.
3. To yaw the image left or right (horizontal keystone), adjust the C knob.